

# Tarjetas de rescate

FORD SERVICE

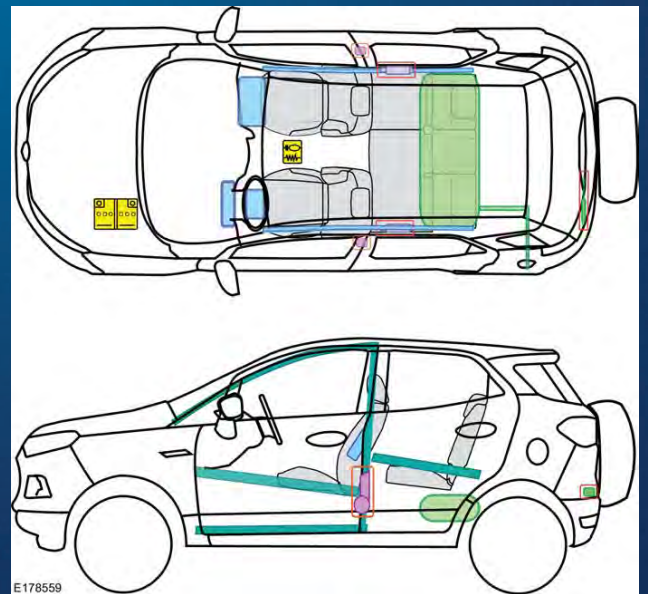
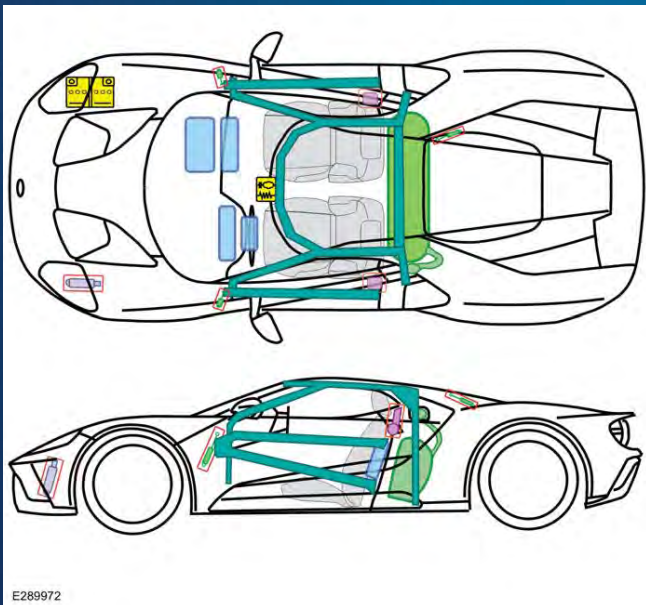
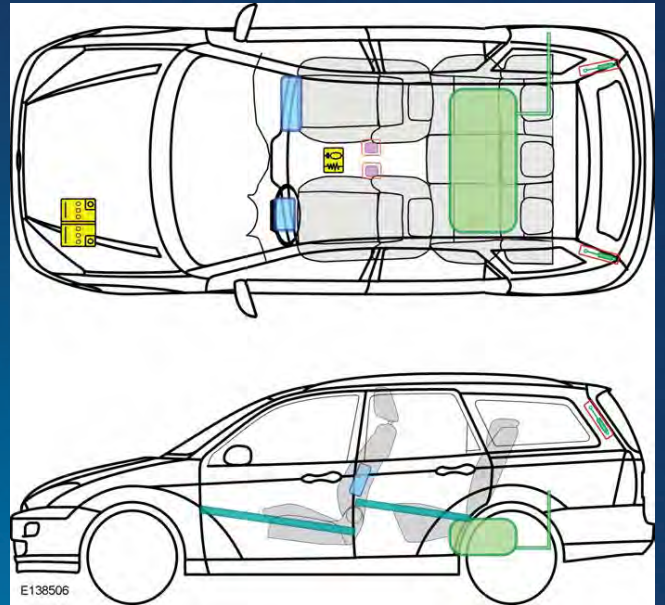
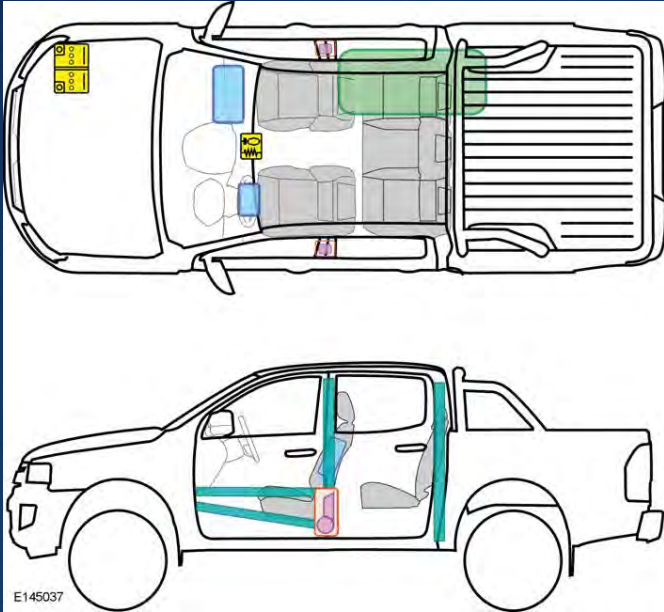

### **Aviso legal**

Estas tarjetas de rescate se han desarrollado para ayudar de forma adecuada al personal cualificado de los servicios de emergencia que atiende los accidentes de tráfico en los que estén implicados vehículos Ford vendidos en la Unión Europea.

La información que incluye esta publicación era correcta en el momento de enviarse a imprenta.

Como parte de la política de continua mejora, nos reservamos el derecho de cambiar especificaciones, diseño o equipo en cualquier momento sin previo aviso y sin incurrir en ninguna obligación.

Se exceptúan errores y omisiones.

Todos los derechos reservados.

(Fecha De Publicacion: : 05/2021)



# FORD SERVICE

## Tarjetas de rescate

Modelo	Fecha de fabricación
<b>B</b>	
B-MAX	08/2012 – >
B-MAX - LPG	03/2013 – >
<b>C</b>	
C-MAX	06/2003 – 10/2007
C-MAX	10/2007 – 12/2010
C-MAX	11/2010 – 03/2015
C-MAX - LPG	06/2003 – 10/2007
C-MAX - LPG	10/2007 – 12/2010
C-MAX - CNG	06/2003 – 10/2007
C-MAX - CNG	10/2007 – 12/2010
C-MAX (Compact MAV (5 plazas))	03/2015 – >
C-MAX - LPG (Compact MAV (5 plazas))	06/2012 – 03/2015
C-MAX - LPG (Compact MAV (5 plazas))	03/2015 – >
C-MAX (Grand MAV (5+2 plazas))	11/2010 – 03/2015
C-MAX (Grand MAV (5+2 plazas))	03/2015 – >
C-MAX E=NERGI - HEV	10/2014 – >
<b>E</b>	
Eco Sport	09/2013 – >
Edge	06/2018 – >
Edge (SUV 5 puertas)	10/2015 – 06/2018
Explorer PHEV - HEV	
<b>F</b>	
Fiesta	01/1996 – 02/2000
Fiesta	02/2000 – 02/2002
Fiesta (3 puertas)	06/2008 – 04/2017
Fiesta (3 puertas)	11/2001 – 09/2008
Fiesta (3 puertas)	04/2017 – >
Fiesta - LPG (3 puertas)	06/2008 – 04/2017
Fiesta (5 puertas)	11/2001 – 09/2008
Fiesta (5 puertas)	06/2008 – 04/2017
Fiesta (5 puertas)	04/2017 – >
Fiesta - LPG (5 puertas)	06/2008 – 04/2017
Fiesta mHEV (1,0l EcoBoost (92kW/125CV) (B7), 1,0l EcoBoost (114kW/155CV) (BZ), 3 puertas)	04/2017 – >

Modelo	Fecha de fabricación
Fiesta mHEV (1,0l EcoBoost (92kW/125CV) (B7), 1,0l EcoBoost (114kW/155CV) (BZ), 5 puertas)	04/2017 – >
Focus (3 puertas)	07/2004 – 08/2007
Focus (3 puertas)	08/2007 – 03/2011
Focus (3 puertas)	08/1998 – 12/2004
Focus - LPG (3 puertas)	08/2007 – 03/2011
Focus - LPG (3 puertas)	07/2004 – 08/2007
Focus - CNG (3 puertas)	07/2004 – 08/2007
Focus - CNG (3 puertas)	08/2007 – 03/2011
Focus (4 puertas)	07/2004 – 08/2007
Focus (4 puertas)	08/1998 – 12/2004
Focus (4 puertas)	08/2007 – 03/2011
Focus (4 puertas)	03/2011 – 09/2014
Focus (4 puertas)	09/2014 – 04/2018
Focus (4 puertas)	04/2018 – >
Focus (5 puertas)	08/2007 – 03/2011
Focus (5 puertas)	08/1998 – 12/2004
Focus (5 puertas)	03/2011 – 09/2014
Focus (5 puertas)	07/2004 – 08/2007
Focus (5 puertas)	09/2014 – 04/2018
Focus (5 puertas)	04/2018 – >
Focus - LPG (5 puertas)	08/2007 – 03/2011
Focus - LPG (5 puertas)	07/2004 – 08/2007
Focus - LPG (5 puertas)	05/2012 – 09/2014
Focus - LPG (5 puertas)	09/2014 – 04/2018
Focus - CNG (5 puertas)	08/2007 – 03/2011
Focus - CNG (5 puertas)	07/2004 – 08/2007
Focus (Descapotable)	03/2007 – 07/2010



# FORD SERVICE

## Tarjetas de rescate

Modelo	Fecha de fabricación
Focus (Familiar)	07/2004 – 08/2007
Focus (Familiar)	08/2007 – 03/2011
Focus (Familiar)	08/1998 – 12/2004
Focus (Familiar)	03/2011 – 09/2014
Focus (Familiar)	09/2014 – 04/2018
Focus (Familiar)	04/2018 – >
Focus - LPG (Familiar)	08/2007 – 03/2011
Focus - LPG (Familiar)	07/2004 – 08/2007
Focus - LPG (Familiar)	05/2012 – 09/2014
Focus - LPG (Familiar)	09/2014 – 04/2018
Focus E=LECTRIC	
Focus mHEV (1,0l EcoBoost (92kW/125CV) (B7), 1,0l EcoBoost (114kW/155CV) (M0), 5 puertas)	04/2018 – >
Focus mHEV (1,0l EcoBoost (92kW/125CV) (B7), 1,0l EcoBoost (114kW/155CV) (M0), Familiar)	04/2018 – >
Fusion	06/2002 – >
<b>G</b>	
Galaxy	02/2006 – 05/2015
Galaxy	04/2000 – 02/2006
Galaxy (5 puertas LMV)	05/2015 – >
GT	12/2017 – >
<b>K</b>	
KA	08/2008 – >
KA	09/1996 – 07/2008
Ka+	05/2016 – >
Kuga	02/2008 – 10/2012
Kuga	10/2012 – >
Kuga	07/2019 – >
Kuga mHEV	06/2019 – >
Kuga PHEV (2,5l Duratec – Híbrido (121 kW/164CV) (BG))	06/2019 – >
<b>M</b>	
Mondeo (4 puertas)	10/2000 – 02/2007
Mondeo (4 puertas)	02/2007 – 09/2014
Mondeo - LPG (4 puertas)	02/2007 – 09/2014

Modelo	Fecha de fabricación
Mondeo (5 puertas)	10/2000 – 02/2007
Mondeo (5 puertas)	02/2007 – 09/2014
Mondeo (5 puertas)	09/2014 – >
Mondeo - LPG (5 puertas)	02/2007 – 09/2014
Mondeo (Familiar)	10/2000 – 02/2007
Mondeo (Familiar)	02/2007 – 09/2014
Mondeo (Familiar)	09/2014 – >
Mondeo - LPG (Familiar)	02/2007 – 09/2014
Mondeo "Hybrid" - HEV (4 puertas)	10/2014 – >
Mondeo "Hybrid" - HEV (Familiar)	01/2019 – >
Mustang (Coupé)	03/2015 – >
Mustang (Descapotable)	03/2015 – >
<b>P</b>	
Puma	10/2019 – >
Puma mHEV (1,0l EcoBoost (92kW/125CV) (B7), 1,0l EcoBoost (114kW/155CV) (BZ))	10/2019 – 04/2020
Puma mHEV (1,0l EcoBoost (92kW/125CV) (B7), 1,0l EcoBoost (114kW/155CV) (BZ))	04/2020 – >
<b>R</b>	
Ranger	06/2006 – 07/2011
Ranger	07/2011 – >
<b>S</b>	
S-MAX	02/2006 – 05/2015
S-MAX (5 puertas SAV)	05/2015 – >
Streetka (Descapotable)	01/2003 – 07/2005
<b>T</b>	
Tourneo Connect	09/2013 – >
Tourneo Connect	06/2002 – 07/2013
Tourneo Courier	03/2014 – >
Tourneo Custom	07/2012 – >
Tourneo Custom mHEV	04/2019 – >
Transit 2014.5 (Autobús M2)	08/2013 – >
Transit 2014.5 (Chasis cabina)	08/2013 – >
Transit 2014.5 (Chasis cabina doble)	08/2013 – >



# FORD SERVICE

Tarjetas de rescate

Modelo	Fecha de fabricación
Transit 2014.5 (Furgoneta)	08/2013 – >
Transit 2014.5 (Kombi NI)	08/2013 – >
Transit Connect (Furgoneta de batalla larga)	02/2013 – >
Transit Courier	
Transit Custom	07/2012 – >
Transit Custom mHEV	04/2019 – >
Transit Custom PHEV - HEV (1,0l EcoBoost (90kW/120CV))	09/2019 – >
Transit Tourneo	08/2007 – >

(Fecha De Publicacion: : 05/2021)



# FORD SERVICE

Tarjetas de rescate

## FORD B-MAX

08/2012 – >



E157559

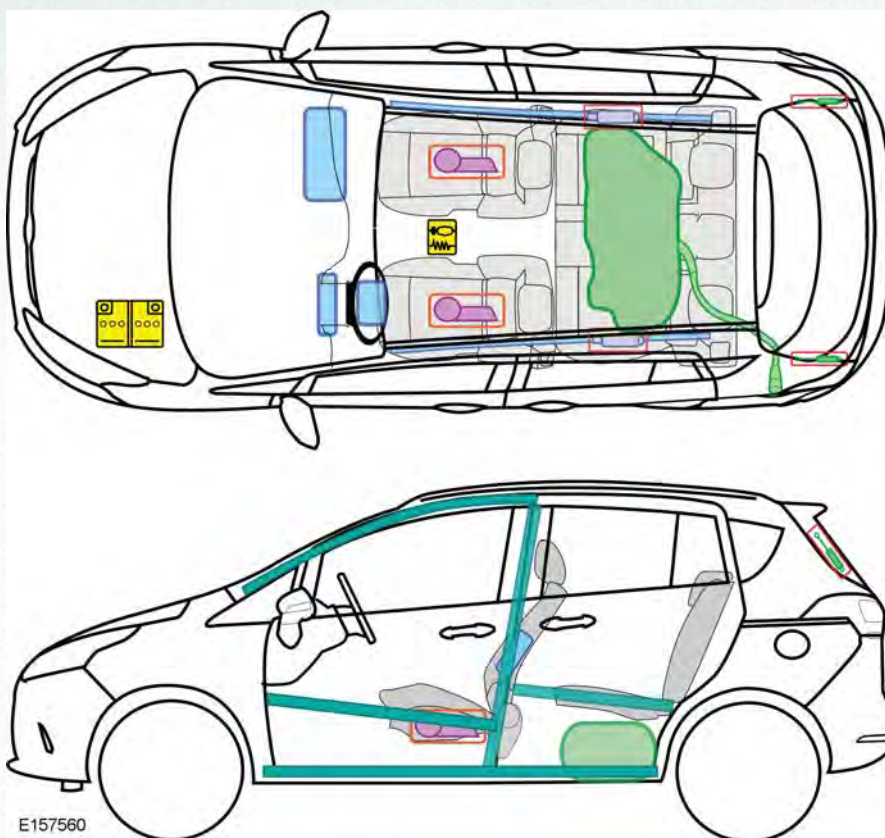

E157560

### Epígrafe

**B**

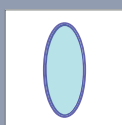

Airbag

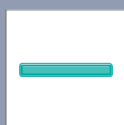

Refuerzos estructurales



Unidad de control



Sistema de protección de los peatones



Generador de gas



Protección antivuelco activa

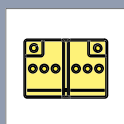

Batería

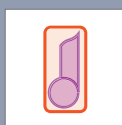

Tensor del cinturón de seguridad

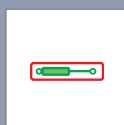

Dispositivo llenado de gas



Depósito de combustible

(Fecha De Publicacion: : 10/2012)



# FORD SERVICE

Tarjetas de rescate

## FORD B-MAX - LPG

03/2013 - >

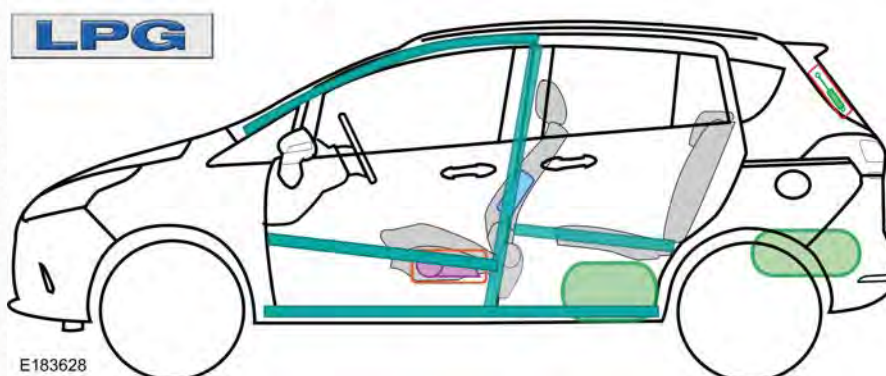
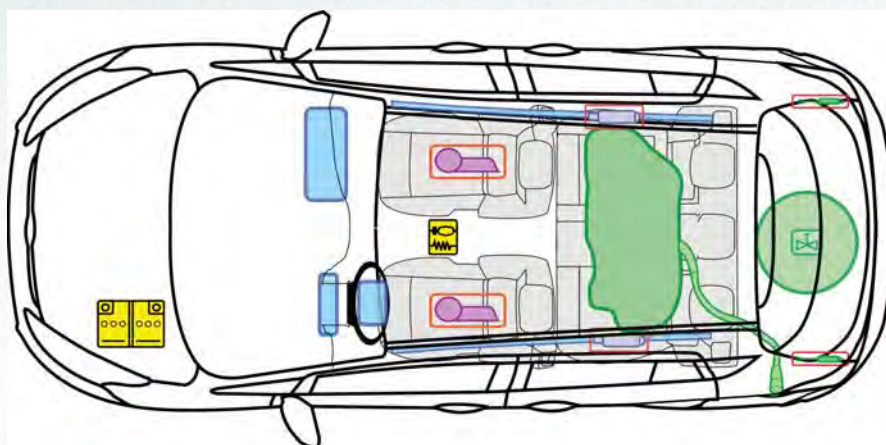

E183628

Epígrafe					B		
	Airbag		Refuerzos estructurales		Unidad de control		Sistema de protección de los peatones
	Generador de gas		Protección antivuelco activa		Batería		Depósito de gas
	Tensor del cinturón de seguridad		Dispositivo llenado de gas		Depósito de combustible		Válvula de seguridad

(Fecha De Publicacion: : 04/2014)



# FORD SERVICE

Tarjetas de rescate

## FORD C-MAX

06/2003 – 10/2007

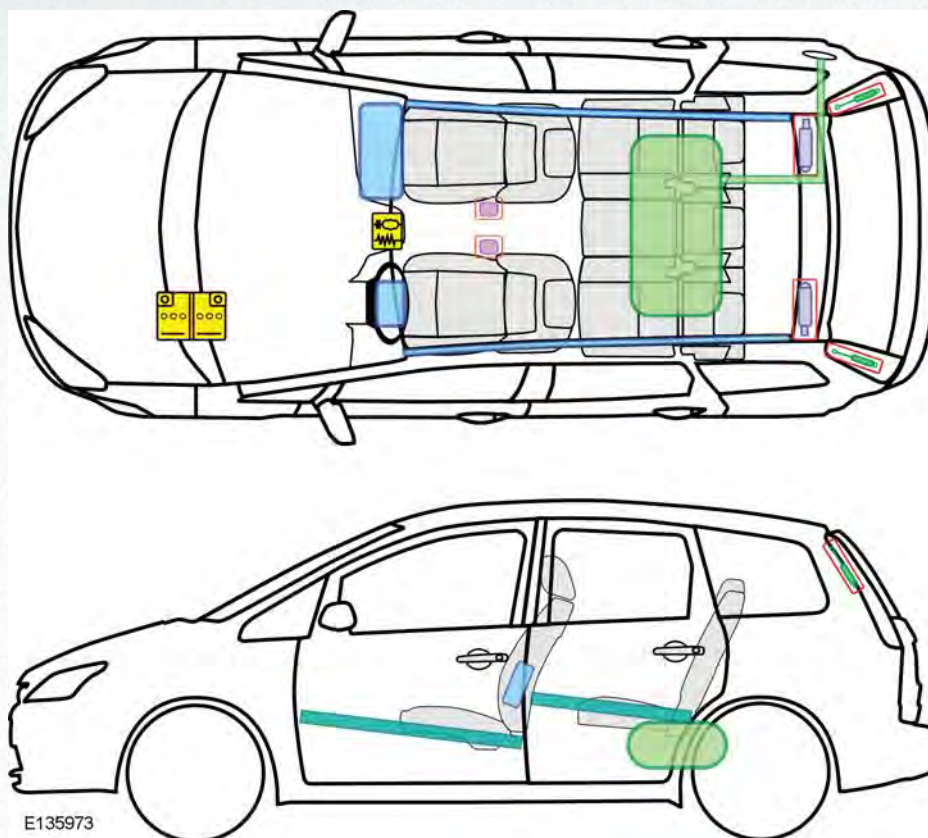

### Epígrafe

C

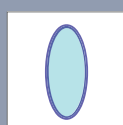

Airbag



Refuerzos estructurales



Unidad de control



Sistema de protección de los peatones



Generador de gas



Protección antivuelco activa

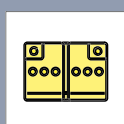

Batería

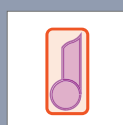

Tensor del cinturón de seguridad

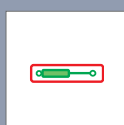

Dispositivo llenado de gas



Depósito de combustible

(Fecha De Publicacion: : 03/2011)





# FORD SERVICE

Tarjetas de rescate

## FORD C-MAX

10/2007 – 12/2010

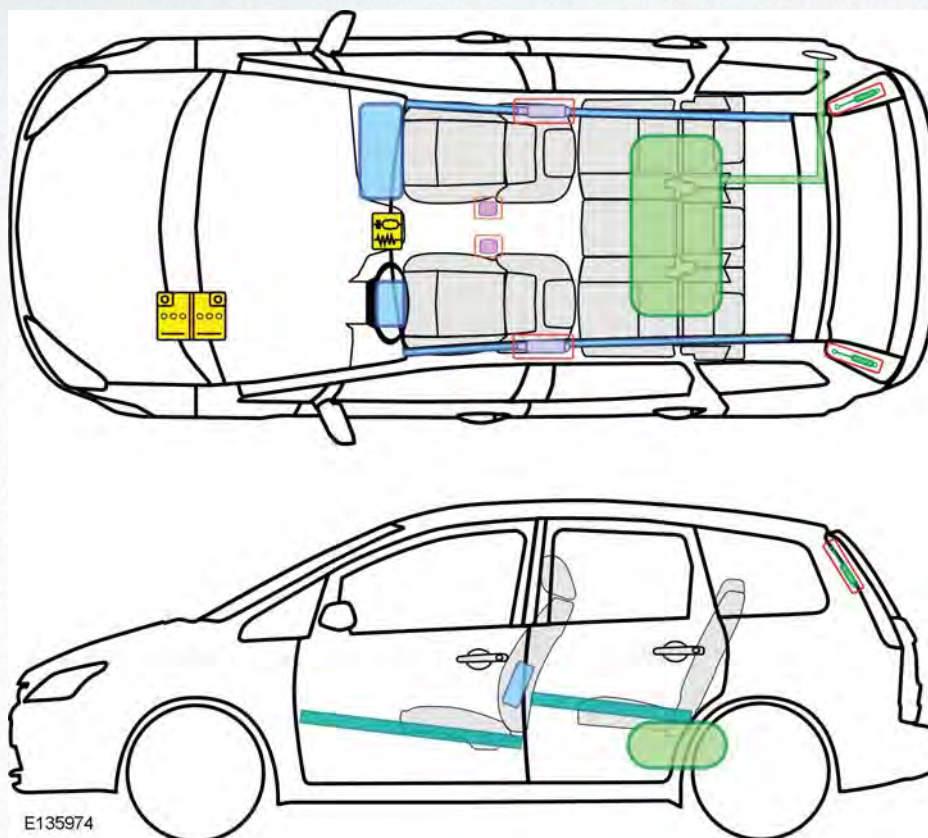

E135974

### Epígrafe

C

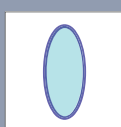

Airbag

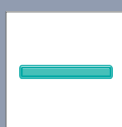

Refuerzos estructurales



Unidad de control



Sistema de protección de los peatones



Generador de gas



Protección antivuelco activa

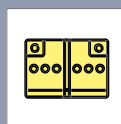

Batería

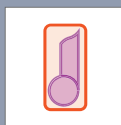

Tensor del cinturón de seguridad

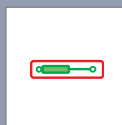

Dispositivo llenado de gas



Depósito de combustible

(Fecha De Publicacion: : 03/2011)



# FORD SERVICE

Tarjetas de rescate

## FORD C-MAX

11/2010 – 03/2015

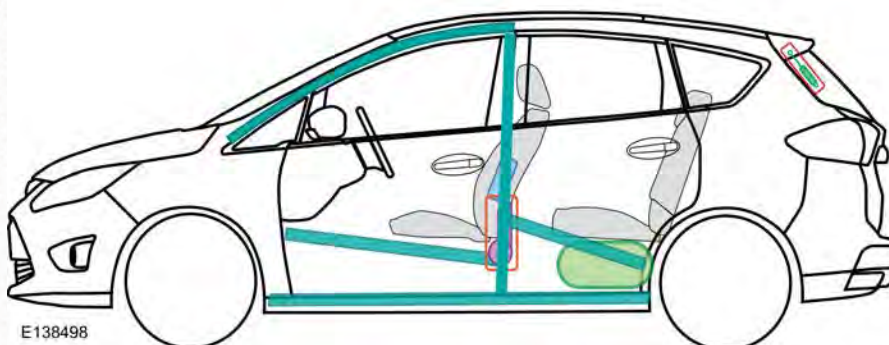
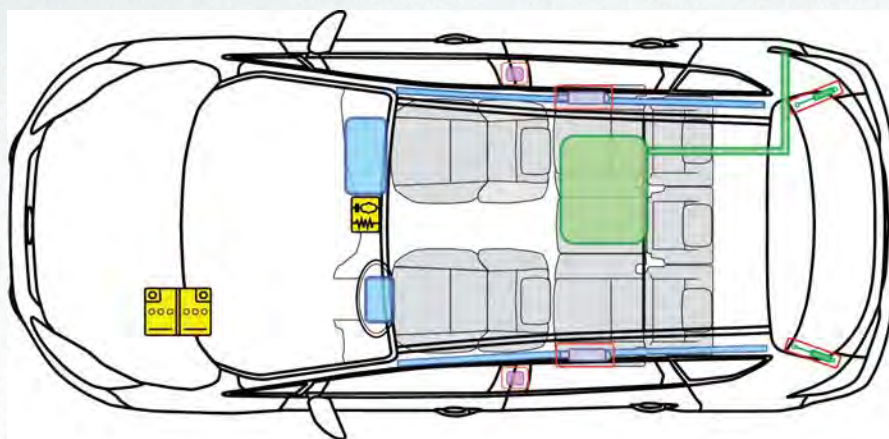

E138498

### Epígrafe

C

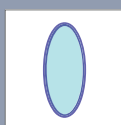

Airbag

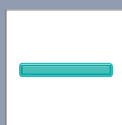

Refuerzos estructurales



Unidad de control



Sistema de protección de los peatones



Generador de gas



Protección antivuelco activa

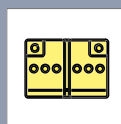

Batería

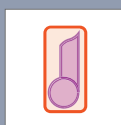

Tensor del cinturón de seguridad

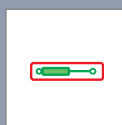

Dispositivo llenado de gas



Depósito de combustible

(Fecha De Publicacion: : 10/2012)



# FORD SERVICE

Tarjetas de rescate

## FORD C-MAX - LPG

06/2003 – 10/2007

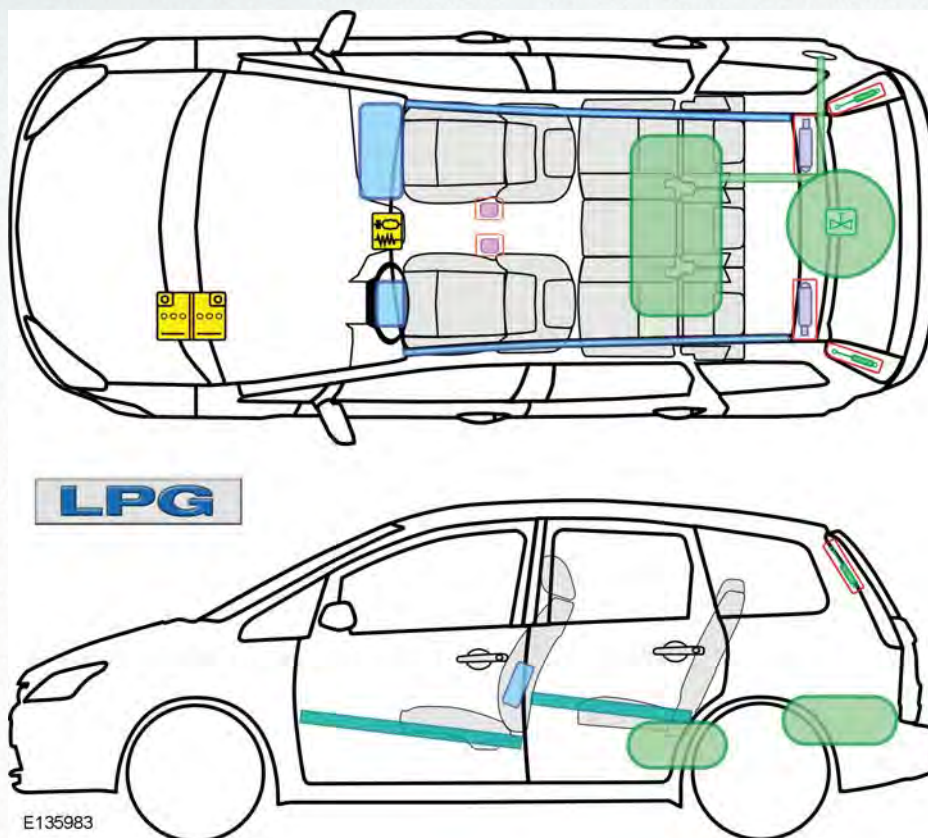

Epígrafe

C

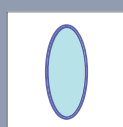

Airbag

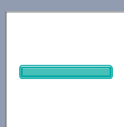

Refuerzos estructurales



Unidad de control



Sistema de protección de los peatones



Generador de gas



Protección antivuelco activa

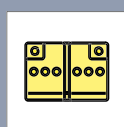

Batería



Depósito de gas

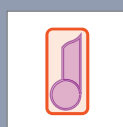

Tensor del cinturón de seguridad

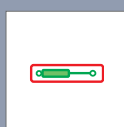

Dispositivo llenado de gas



Depósito de combustible



Válvula de seguridad

(Fecha De Publicacion: : 08/2013)



# FORD SERVICE

Tarjetas de rescate

## FORD C-MAX - LPG

10/2007 – 12/2010

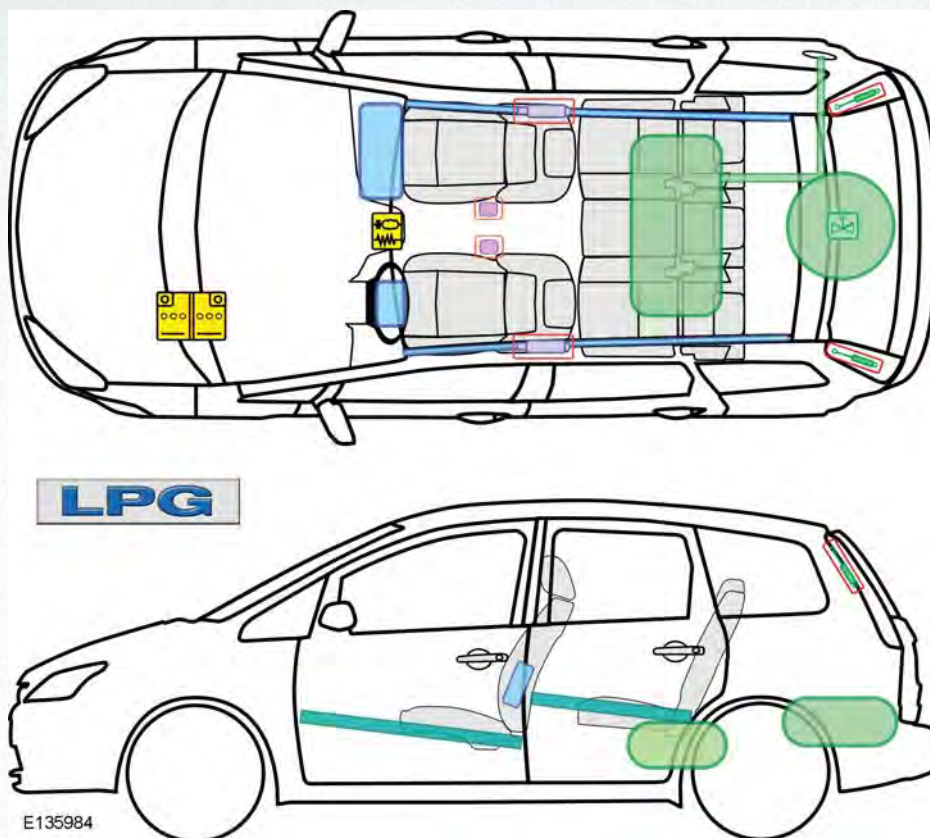

Epígrafe

C

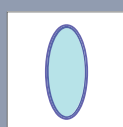

Airbag

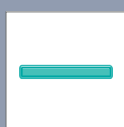

Refuerzos estructurales



Unidad de control



Sistema de protección de los peatones



Generador de gas

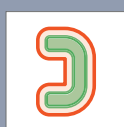

Protección antivuelco activa

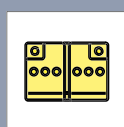

Batería



Depósito de gas

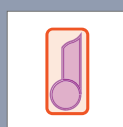

Tensor del cinturón de seguridad

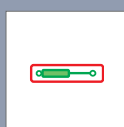

Dispositivo llenado de gas



Depósito de combustible



Válvula de seguridad

(Fecha De Publicacion: : 08/2013)



# FORD SERVICE

Tarjetas de rescate

## FORD C-MAX - CNG

06/2003 – 10/2007



E135972

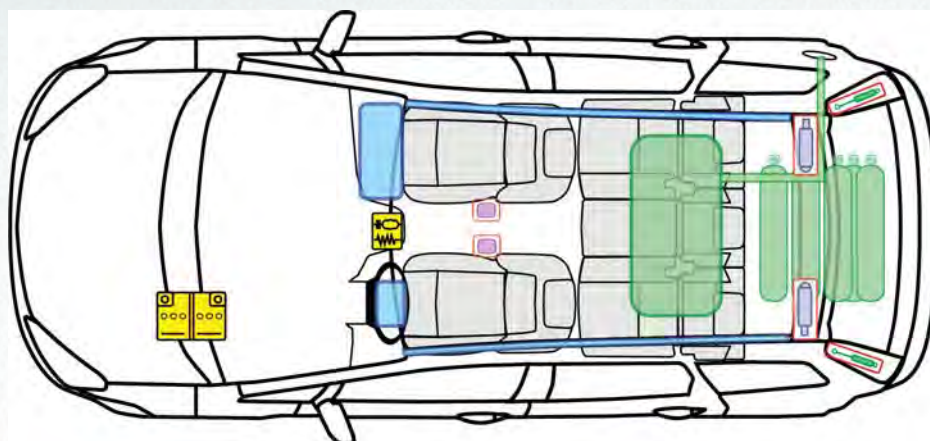



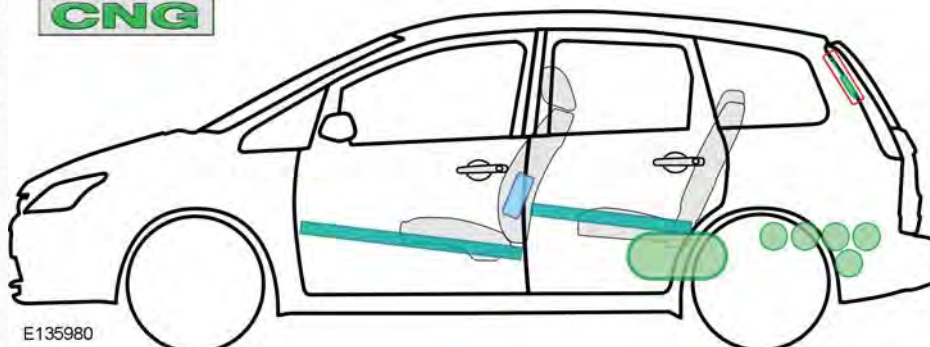









**CNG**

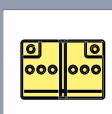

E135980

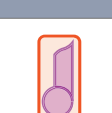
### Epígrafe

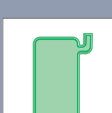
**C**

	Airbag		Refuerzos estructurales		Unidad de control		Sistema de protección de los peatones
	Generador de gas		Protección antivuelco activa		Batería		Depósito de gas
	Tensor del cinturón de seguridad		Dispositivo llenado de gas		Depósito de combustible		Válvula de seguridad

(Fecha De Publicacion: : 07/2013)



# FORD SERVICE

Tarjetas de rescate

## FORD C-MAX - CNG

10/2007 – 12/2010



E135972

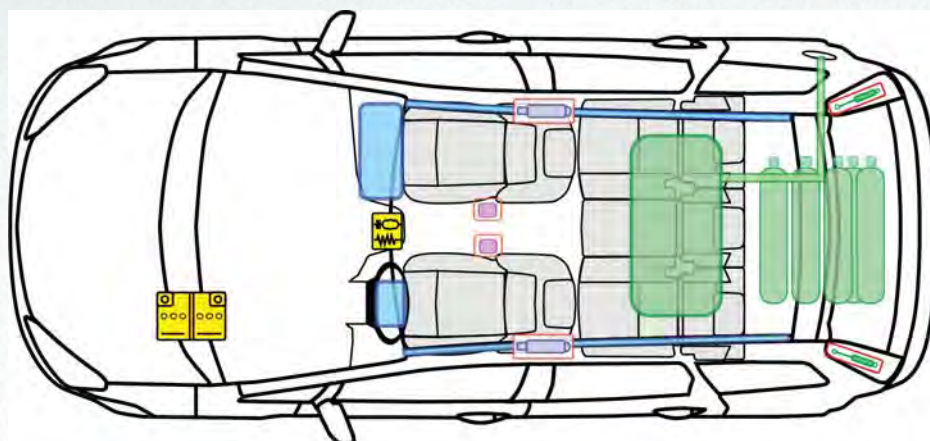



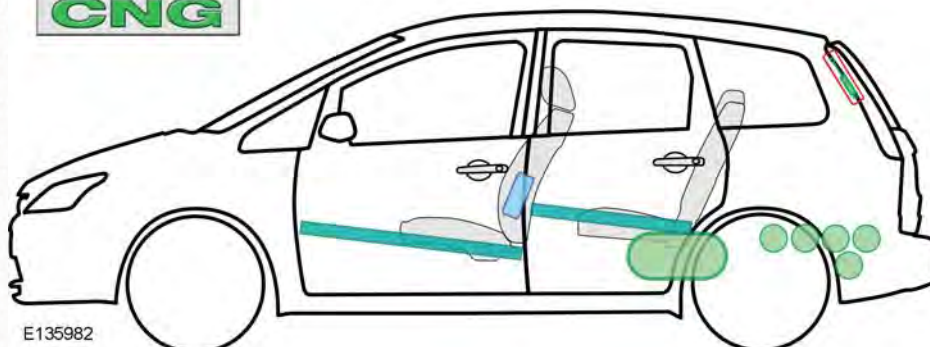









**CNG**

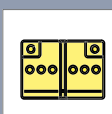

E135982

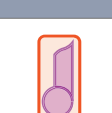
### Epígrafe

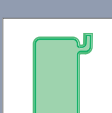
**C**

	Airbag		Refuerzos estructurales		Unidad de control		Sistema de protección de los peatones
	Generador de gas		Protección antivuelco activa		Batería		Depósito de gas
	Tensor del cinturón de seguridad		Dispositivo llenado de gas		Depósito de combustible		Válvula de seguridad

(Fecha De Publicacion: : 07/2013)



# FORD SERVICE

Tarjetas de rescate

## FORD C-MAX

Compact MAV (5 plazas)

03/2015 – >

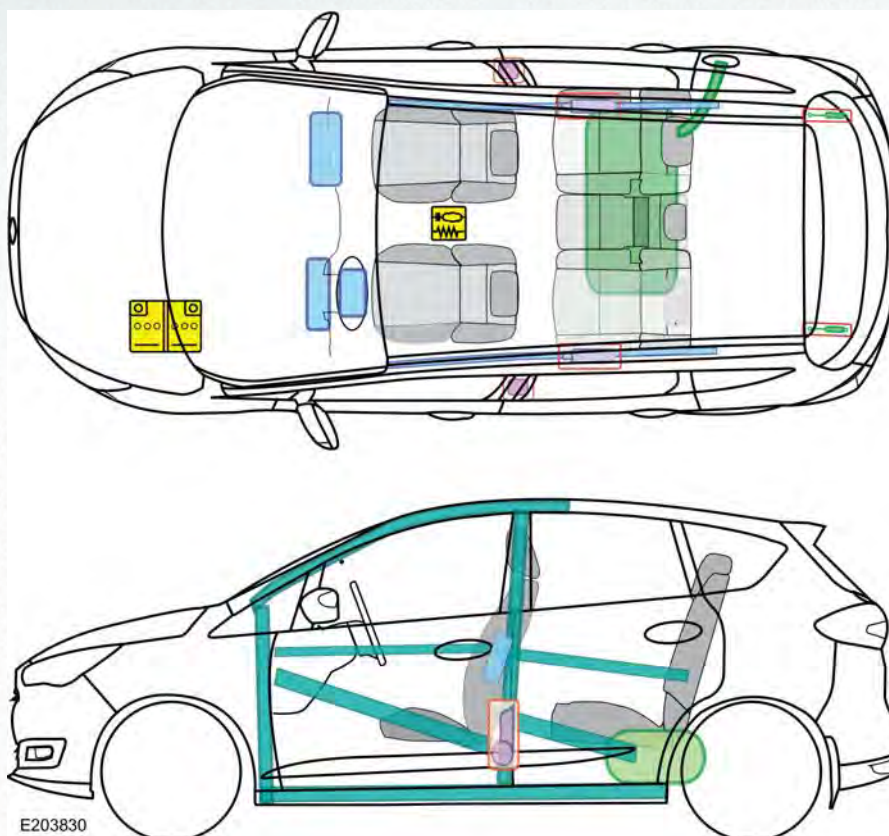

E203830

### Epígrafe

C

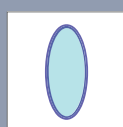

Airbag

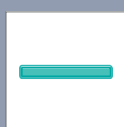

Refuerzos estructurales



Unidad de control



Sistema de protección de los peatones

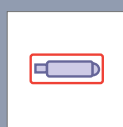

Generador de gas



Protección antivuelco activa

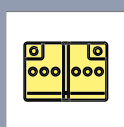

Batería

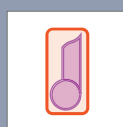

Tensor del cinturón de seguridad

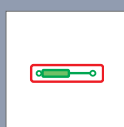

Dispositivo llenado de gas



Depósito de combustible

(Fecha De Publicacion: : 07/2015)



# FORD SERVICE

Tarjetas de rescate

## FORD C-MAX - LPG

Compact MAV (5 plazas)

06/2012 – 03/2015

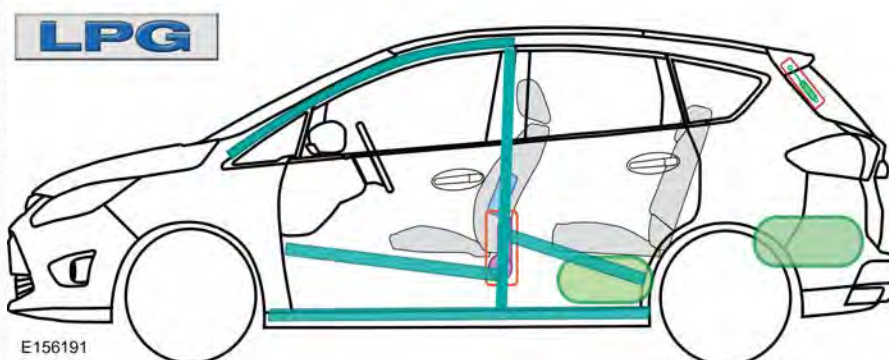
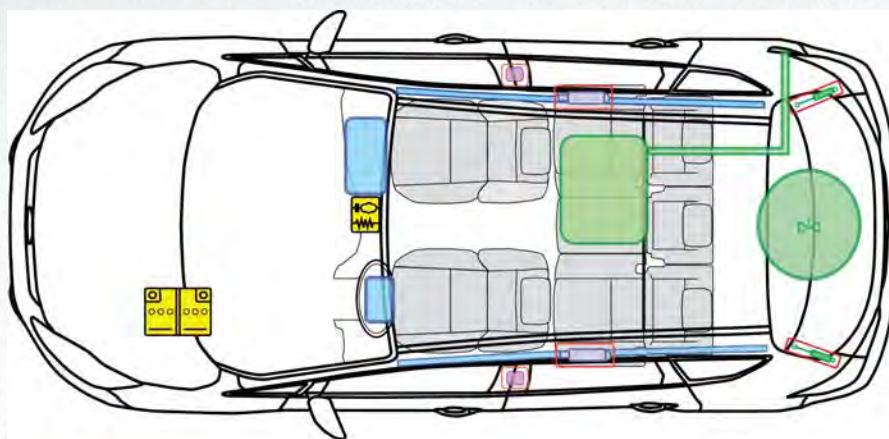

E156191

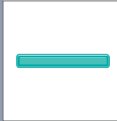
Epígrafe					C		
	Airbag		Refuerzos estructurales		Unidad de control		Sistema de protección de los peatones
	Generador de gas		Protección antivuelco activa		Batería		Depósito de gas
	Tensor del cinturón de seguridad		Dispositivo llenado de gas		Depósito de combustible		Válvula de seguridad

(Fecha De Publicacion: : 10/2012)





# FORD SERVICE

Tarjetas de rescate

## FORD C-MAX - LPG

Compact MAV (5 plazas)

03/2015 – >

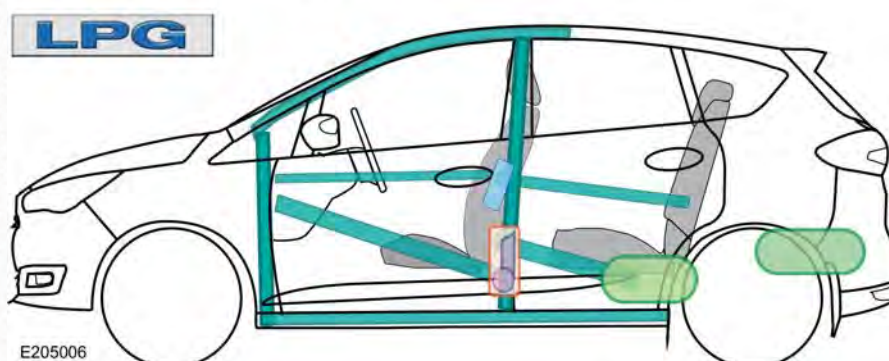
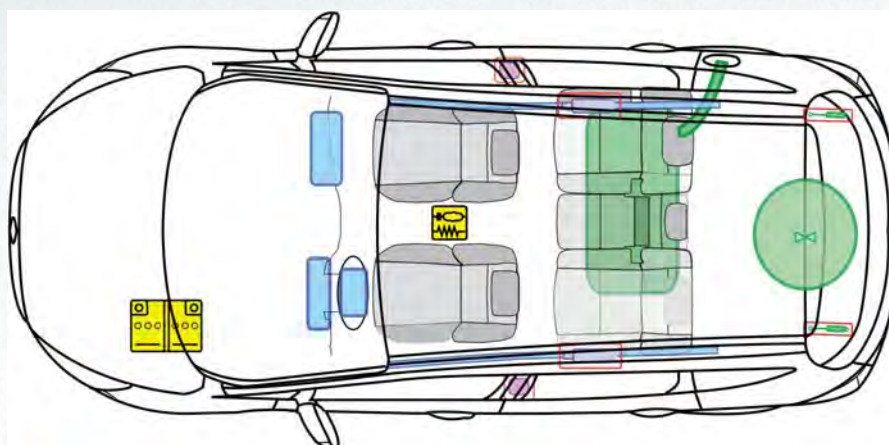

E205006

### Epígrafe

C

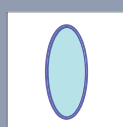

Airbag

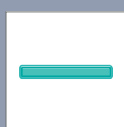

Refuerzos estructurales



Unidad de control



Sistema de protección de los peatones



Generador de gas

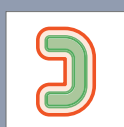

Protección antivuelco activa

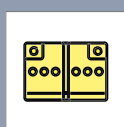

Batería



Depósito de gas

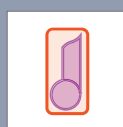

Tensor del cinturón de seguridad

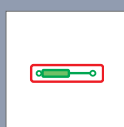

Dispositivo llenado de gas



Depósito de combustible



Válvula de seguridad

(Fecha De Publicacion: : 05/2015)



# FORD SERVICE

Tarjetas de rescate

## FORD C-MAX

Grand MAV (5+2 plazas)

11/2010 – 03/2015

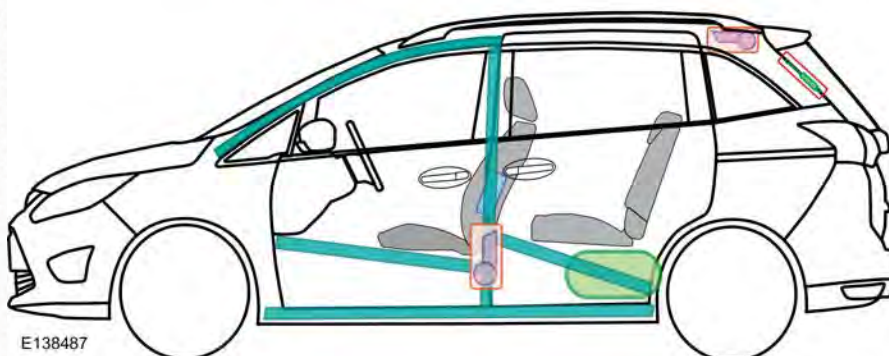
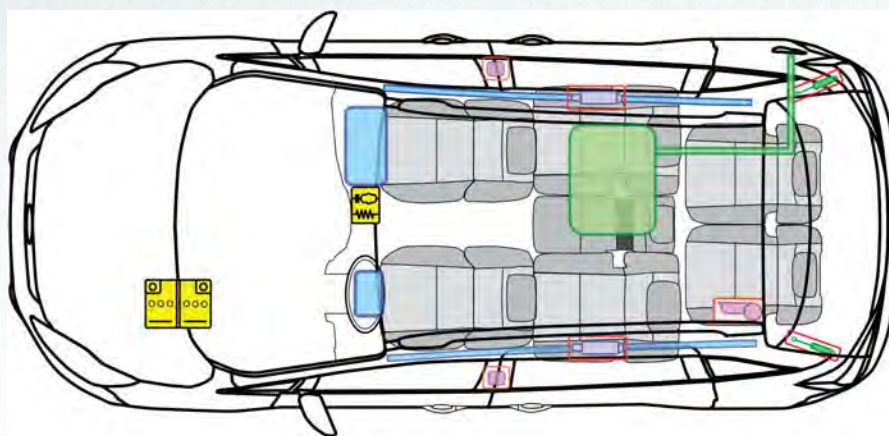

### Epígrafe

C

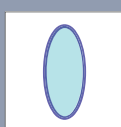

Airbag

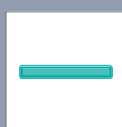

Refuerzos estructurales



Unidad de control



Sistema de protección de los peatones



Generador de gas



Protección antivuelco activa

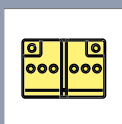

Batería

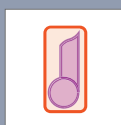

Tensor del cinturón de seguridad

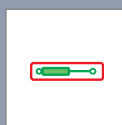

Dispositivo llenado de gas



Depósito de combustible

(Fecha De Publicacion: : 08/2012)



# FORD SERVICE

Tarjetas de rescate

## FORD C-MAX

Grand MAV (5+2 plazas)

03/2015 – >

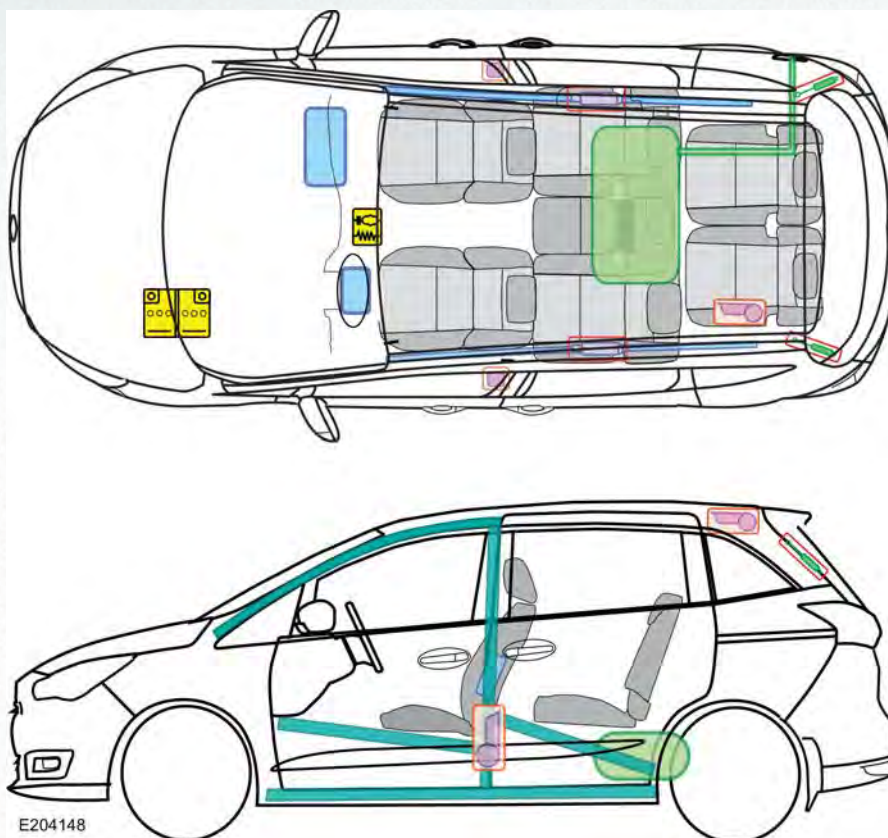

Epígrafe

C

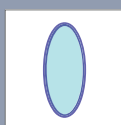

Airbag

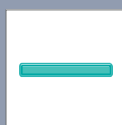

Refuerzos estructurales



Unidad de control



Sistema de protección de los peatones



Generador de gas



Protección antivuelco activa

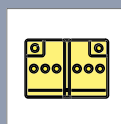

Batería

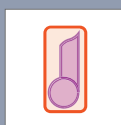

Tensor del cinturón de seguridad

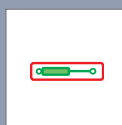

Dispositivo llenado de gas



Depósito de combustible

(Fecha De Publicacion: : 02/2017)



## FORD C-MAX E=NERGI - HEV

10/2014 – >

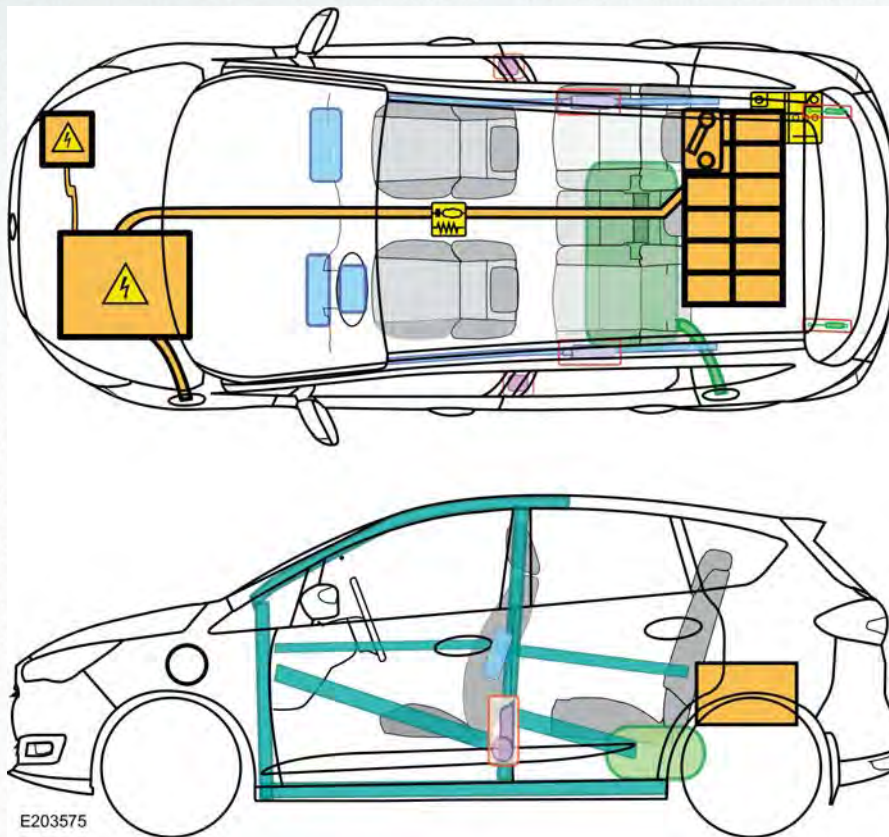

### Epígrafe

C

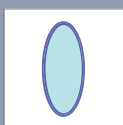

Airbag

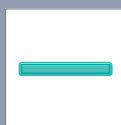

Refuerzos estructurales



Unidad de control

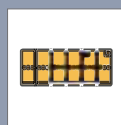

Batería de Alto Voltaje



Sistema de protección de los peatones

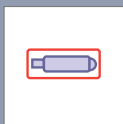

Generador de gas



Protección antivuelco activa

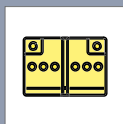

Batería

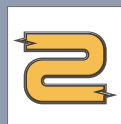

Cable de Alto Voltaje

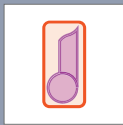

Tensor del cinturón de seguridad

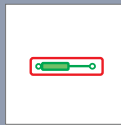

Dispositivo llenado de gas



Depósito de combustible



Punto de desconexión del Alto Voltaje

(Fecha De Publicacion: : 12/2015)

## Desactivación del sistema de alta tensión

### Introducción

**¡TENGA EN CUENTA SIEMPRE QUE EL SISTEMA DE ALTA TENSION DEL VEHICULO ESTÁ ENCENDIDO!  
ANTES DE ACCEDER AL VEHICULO, ASEGÚRESE DE QUE TODAS LAS ALIMENTACIONES ELÉCTRICAS  
EXTERNAS ESTÁN DESCONECTADAS (EJ.: CARGADOR ELÉCTRICO, HERRAMIENTAS ELÉCTRICAS).  
Si no se respetan estas advertencias, se pueden producir lesiones graves o incluso provocar la muerte.**

### IDENTIFICACIÓN DEL VEHÍCULO ELÉCTRICO

#### Identificación por el número de identificación del vehículo (VIN)

Los dígitos quinto, sexto y séptimo del número de bastidor (VIN) identifican el vehículo como C-MAX E=NERGI.



# FORD SERVICE

Tarjetas de rescate

Casillas VIN 1, 2, 3, 4, 5, 6, y 7	VEHÍCULO
WFOD	C-MAX E=NERGI
<b>VIN de muestra</b>	
WFODUOFL123456	

## Identificación por las características del vehículo



1. Etiqueta E=NERGI a ambos lados del vehículo, en las puertas delanteras, y en el portón trasero
2. Puerto de carga de alta tensión (integrado en la aleta delantera izquierda)

## Identificación por las características del compartimento motor

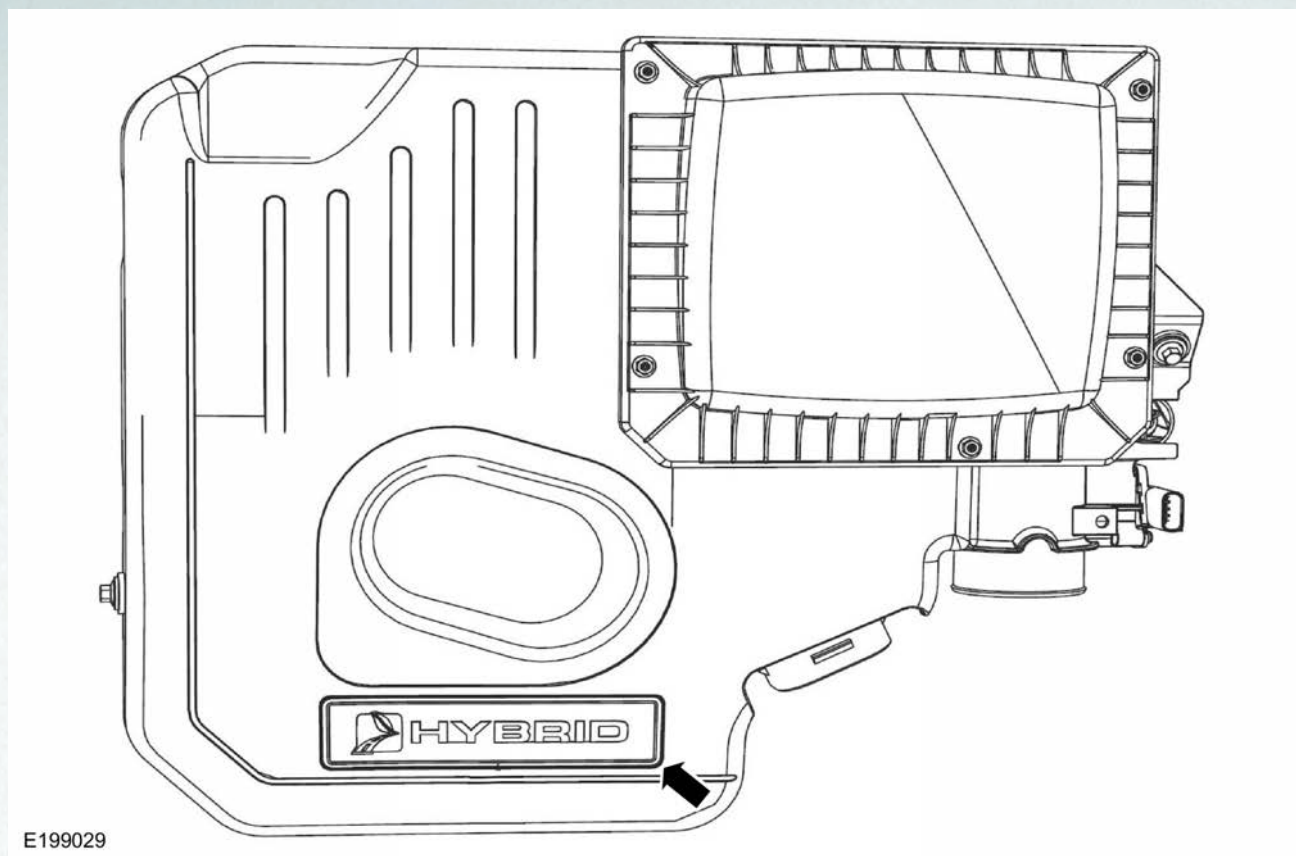

1. El vehículo C-MAX E=NERGI dispone de una cubierta de motor característica con el icono "HYBRID" en relieve.

## FUNCIONES DE DESCONEXIÓN ELÉCTRICA DE ALTA TENSIÓN

### AVISOS:

- ▲ Si desmonta la desconexión del servicio de alta tensión, se desconectará la alta tensión del vehículo. El paquete de la batería permanecerá activo y peligroso. No desconecte la carcasa de la batería de alta tensión. No manipule de ninguna manera el interior de las baterías o de la carcasa. Si es posible, aisle los componentes de alta tensión del vehículo y evite el contacto con ellos.
- ▲ Los daños en los vehículos eléctricos provocados por una colisión pueden poner en peligro los sistemas de seguridad de alta tensión y suponer un posible riesgo de descarga eléctrica de alta tensión. Extreme las precauciones y lleve siempre el equipamiento de seguridad del equipo de protección personal adecuado. Quítese todos los accesorios metálicos, incluidos reloj y anillos. Si no se respetan estas advertencias, se pueden producir lesiones graves o incluso provocar la muerte.

**Encendido en posición de desactivado** — Cuando el encendido está en posición de desactivado (y el vehículo no está cargando) el sistema de alta tensión está desactivado.

**Desconexión del servicio de alta tensión** — Cuando las desconexiones de servicio de alta tensión se desmontan, el sistema de alta tensión queda desactivado.

## Desactivación

### Método 1

Si no es posible acceder a la batería, pase al método 2.

1. Compruebe si el sistema de alta tensión está recibiendo alimentación.



E202983



# FORD SERVICE

Tarjetas de rescate

**2. Si el sistema de alta tensión está activo, pulse una vez el botón de arranque/parada del motor.**

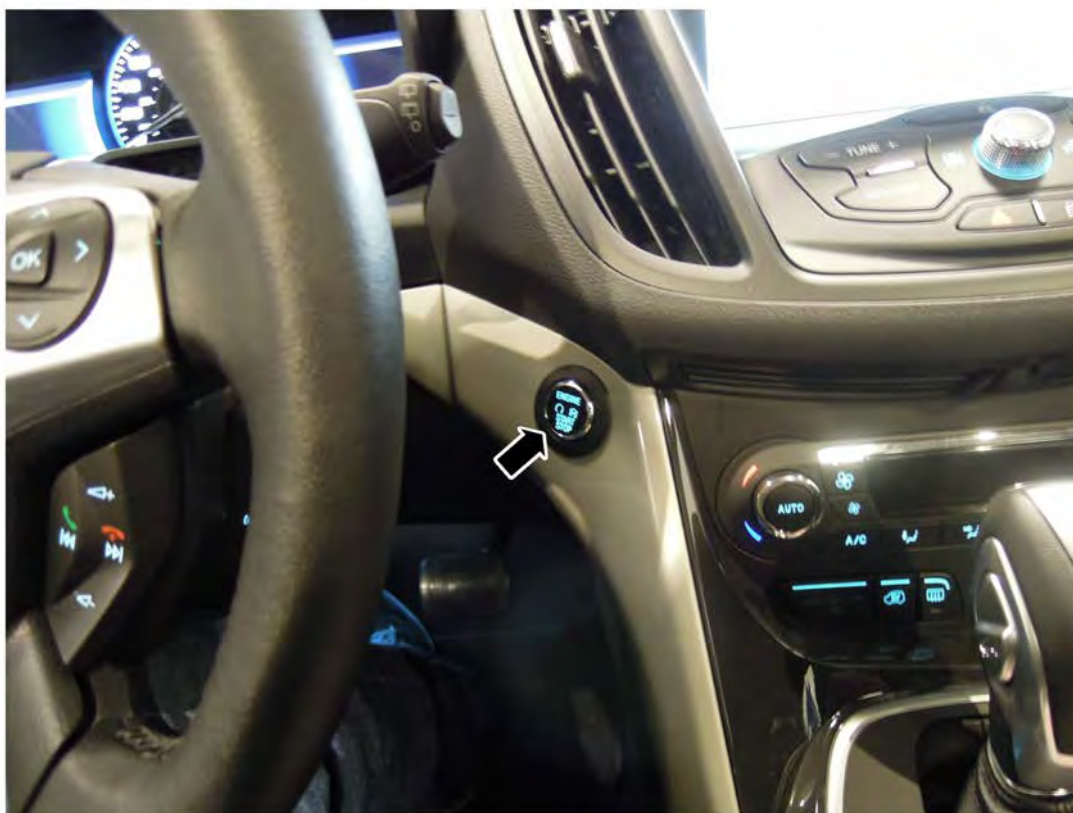

E202982

# FORD SERVICE

Tarjetas de rescate

## 3. Desmonte la cubierta para acceder a la batería de 12 V.

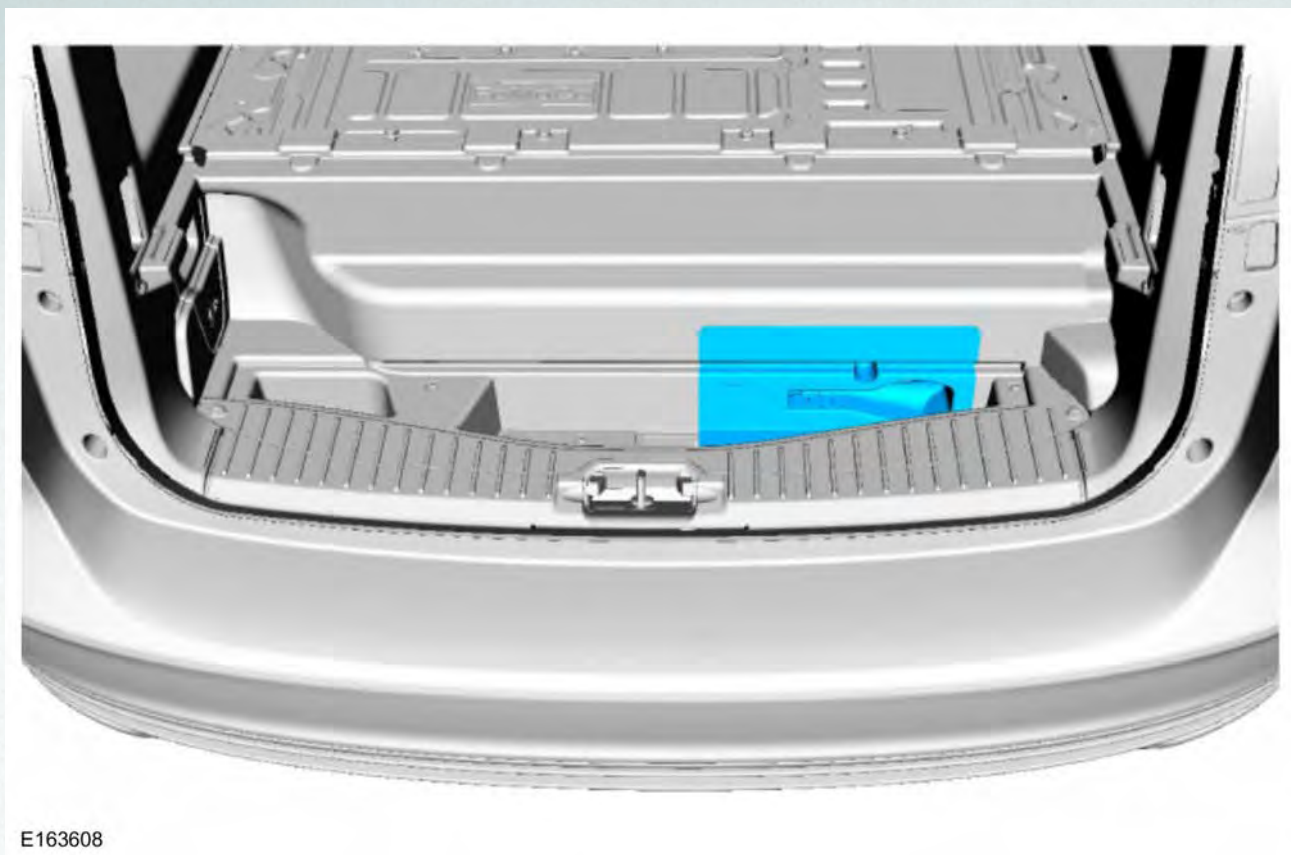

E163608

## 4. Desconecte el cable de la batería de 12 V.

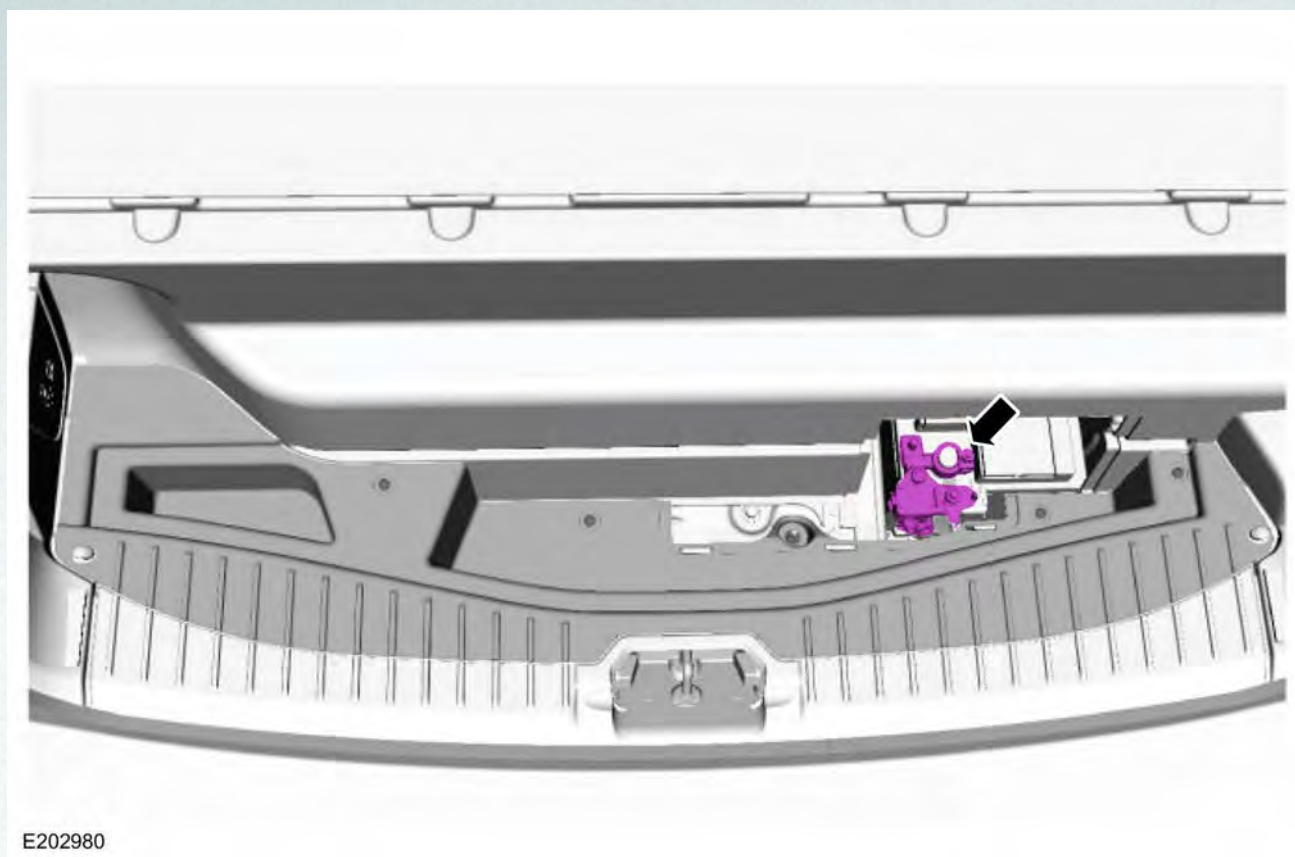

E202980

## Método 2

**NOTA:** Para acceder a la desconexión del servicio de alta tensión, debe bajar el respaldo del asiento trasero hasta el 40% de su recorrido.

1. Localice la palanca de desbloqueo del respaldo del asiento, en la parte superior del respaldo.

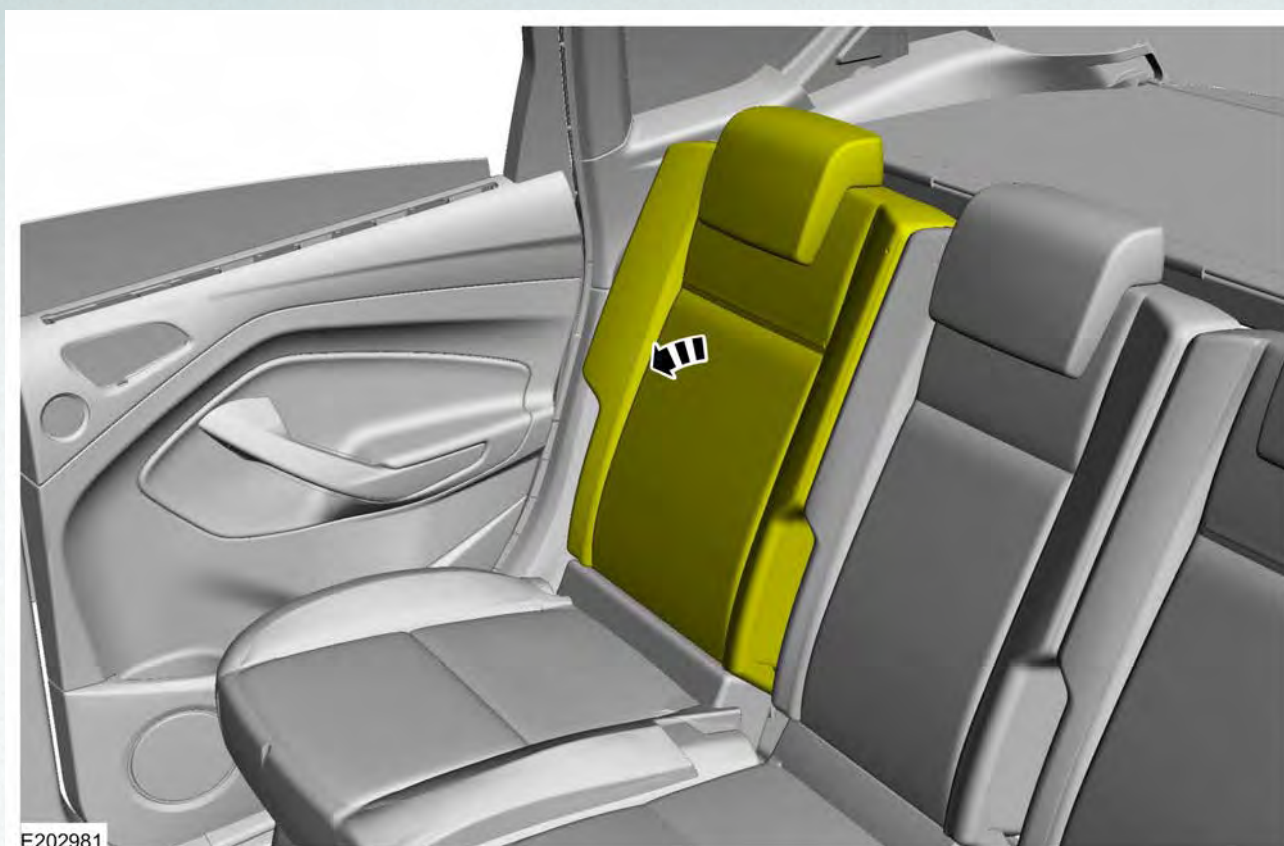

E202981

## 2. Retire la cubierta para acceder a la desconexión superior del servicio de la batería.

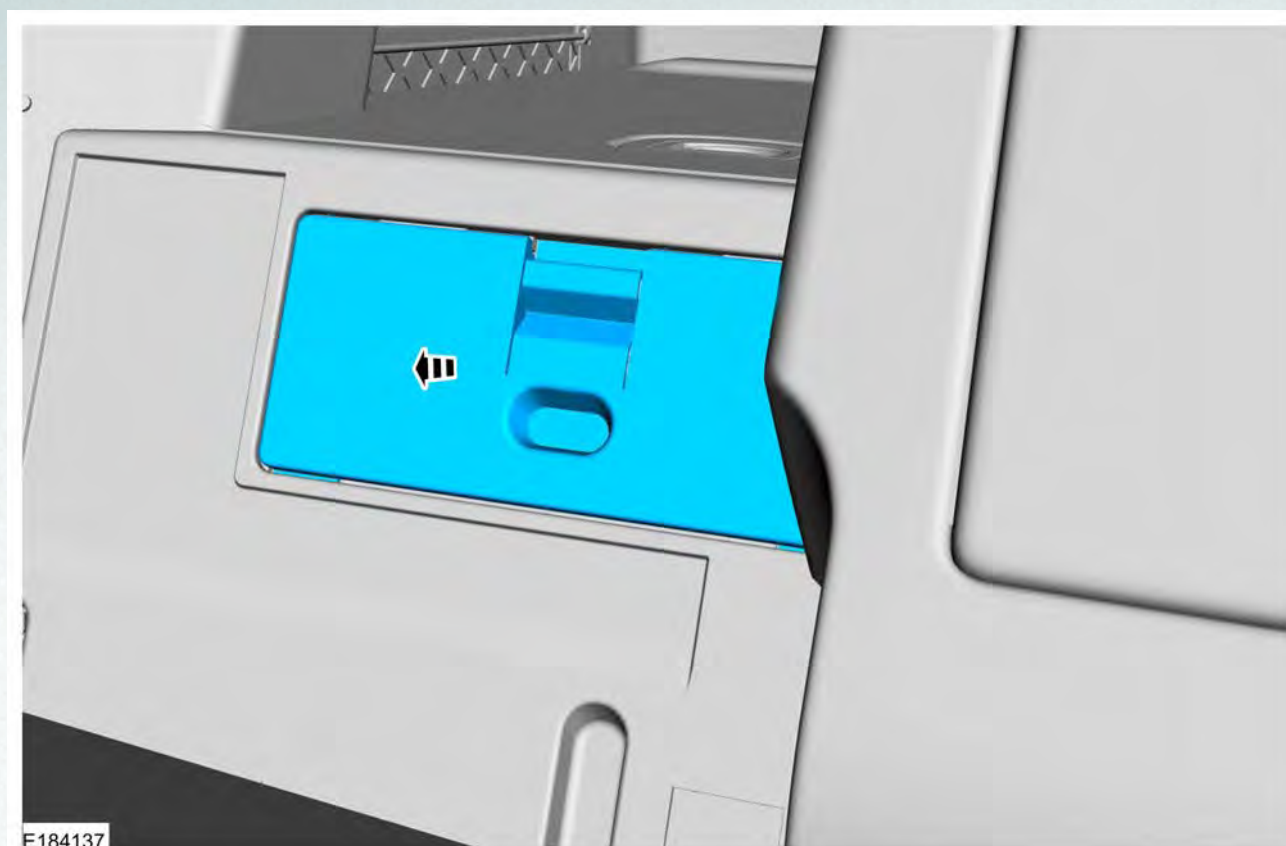

E184137

### 3. Desmonte la desconexión del servicio de alta tensión.

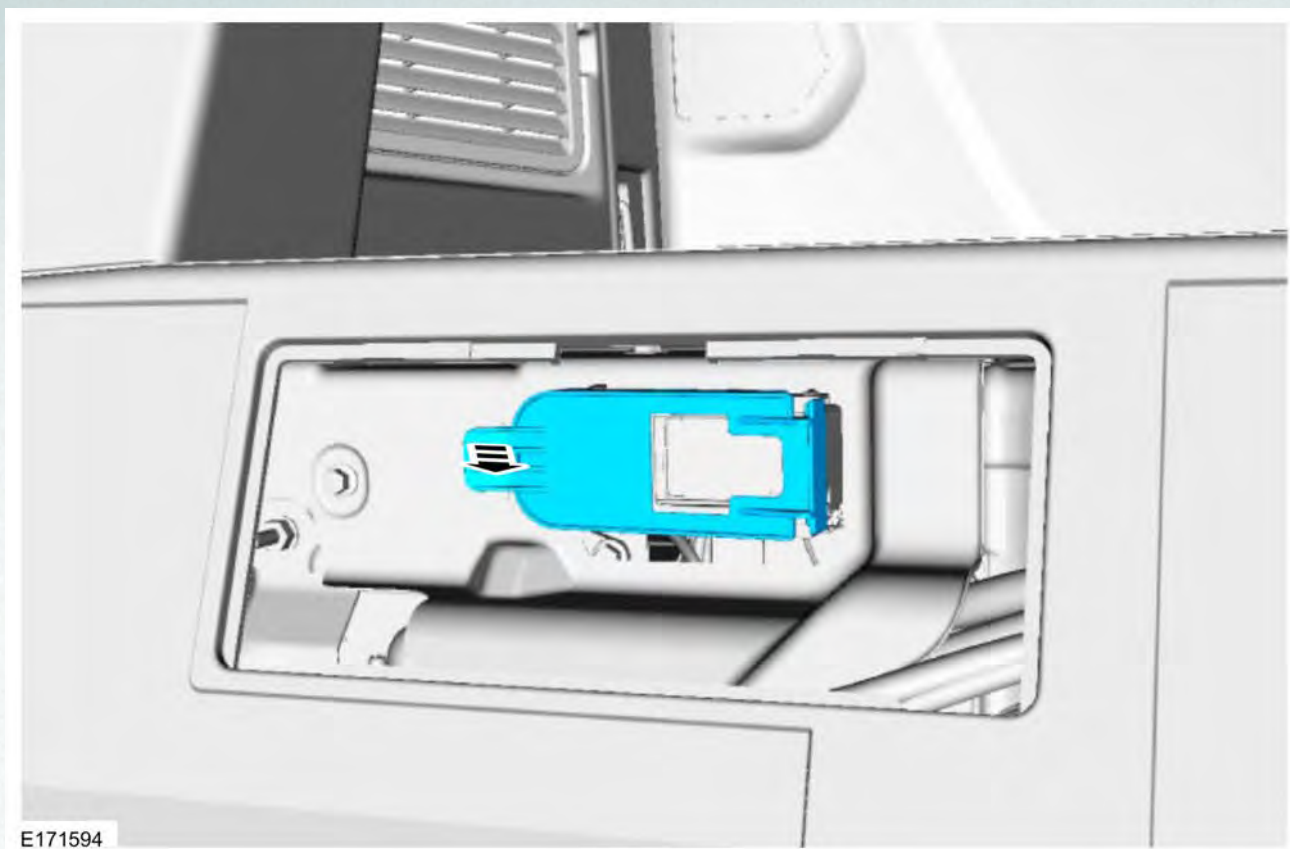

E171594

## 4. Desmonte la desconexión del servicio de alta tensión.

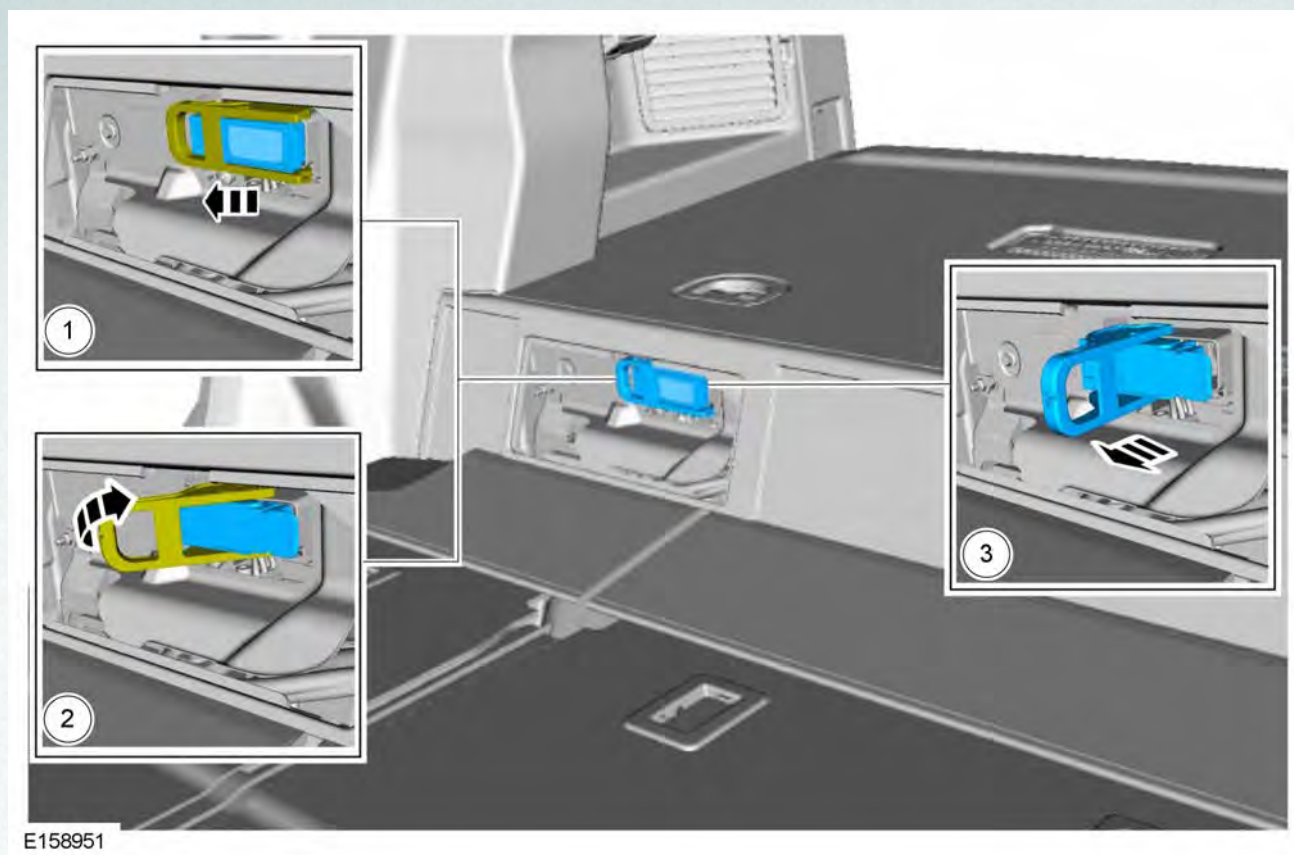

(Fecha De Publicacion: : 12/2015)

# FORD SERVICE

Tarjetas de rescate

## FORD Eco Sport

09/2013 – >



E178558

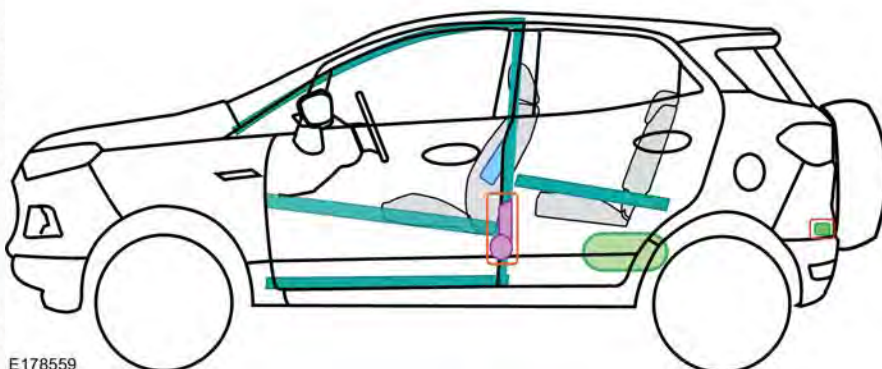
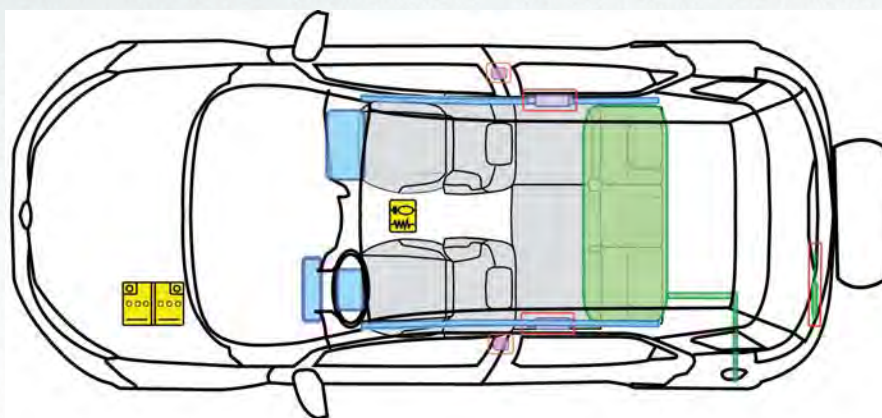

E178559

### Epígrafe

E

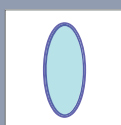

Airbag

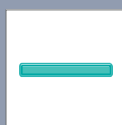

Refuerzos estructurales



Unidad de control



Sistema de protección de los peatones



Generador de gas



Protección antivuelco activa

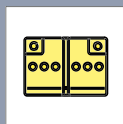

Batería

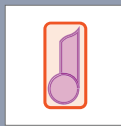

Tensor del cinturón de seguridad

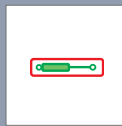

Dispositivo llenado de gas

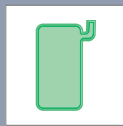

Depósito de combustible

(Fecha De Publicacion: : 11/2017)





# FORD SERVICE

Tarjetas de rescate

## FORD Edge

06/2018 – >



E303279

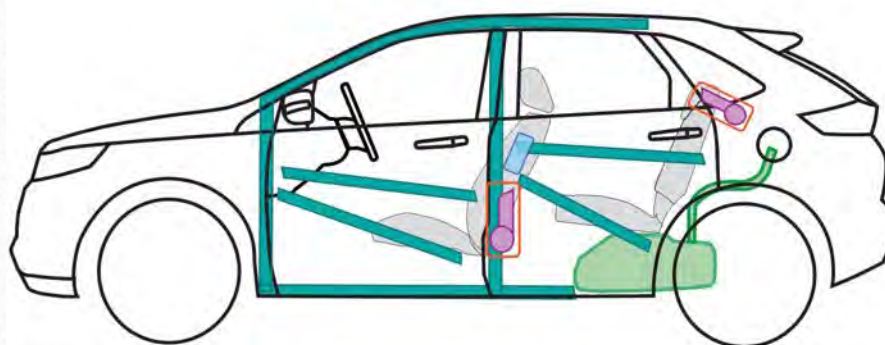
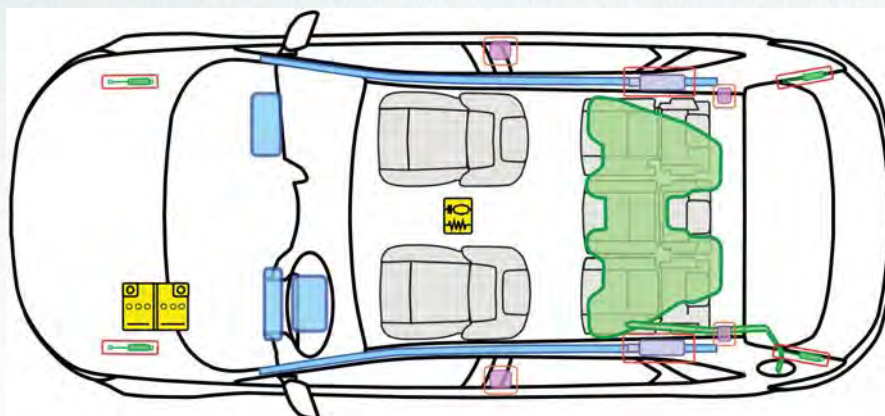

E303280

### Epígrafe

E

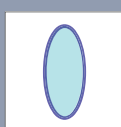

Airbag

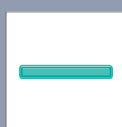

Refuerzos estructurales



Unidad de control



Sistema de protección de los peatones



Generador de gas



Protección antivuelco activa

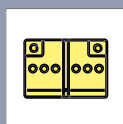

Batería

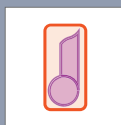

Tensor del cinturón de seguridad

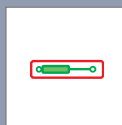

Dispositivo llenado de gas



Depósito de combustible

(Fecha De Publicacion: : 05/2019)



# FORD SERVICE

Tarjetas de rescate

FORD **Edge**  
SUV 5 puertas

10/2015 – 06/2018

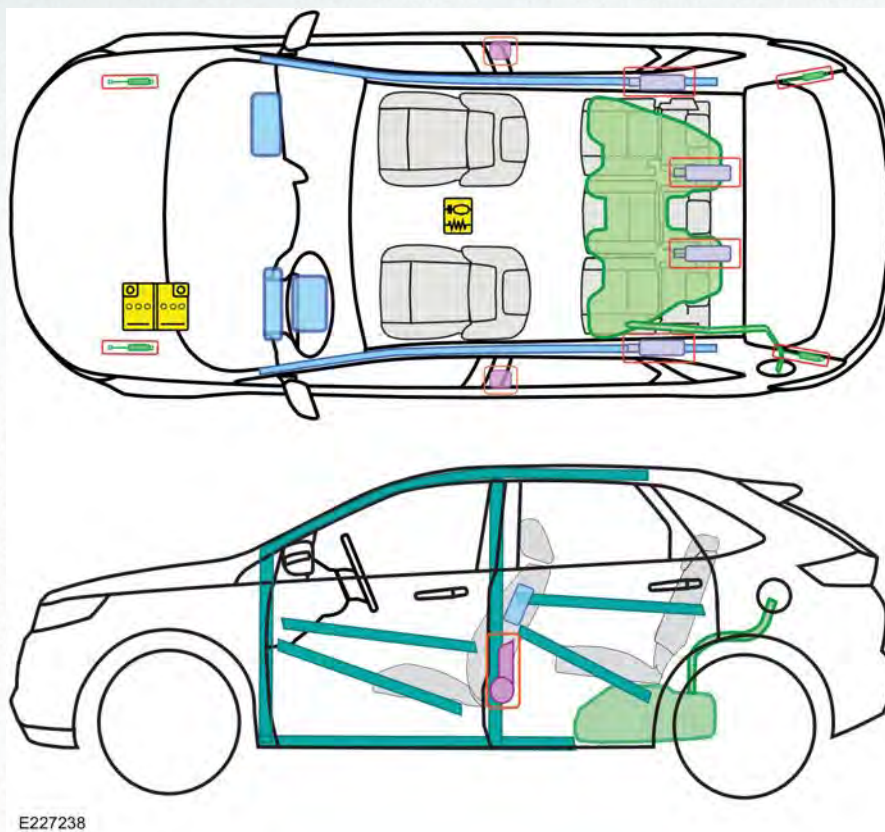

E227238

## Epígrafe

E

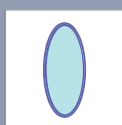

Airbag

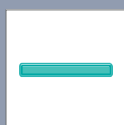

Refuerzos  
estructurales



Unidad de  
control



Sistema de  
protección de  
los peatones

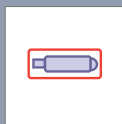

Generador de  
gas



Protección  
antivuelco  
activa

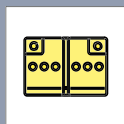

Batería

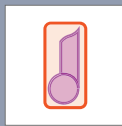

Tensor del  
cinturón de  
seguridad

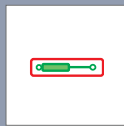

Dispositivo  
llenado de gas



Depósito de  
combustible

(Fecha De Publicacion: : 01/2016)



### FORD Explorer PHEV - HEV



E324739

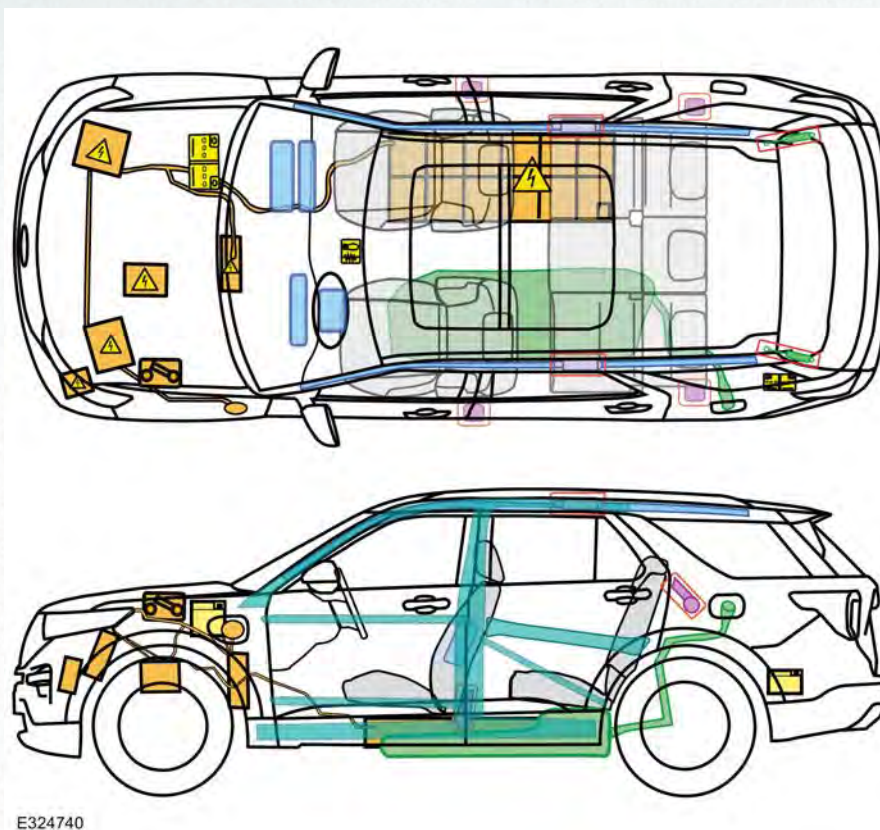

E324740

#### Epígrafe

E

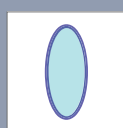

Airbag

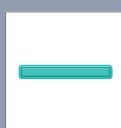

Refuerzos estructurales



Unidad de control



Batería de Alto Voltaje



Sistema de protección de los peatones



Generador de gas



Protección antivuelco activa

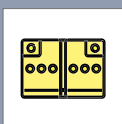

Batería

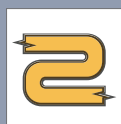

Cable de Alto Voltaje

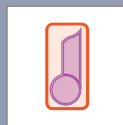

Tensor del cinturón de seguridad

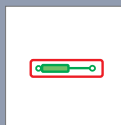

Dispositivo llenado de gas



Depósito de combustible



Punto de desconexión del Alto Voltaje

(Fecha De Publicacion: : 04/2020)

## IDENTIFICACIÓN DEL VEHÍCULO ELÉCTRICO

### Identificación por las características del vehículo



1. Puerto de carga de alta tensión
2. Distintivo de vehículo híbrido

### Desactivación del sistema de alta tensión

**¡TENGA EN CUENTA SIEMPRE QUE EL SISTEMA DE ALTA TENSIÓN DEL VEHÍCULO ESTÁ ENCENDIDO!  
ANTES DE ACCEDER AL VEHÍCULO, ASEGÚRESE DE QUE TODAS LAS ALIMENTACIONES ELÉCTRICAS  
EXTERNAS ESTÁN DESCONECTADAS (EJ.: CARGADOR ELÉCTRICO, HERRAMIENTAS ELÉCTRICAS).  
Si no se respetan estas advertencias, se pueden producir lesiones graves o incluso provocar la muerte.**

### FUNCIONES DE DESCONEXIÓN ELÉCTRICA DE ALTA TENSIÓN

#### AVISOS:

- ⚠ Si desmonta la desconexión del servicio, se desconectará la alta tensión del vehículo. El paquete de la batería de alta tensión permanecerá activo y peligroso. No desconecte la carcasa de la batería de alta tensión. No manipule de ninguna manera el interior de las baterías de alta tensión o de la**

carcasa. Si es posible, aisle los componentes de alta tensión del vehículo y evite el contacto con ellos.

 Los daños en los vehículos eléctricos provocados por una colisión pueden poner en peligro los sistemas de seguridad de alta tensión y suponer un posible riesgo de descarga eléctrica de alta tensión. Extreme las precauciones y lleve siempre el equipamiento de seguridad del equipo de protección personal adecuado. Quítese todos los accesorios metálicos, incluidos reloj y anillos. Si no se respetan estas advertencias, se pueden producir lesiones graves o incluso provocar la muerte.

**Encendido en posición de desactivado:** cuando el encendido está en posición de desactivado (y el vehículo no está cargando) el sistema de alta tensión está desactivado.

**Desconexión del servicio:** cuando las desconexiones de servicio se desmontan, el sistema de alta tensión queda desactivado.

### Desactivación del sistema de alta tensión-Método 1

Si no es posible acceder a la batería de 12 V, pase al método 2.

1. Compruebe si el sistema de alta tensión está recibiendo alimentación.



# FORD SERVICE

Tarjetas de rescate

**2. Si el sistema de alta tensión está activo, apague el encendido.**



**NOTA:** No hay ningún pestillo secundario debajo del capó.

### 3. Abra el capó.

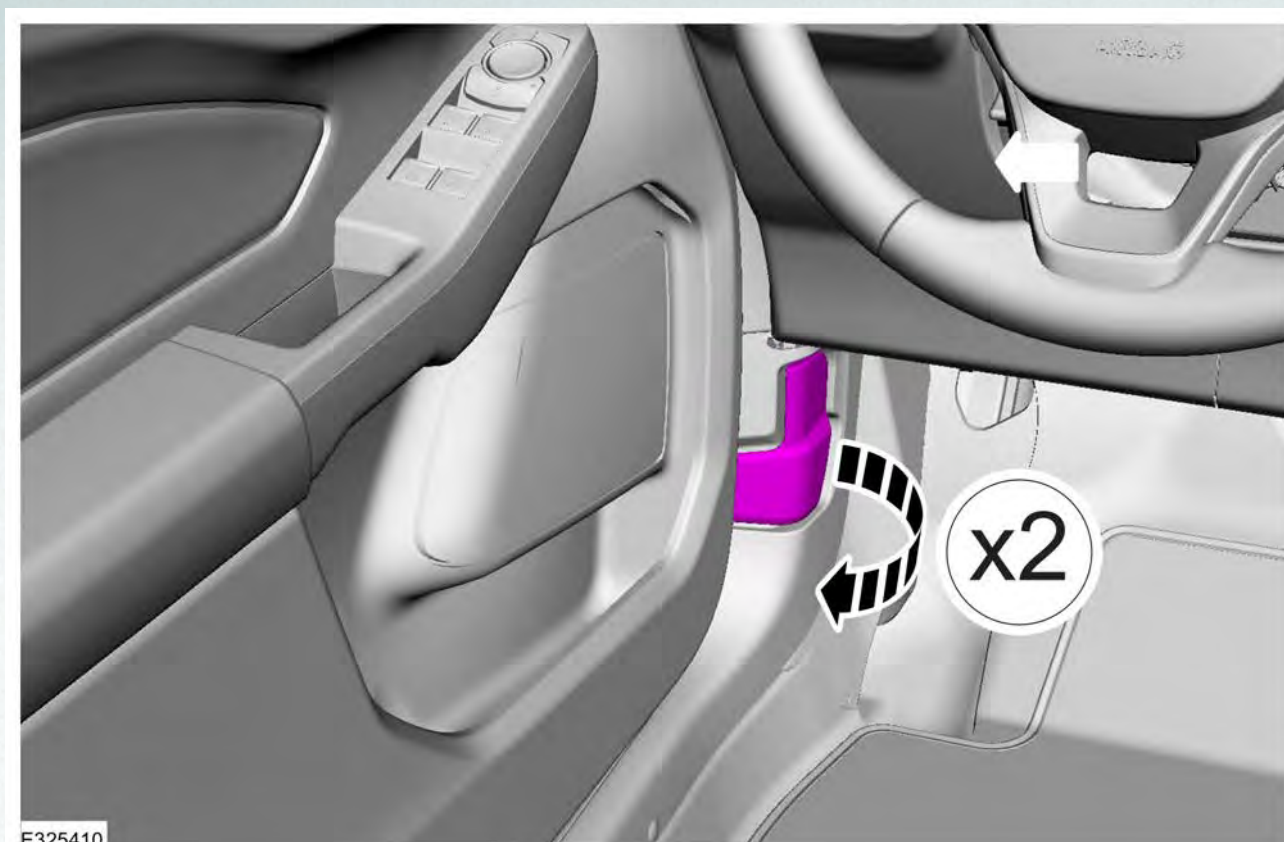

E325410

4.

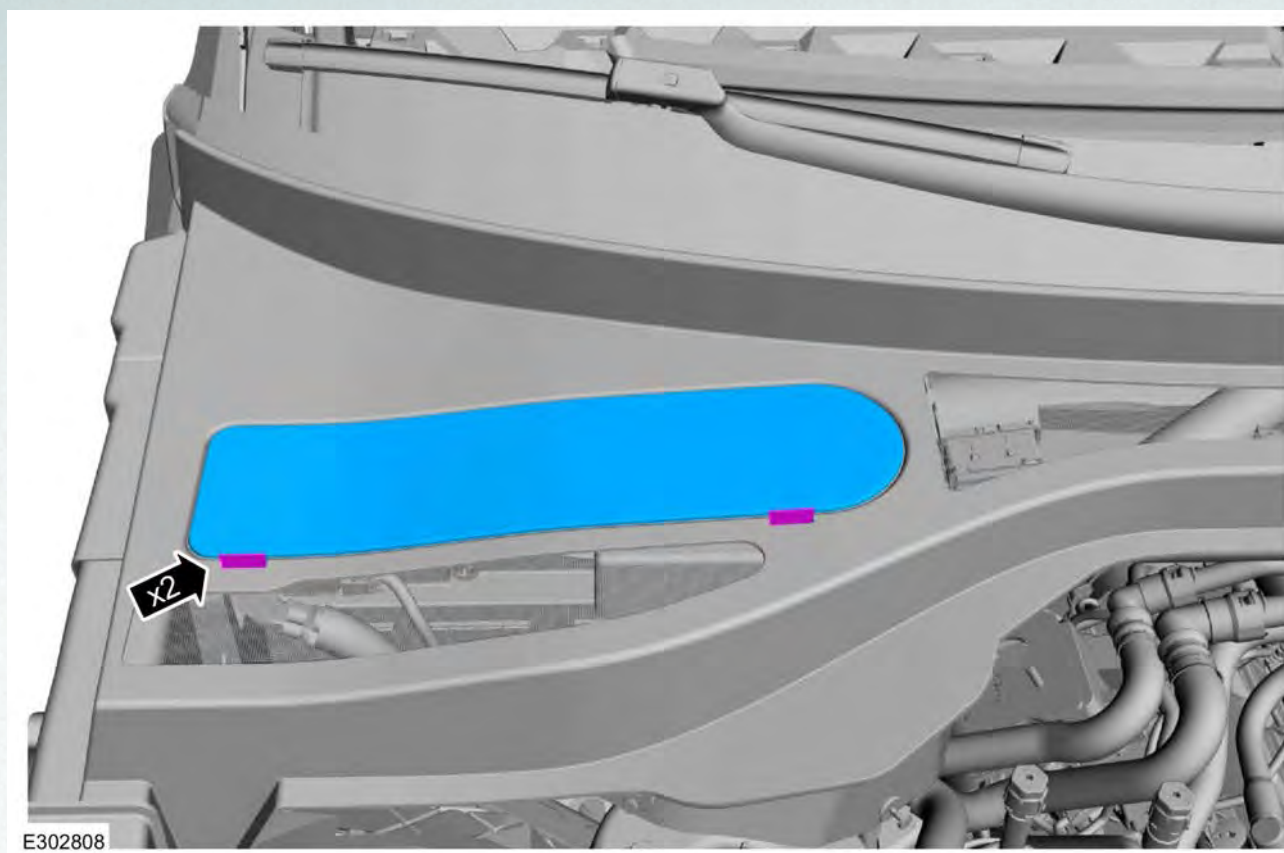

**NOTA:** Al desconectar la batería para interrumpir la alimentación al sistema eléctrico del vehículo, desconecte solo el o los cables de masa de la batería. No es necesario desconectar el o los cables positivos de la batería.



5.

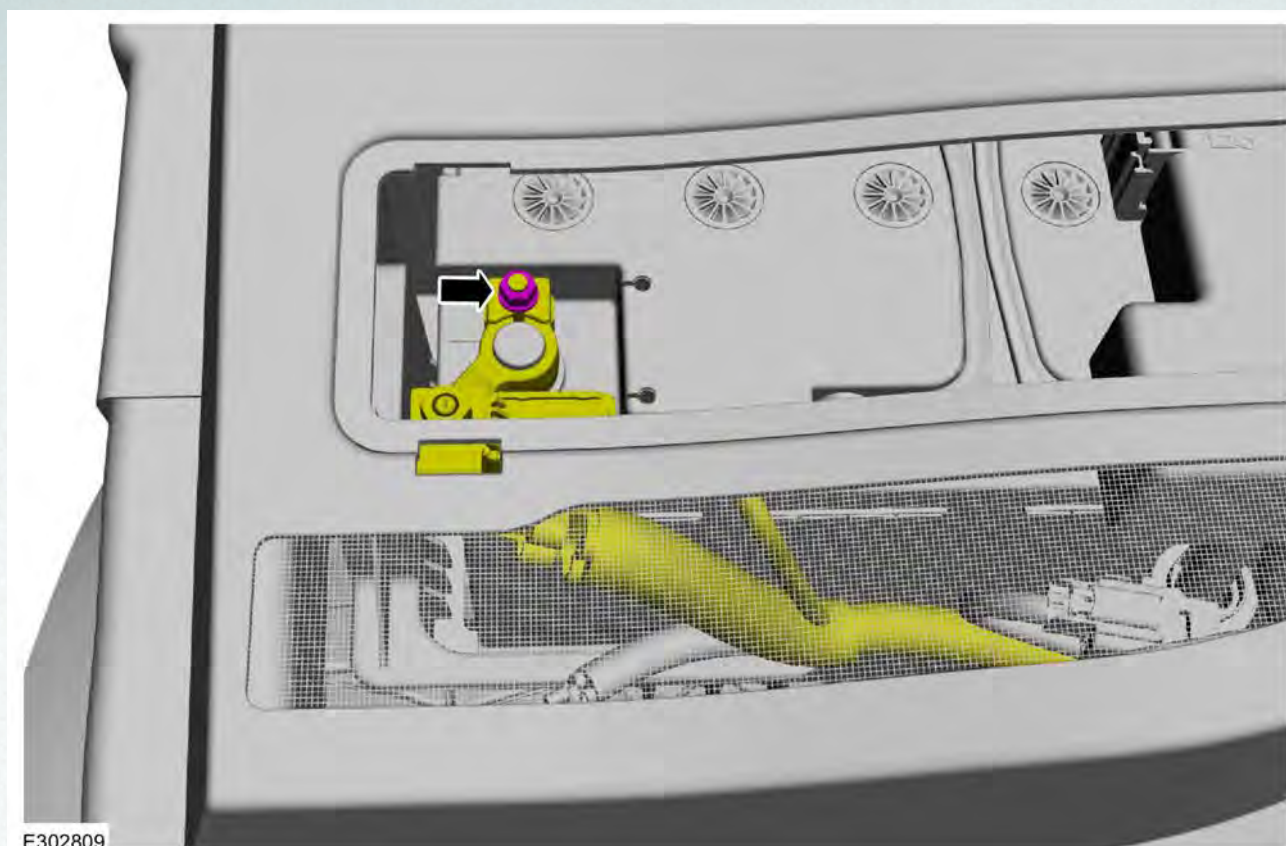

6.

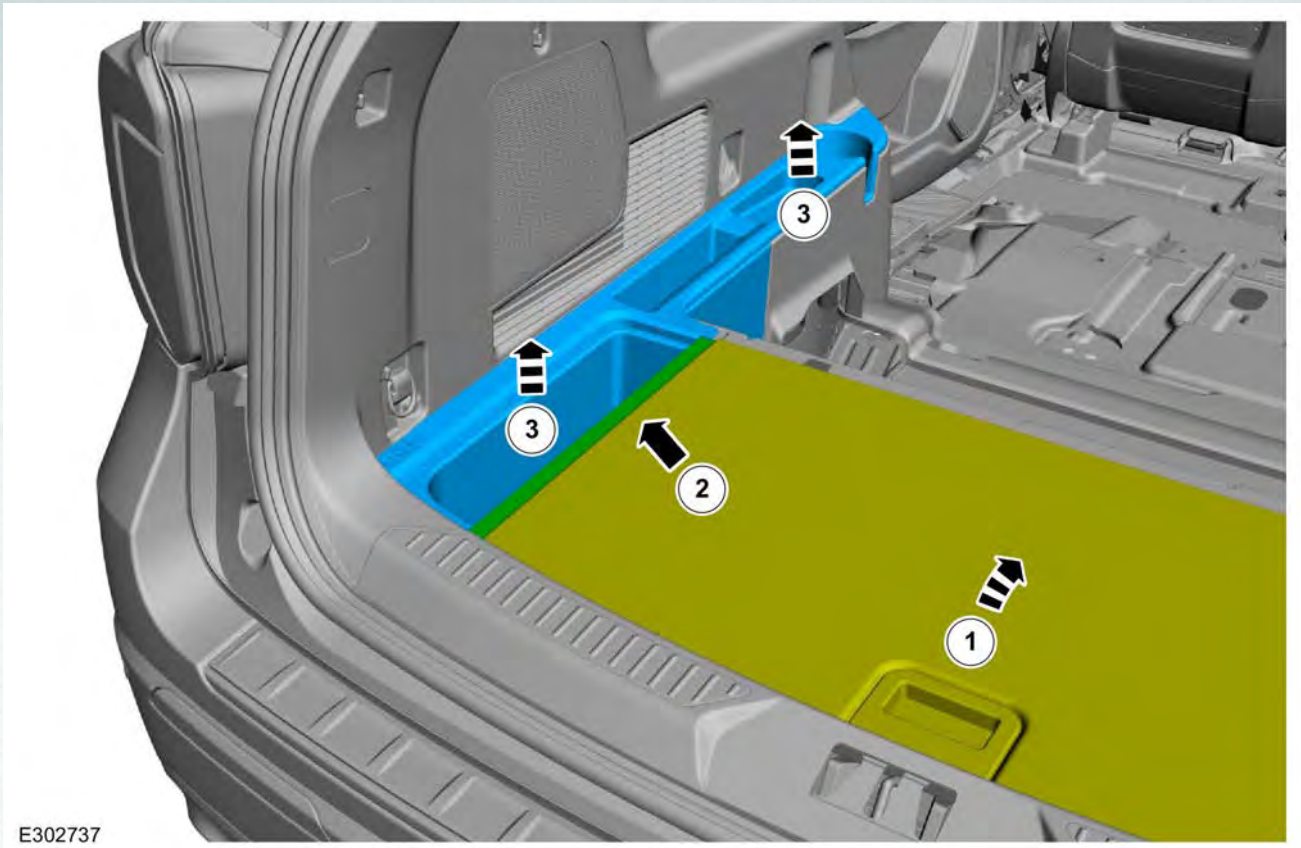

E302737

# FORD SERVICE

Tarjetas de rescate

7.



E300820

8.

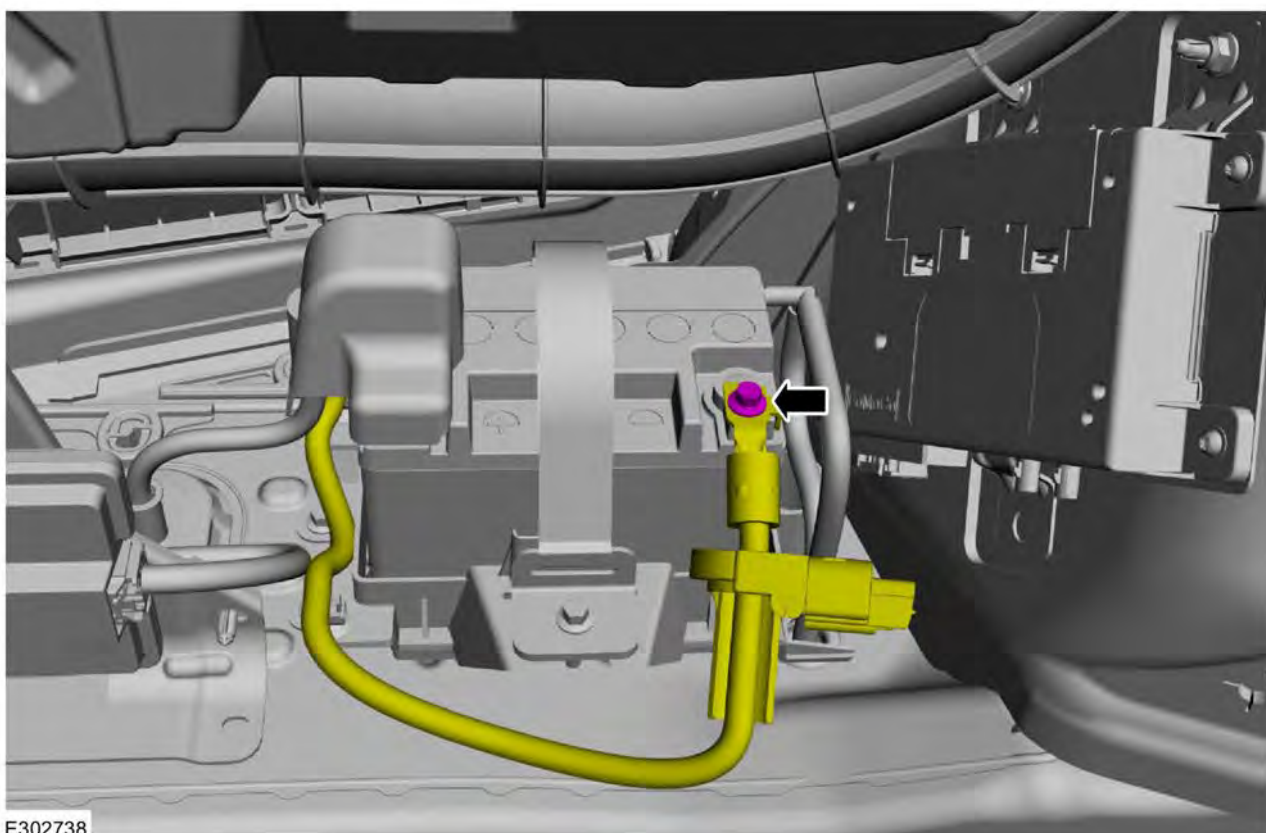

E302738

9.

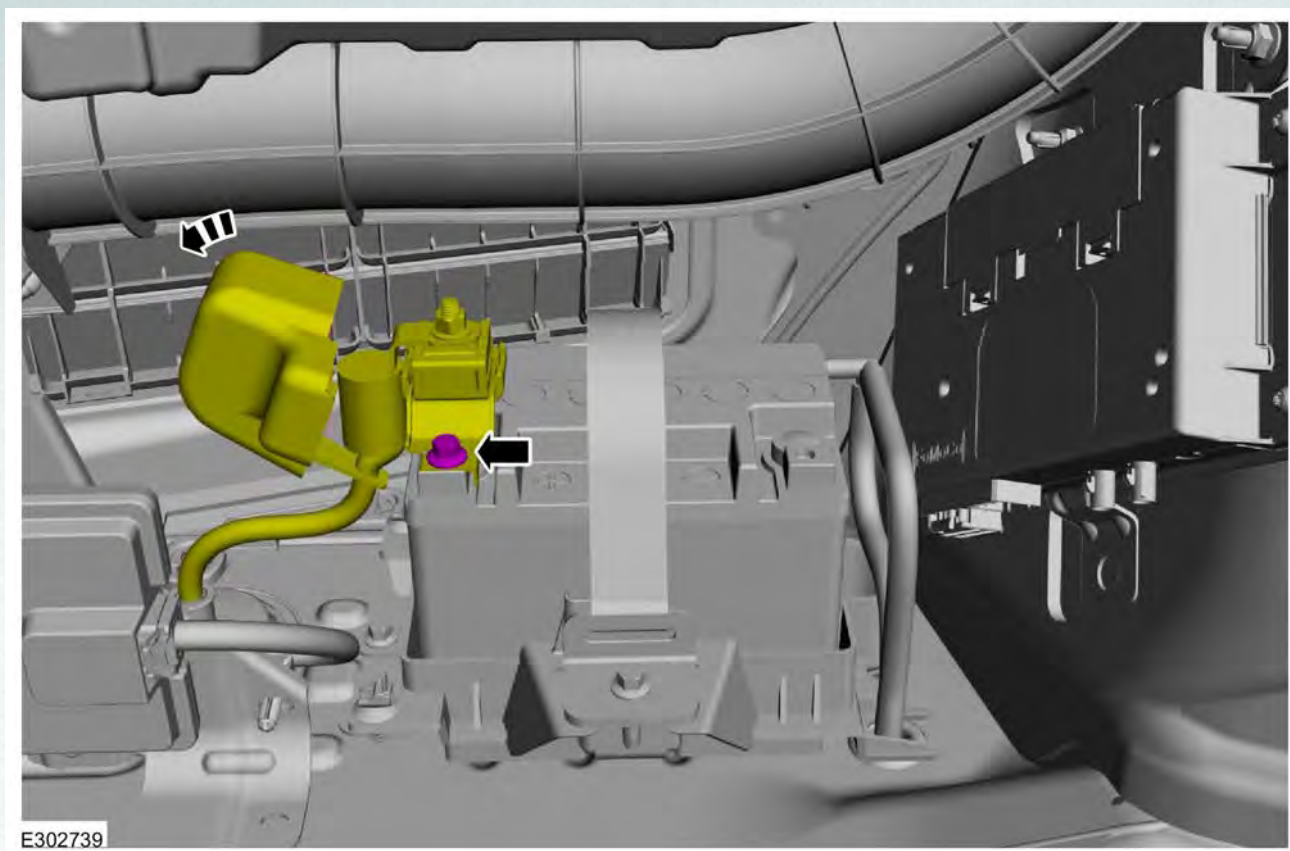

### Desactivación del sistema de alta tensión-Método 2

El sistema de batería de alta tensión utiliza un conector de desconexión de baja tensión que abre el circuito de alimentación del control del contactor de 12 voltios y se encuentra en el compartimento motor. Cuando se desconecta el conector de desconexión de servicio, los contactores de alta tensión que suministran alta tensión al vehículo no pueden cerrarse.

#### 1. Abra el capó.



## 2. Ubicación de la desconexión de servicio.

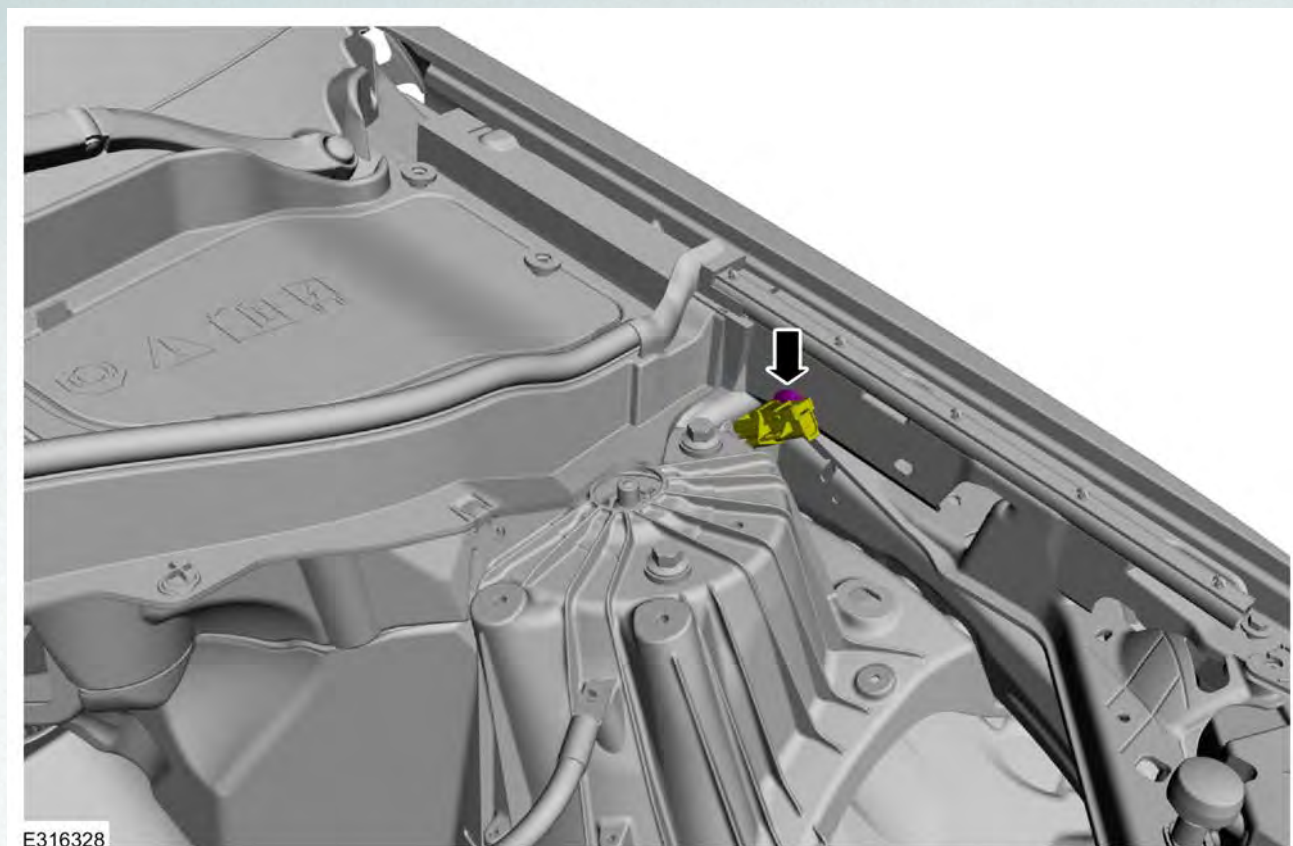

E316328

# FORD SERVICE

Tarjetas de rescate

3.

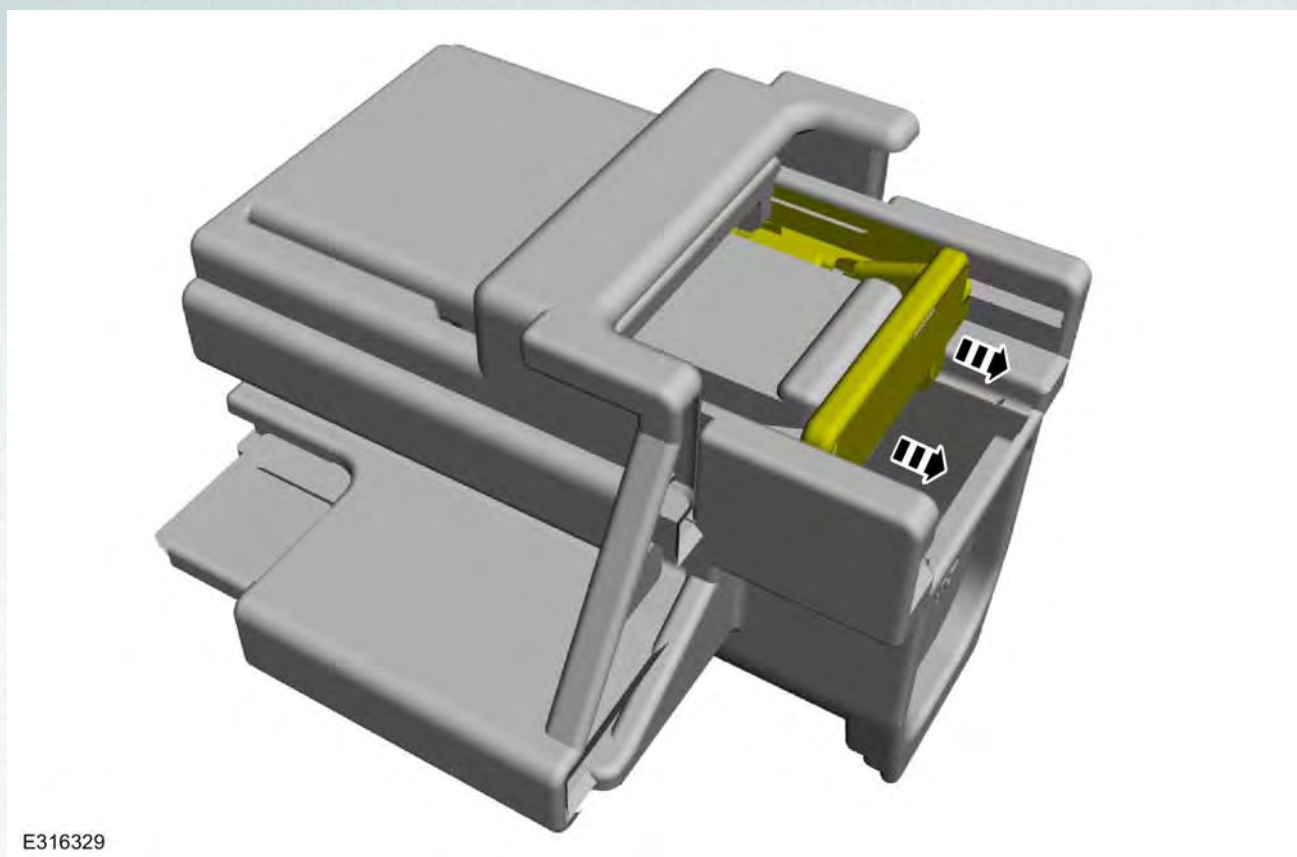

E316329

# FORD SERVICE

Tarjetas de rescate

4. Tire de la parte superior hacia arriba hasta que se vea la palabra "OFF". No es posible desmontar la pieza deslizante de la cabecera.

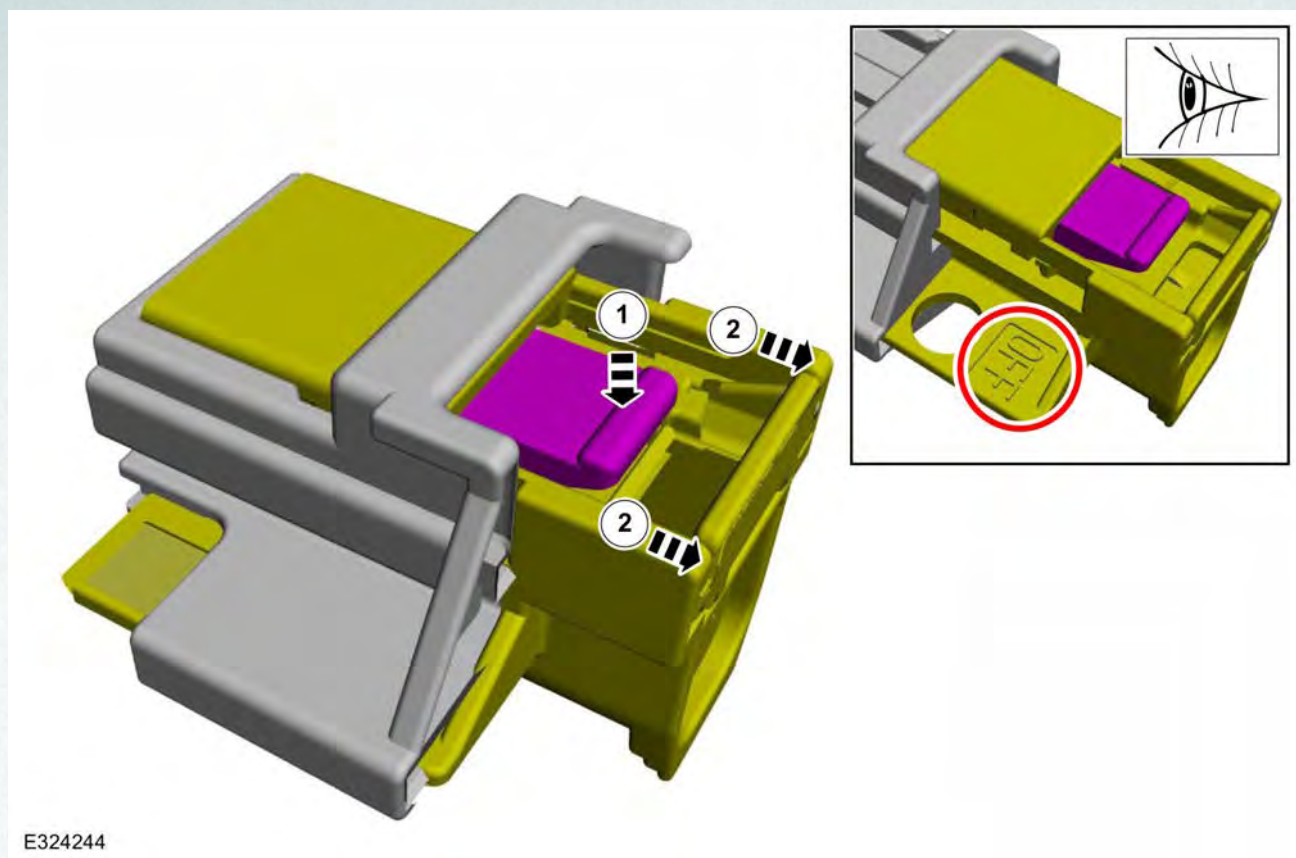



5.

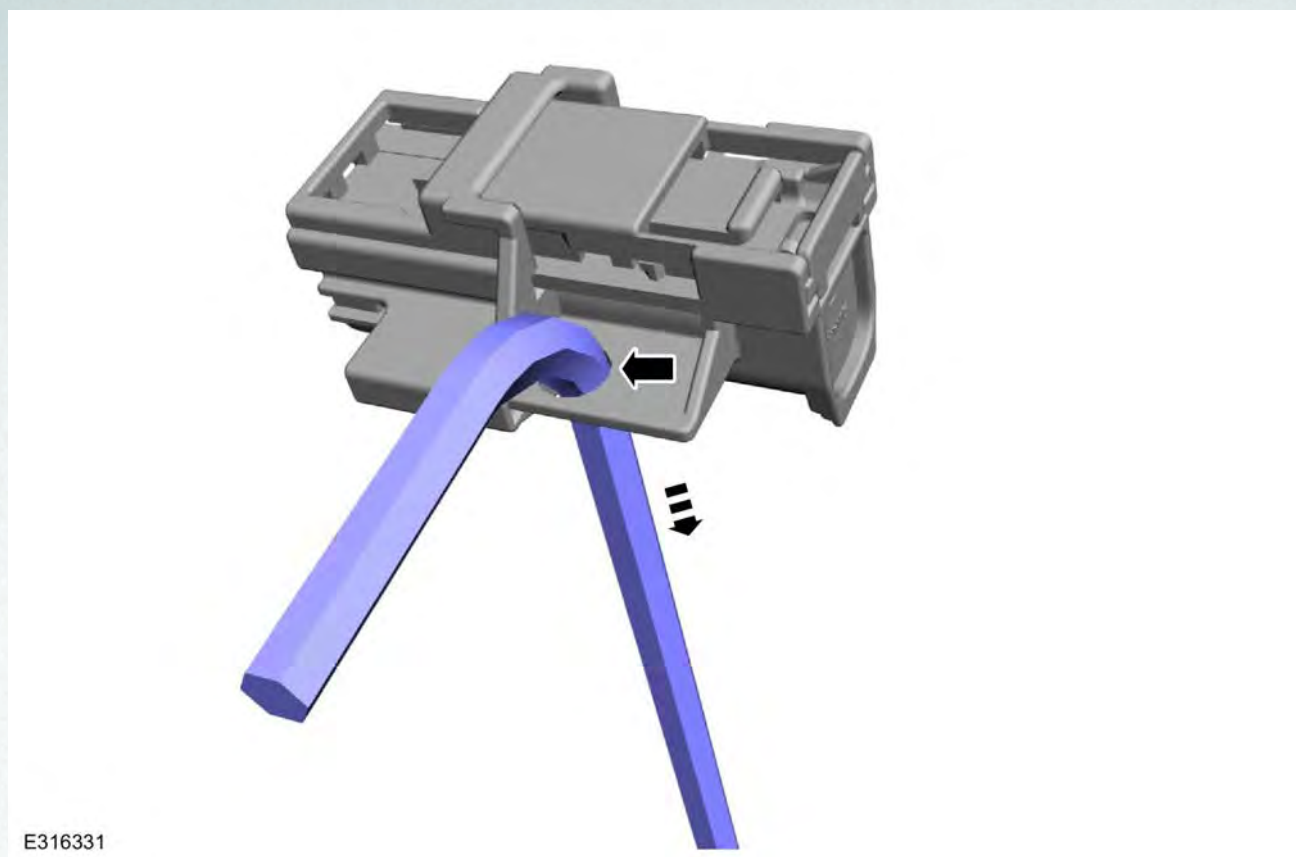

6. Espere un mínimo de 5 minutos

(Fecha De Publicacion: : 04/2020)

# FORD SERVICE

Tarjetas de rescate

## FORD Fiesta

01/1996 – 02/2000

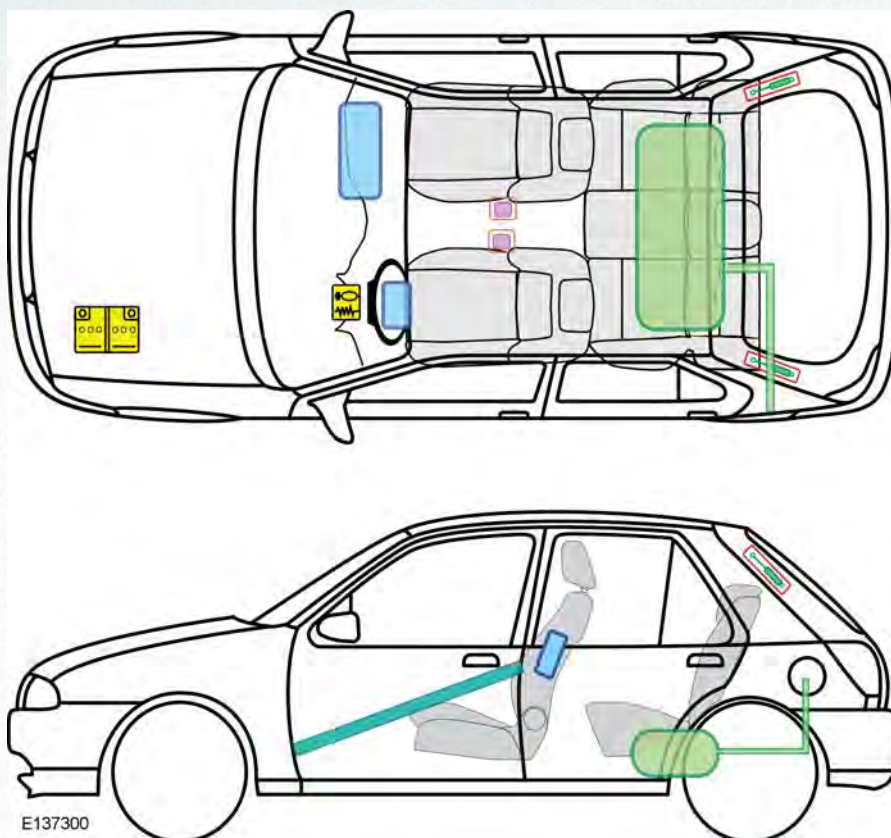

### Epígrafe

F

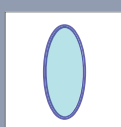

Airbag

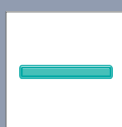

Refuerzos estructurales



Unidad de control



Sistema de protección de los peatones



Generador de gas



Protección antivuelco activa

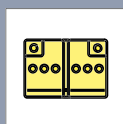

Batería

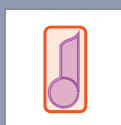

Tensor del cinturón de seguridad

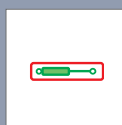

Dispositivo llenado de gas



Depósito de combustible

(Fecha De Publicacion: : 01/2011)

# FORD SERVICE

Tarjetas de rescate

## FORD Fiesta

02/2000 – 02/2002



E170168

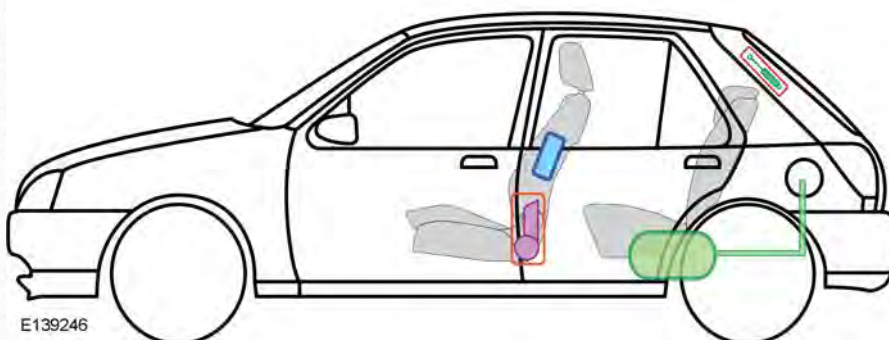
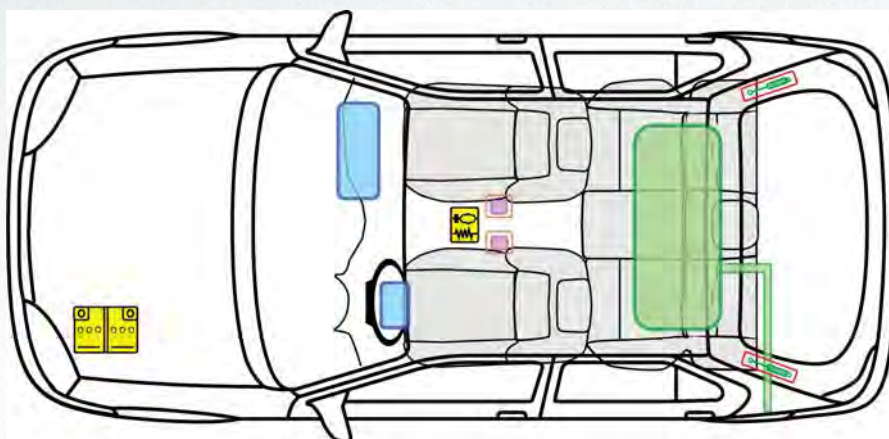

E139246

### Epígrafe

F

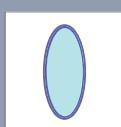

Airbag

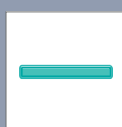

Refuerzos estructurales



Unidad de control



Sistema de protección de los peatones



Generador de gas



Protección antivuelco activa

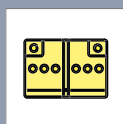

Batería

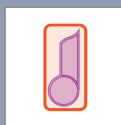

Tensor del cinturón de seguridad

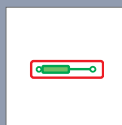

Dispositivo llenado de gas

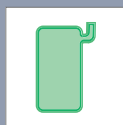

Depósito de combustible

(Fecha De Publicacion: : 05/2013)



# FORD SERVICE

Tarjetas de rescate

## FORD Fiesta

3 puertas

06/2008 – 04/2017

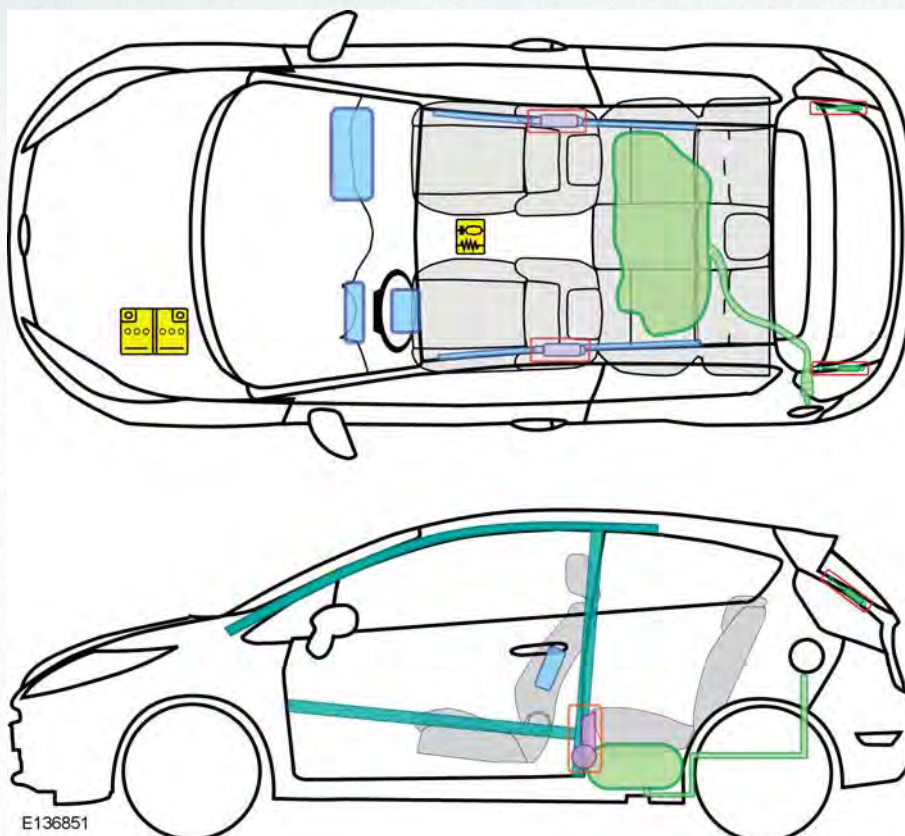

E136851

### Epígrafe

F

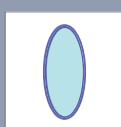

Airbag

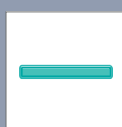

Refuerzos estructurales



Unidad de control



Sistema de protección de los peatones



Generador de gas



Protección antivuelco activa

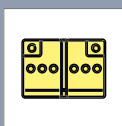

Batería

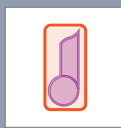

Tensor del cinturón de seguridad

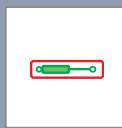

Dispositivo llenado de gas



Depósito de combustible

(Fecha De Publicacion: : 03/2011)



# FORD SERVICE

Tarjetas de rescate

## FORD Fiesta

3 puertas

11/2001 – 09/2008

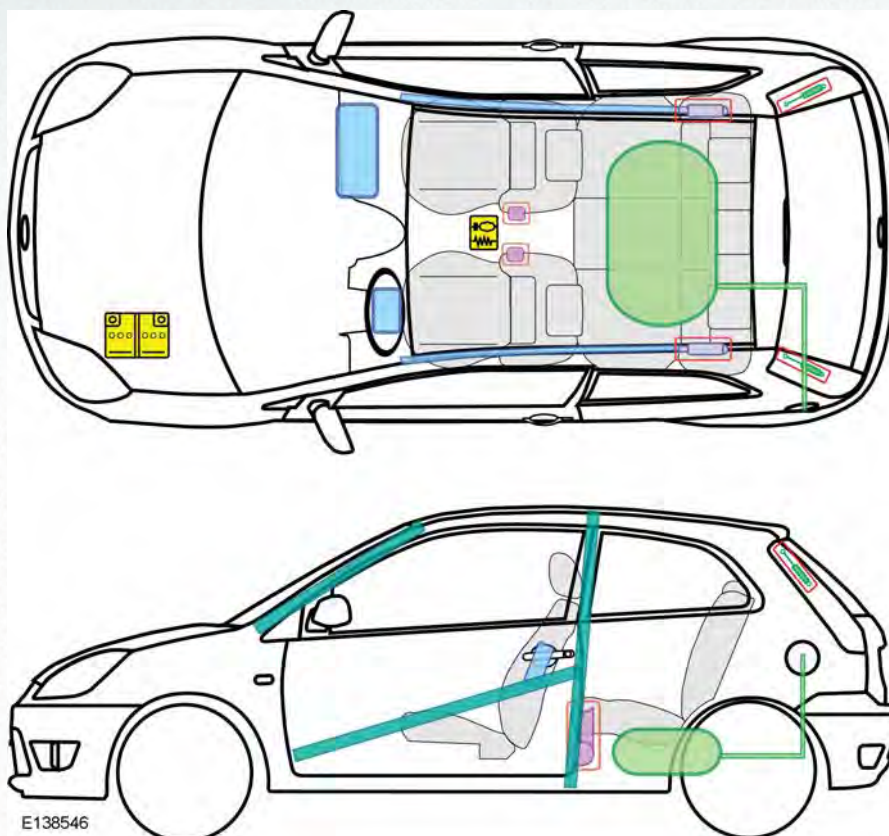

### Epígrafe

F

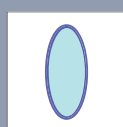

Airbag

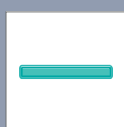

Refuerzos estructurales



Unidad de control



Sistema de protección de los peatones



Generador de gas



Protección antivuelco activa

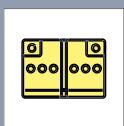

Batería

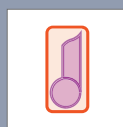

Tensor del cinturón de seguridad



Dispositivo llenado de gas



Depósito de combustible

(Fecha De Publicacion: : 03/2011)



# FORD SERVICE

Tarjetas de rescate

## FORD Fiesta

3 puertas

04/2017 - >

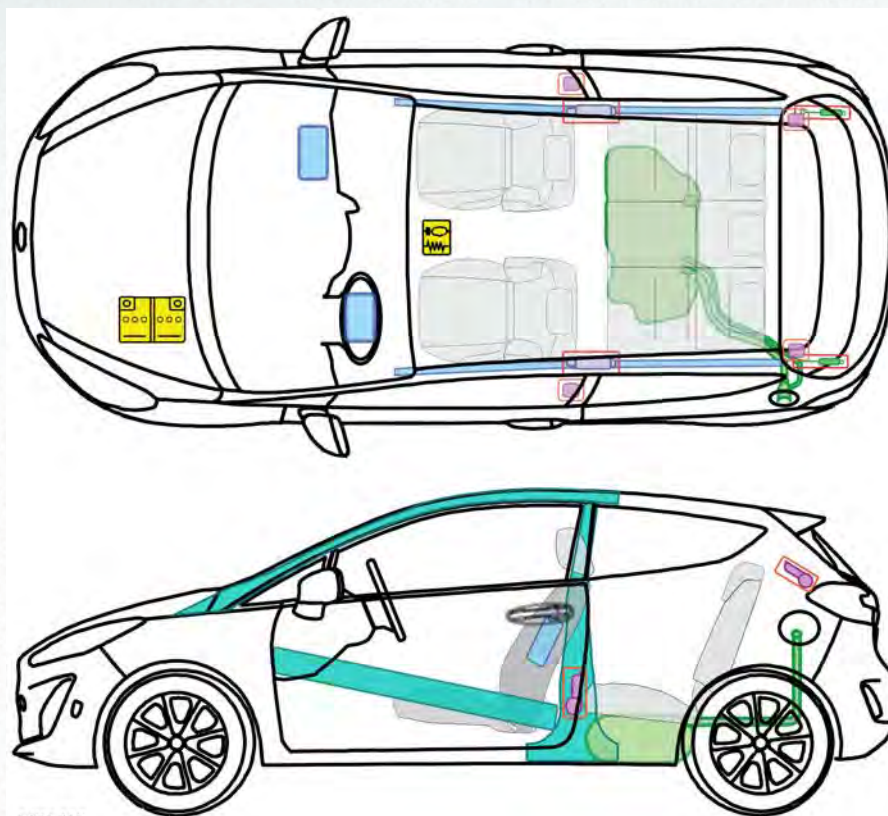

E255450

### Epígrafe

F

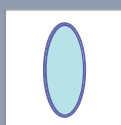

Airbag

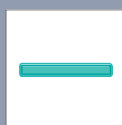

Refuerzos estructurales



Unidad de control



Sistema de protección de los peatones

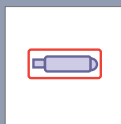

Generador de gas



Protección antivuelco activa

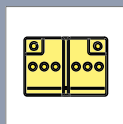

Batería

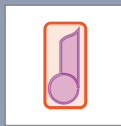

Tensor del cinturón de seguridad

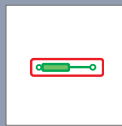

Dispositivo llenado de gas

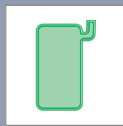

Depósito de combustible

(Fecha De Publicacion: : 05/2017)



# FORD SERVICE

Tarjetas de rescate

## FORD Fiesta - LPG

3 puertas

06/2008 – 04/2017

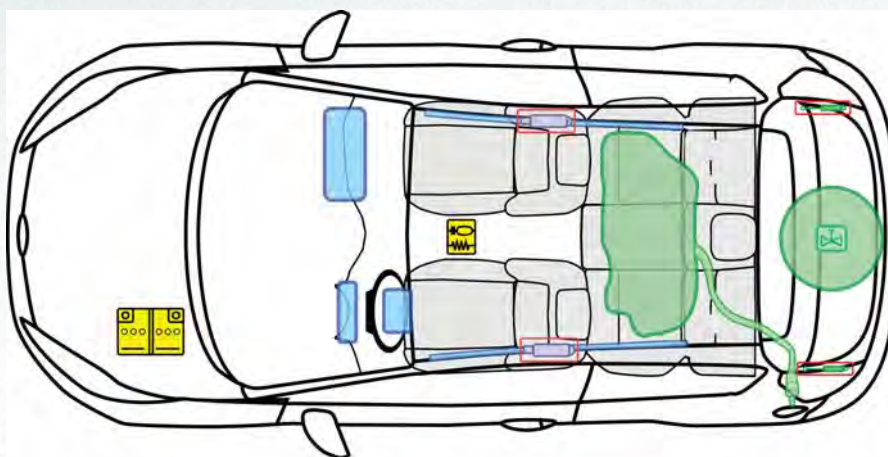

**LPG**

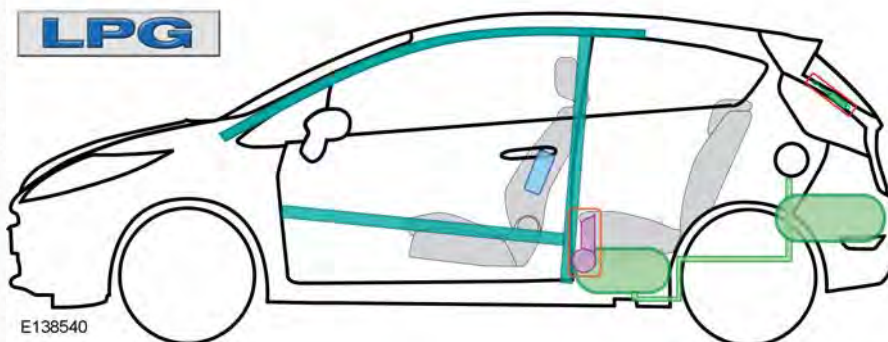

E138540

### Epígrafe

**F**

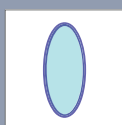

Airbag

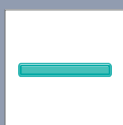

Refuerzos estructurales



Unidad de control



Sistema de protección de los peatones

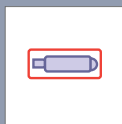

Generador de gas



Protección antivuelco activa

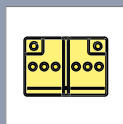

Batería



Depósito de gas

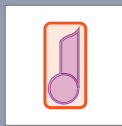

Tensor del cinturón de seguridad

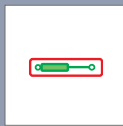

Dispositivo llenado de gas

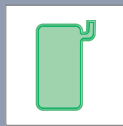

Depósito de combustible

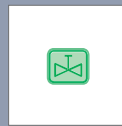

Válvula de seguridad

(Fecha De Publicacion: : 03/2011)



# FORD SERVICE

Tarjetas de rescate

## FORD Fiesta

5 puertas

11/2001 – 09/2008

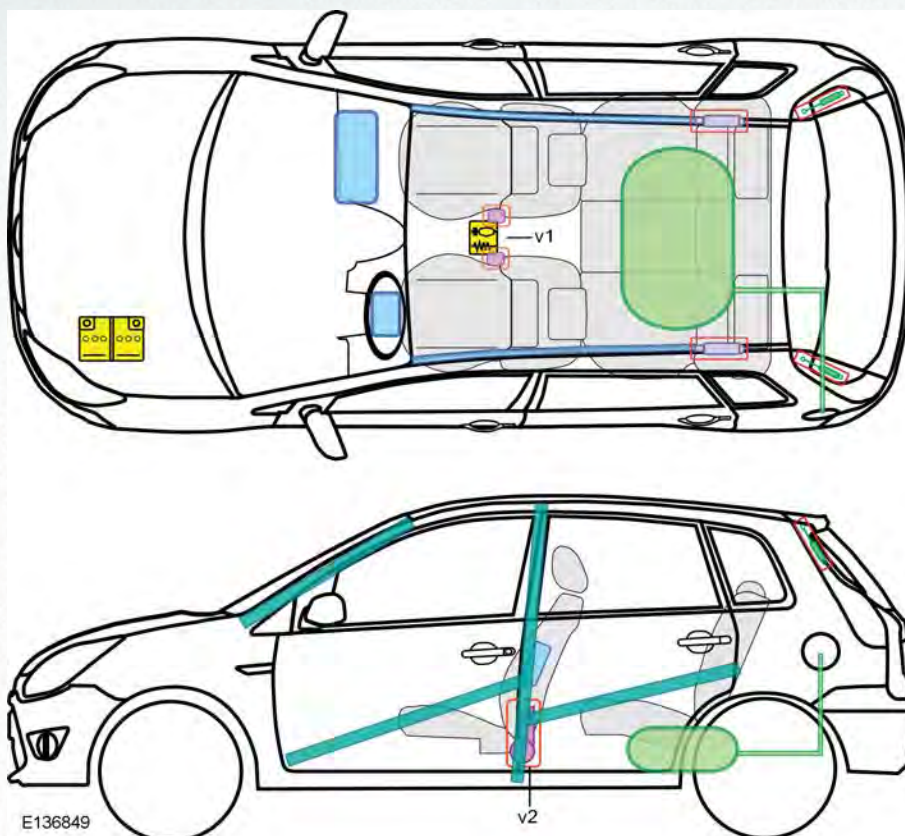

E136849

### Epígrafe

F

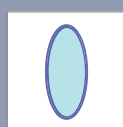

Airbag

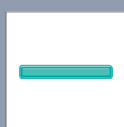

Refuerzos estructurales



Unidad de control



Sistema de protección de los peatones



Generador de gas

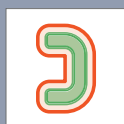

Protección antivuelco activa

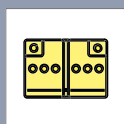

Batería

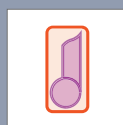

Tensor del cinturón de seguridad

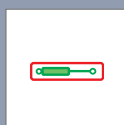

Dispositivo llenado de gas



Depósito de combustible

(Fecha De Publicacion: : 09/2011)





# FORD SERVICE

Tarjetas de rescate

## FORD Fiesta

5 puertas

06/2008 – 04/2017

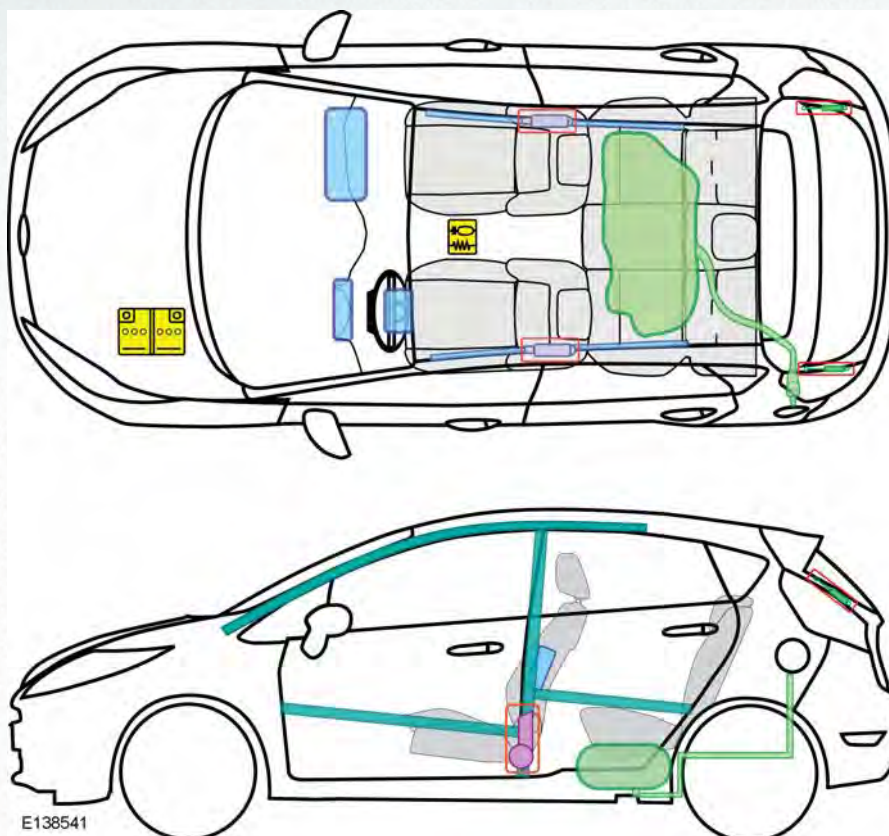

E138541

### Epígrafe

F

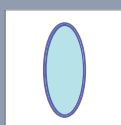

Airbag

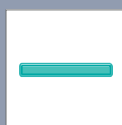

Refuerzos estructurales



Unidad de control



Sistema de protección de los peatones



Generador de gas



Protección antivuelco activa

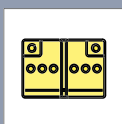

Batería

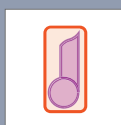

Tensor del cinturón de seguridad

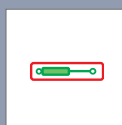

Dispositivo llenado de gas



Depósito de combustible

(Fecha De Publicacion: : 07/2013)



# FORD SERVICE

Tarjetas de rescate

## FORD Fiesta

5 puertas

04/2017 - >

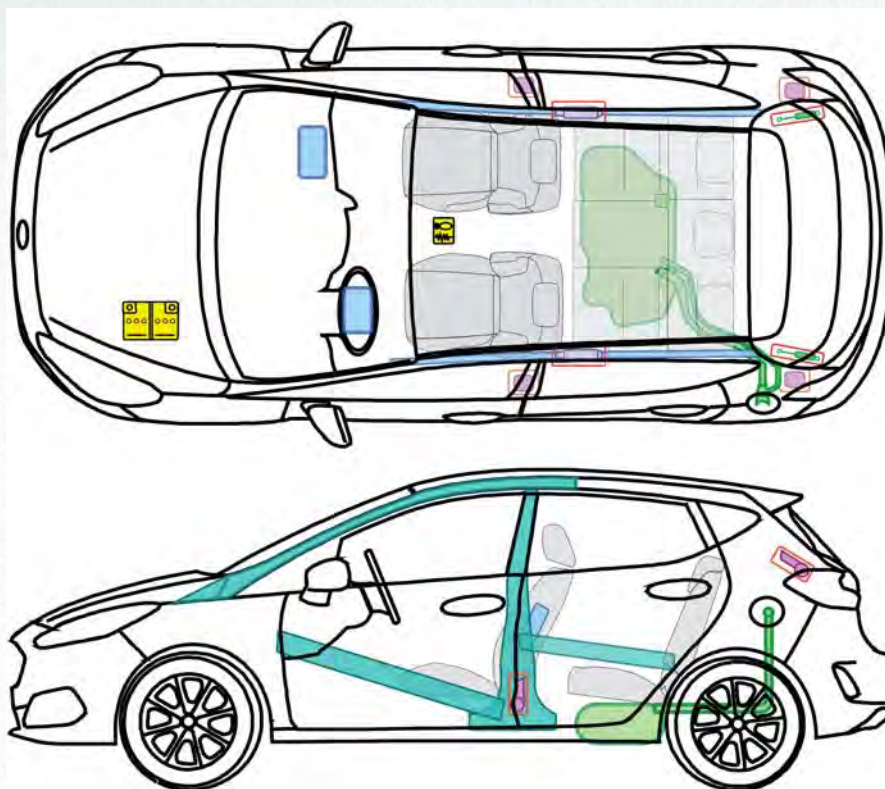

E255448

### Epígrafe

F

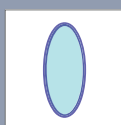

Airbag

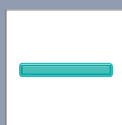

Refuerzos estructurales



Unidad de control



Sistema de protección de los peatones



Generador de gas



Protección antivuelco activa

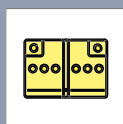

Batería

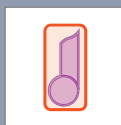

Tensor del cinturón de seguridad

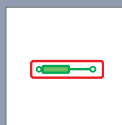

Dispositivo llenado de gas



Depósito de combustible

(Fecha De Publicacion: : 05/2017)



# FORD SERVICE

Tarjetas de rescate

## FORD Fiesta - LPG

5 puertas

06/2008 – 04/2017

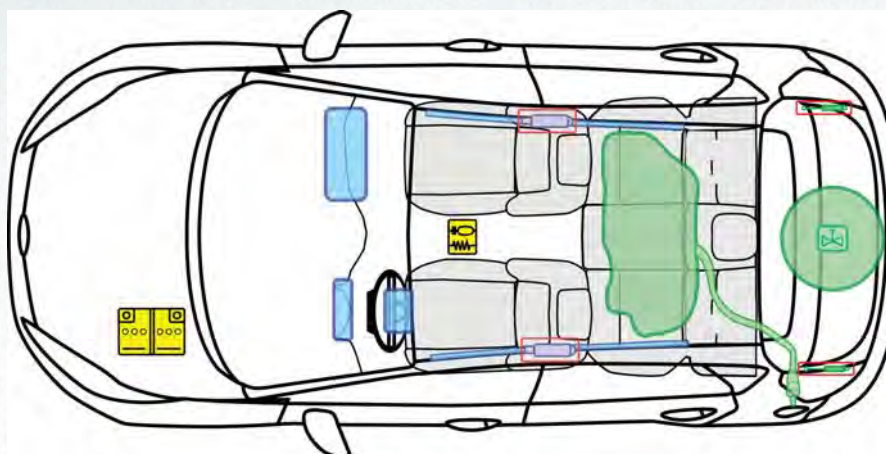



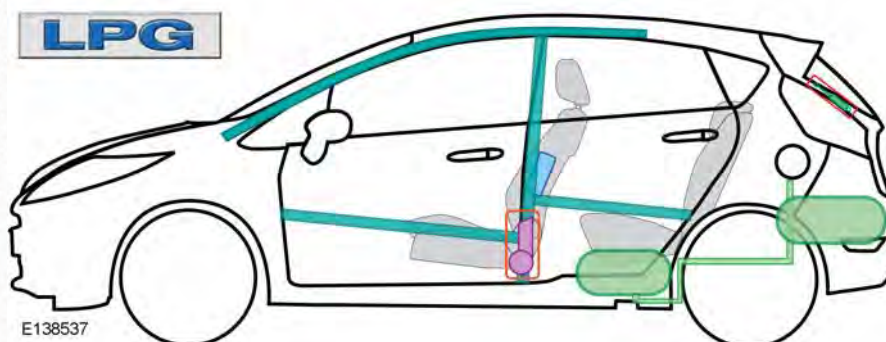







**LPG**

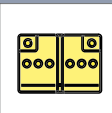

E138537

### Epígrafe

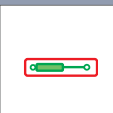
**F**

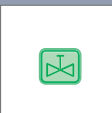
	Airbag		Refuerzos estructurales		Unidad de control		Sistema de protección de los peatones
	Generador de gas		Protección antivuelco activa		Batería		Depósito de gas
	Tensor del cinturón de seguridad		Dispositivo llenado de gas		Depósito de combustible		Válvula de seguridad

(Fecha De Publicacion: : 03/2011)



# FORD SERVICE

Tarjetas de rescate

## FORD Fiesta mHEV

1,0l EcoBoost (92kW/125CV) (B7), 1,0l EcoBoost (114kW/155CV) (BZ), 3 puertas

04/2017 – >

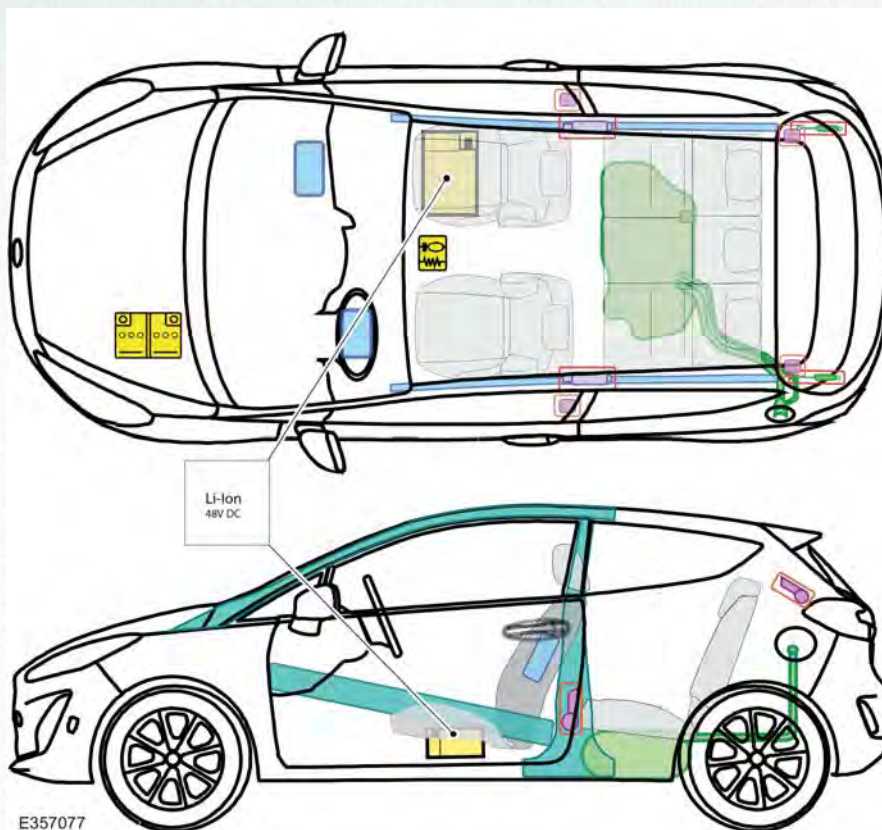

### Epígrafe

F

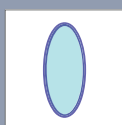

Airbag

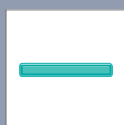

Refuerzos estructurales



Unidad de control



Sistema de protección de los peatones



Generador de gas



Protección antivuelco activa

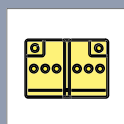

Batería

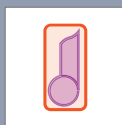

Tensor del cinturón de seguridad

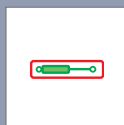

Dispositivo llenado de gas



Depósito de combustible

(Fecha De Publicacion: : 04/2021)



# FORD SERVICE

Tarjetas de rescate

## FORD Fiesta mHEV

1,0l EcoBoost (92kW/125CV) (B7), 1,0l EcoBoost (114kW/155CV) (BZ), 5 puertas

04/2017 – >

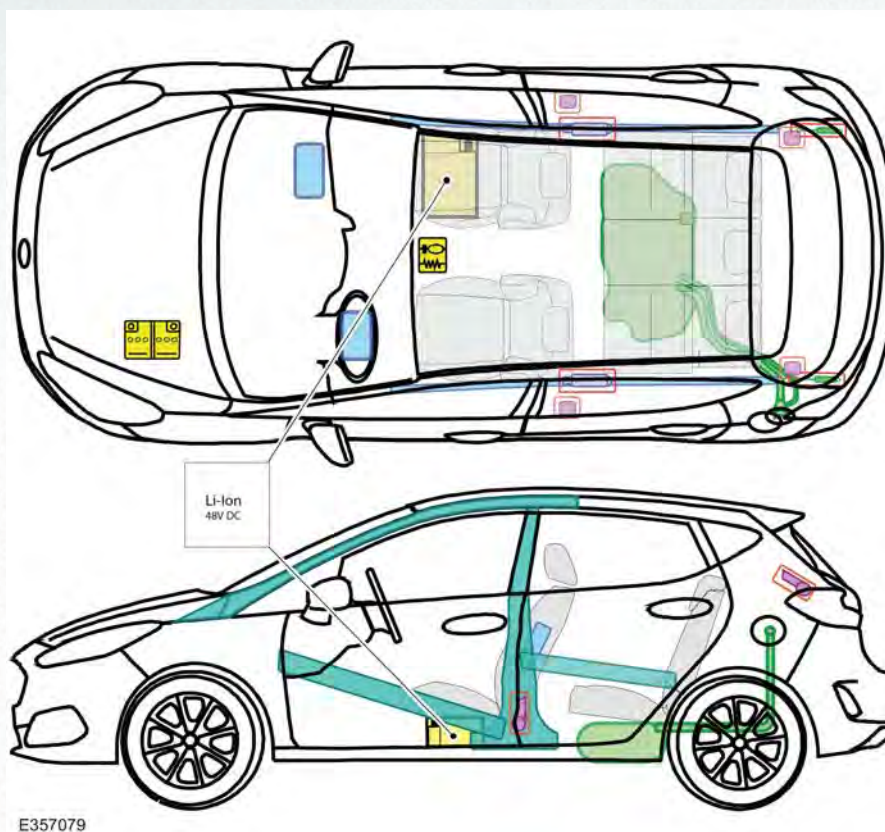

E357079

### Epígrafe

F

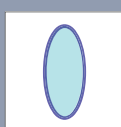

Airbag

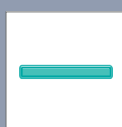

Refuerzos estructurales



Unidad de control



Sistema de protección de los peatones



Generador de gas



Protección antivuelco activa

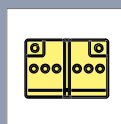

Batería

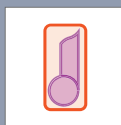

Tensor del cinturón de seguridad

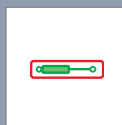

Dispositivo llenado de gas



Depósito de combustible

(Fecha De Publicacion: : 04/2021)



# FORD SERVICE

Tarjetas de rescate

## FORD Focus

3 puertas

07/2004 – 08/2007

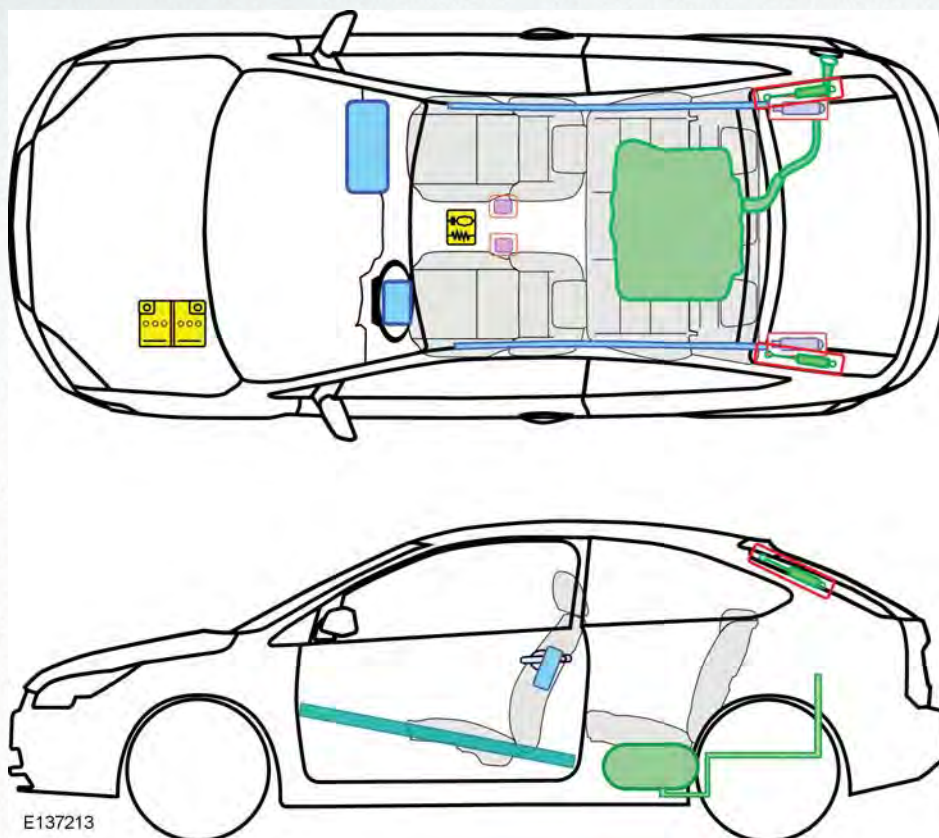

### Epígrafe

F

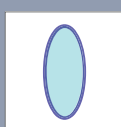

Airbag

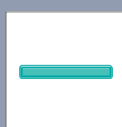

Refuerzos estructurales



Unidad de control



Sistema de protección de los peatones



Generador de gas



Protección antivuelco activa

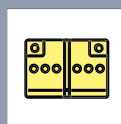

Batería

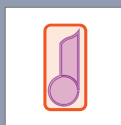

Tensor del cinturón de seguridad

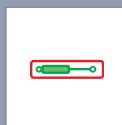

Dispositivo llenado de gas



Depósito de combustible

(Fecha De Publicacion: : 03/2011)



# FORD SERVICE

Tarjetas de rescate

## FORD Focus

3 puertas

08/2007 – 03/2011

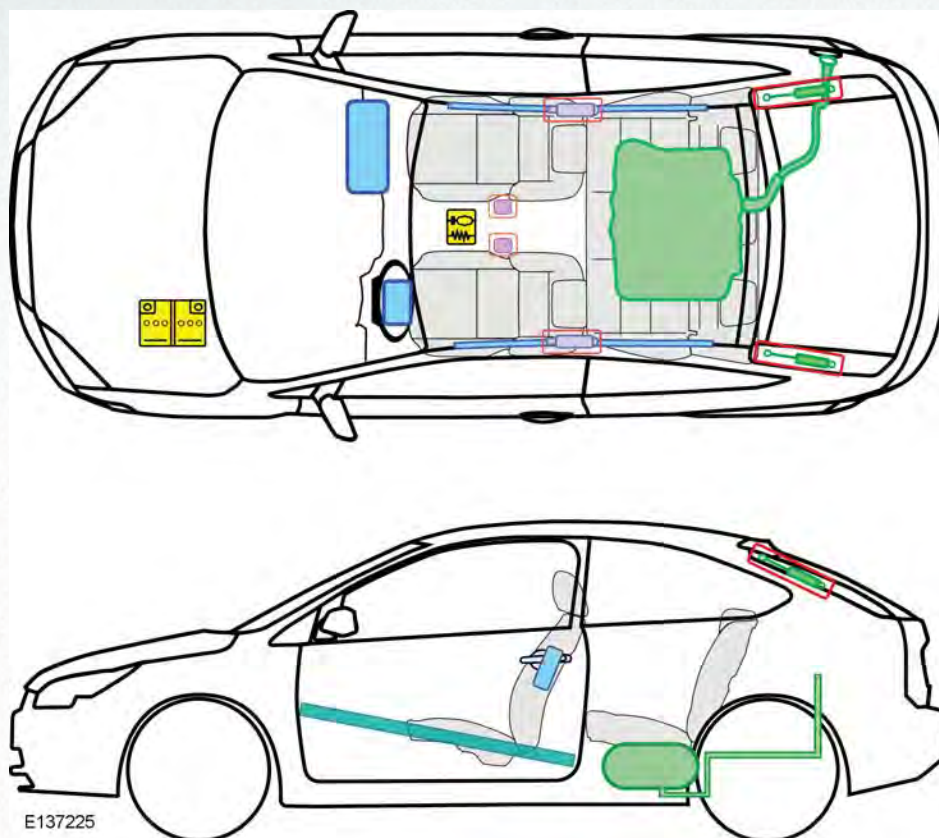

### Epígrafe

F

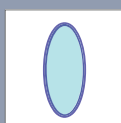

Airbag

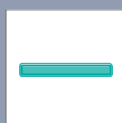

Refuerzos estructurales



Unidad de control



Sistema de protección de los peatones



Generador de gas



Protección antivuelco activa

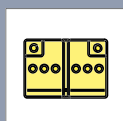

Batería

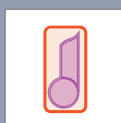

Tensor del cinturón de seguridad

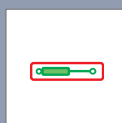

Dispositivo llenado de gas



Depósito de combustible

(Fecha De Publicacion: : 03/2011)



# FORD SERVICE

Tarjetas de rescate

## FORD Focus

3 puertas

08/1998 – 12/2004

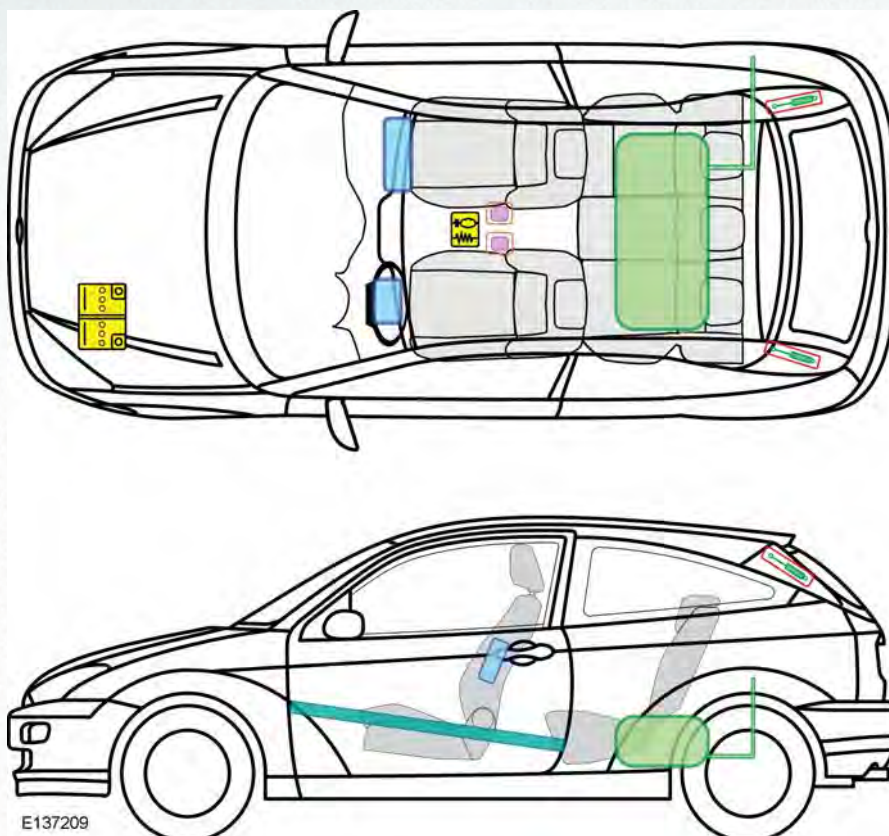

### Epígrafe

F

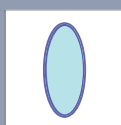

Airbag

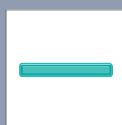

Refuerzos estructurales



Unidad de control



Sistema de protección de los peatones



Generador de gas



Protección antivuelco activa

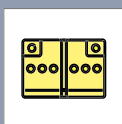

Batería

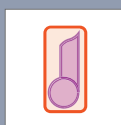

Tensor del cinturón de seguridad

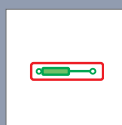

Dispositivo llenado de gas



Depósito de combustible

(Fecha De Publicacion: : 03/2011)





# FORD SERVICE

Tarjetas de rescate

## FORD Focus - LPG

3 puertas

08/2007 – 03/2011



E137224

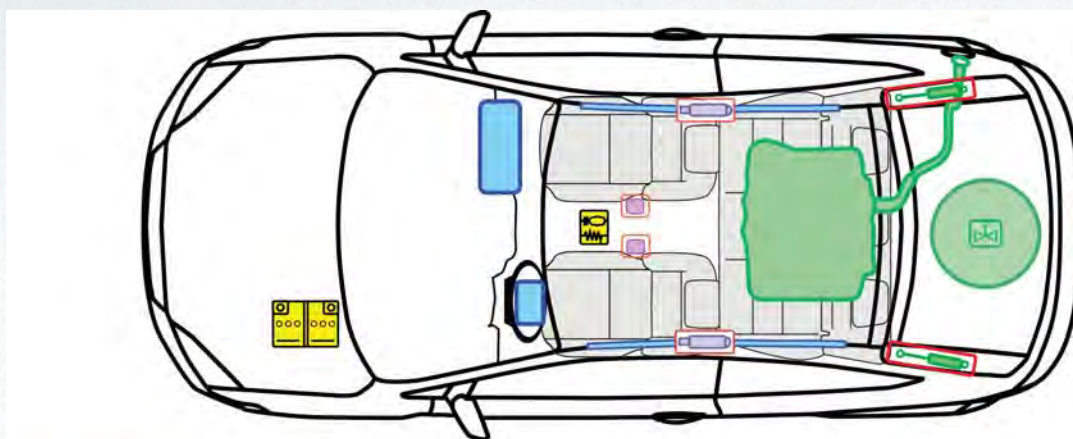

**LPG**

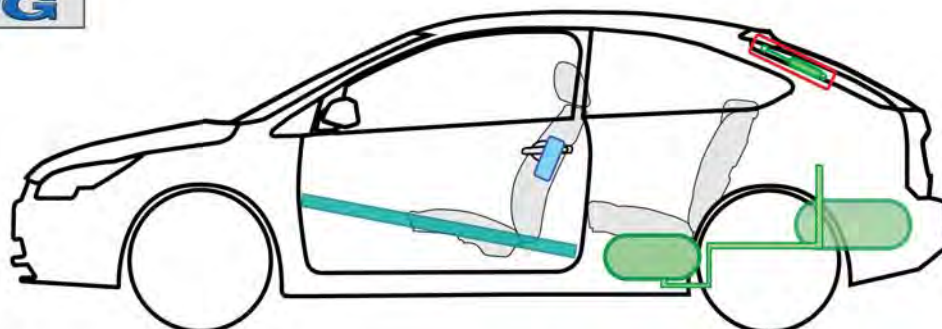

E137493

Epígrafe

**F**

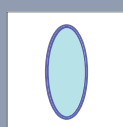

Airbag

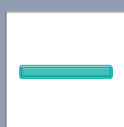

Refuerzos estructurales



Unidad de control



Sistema de protección de los peatones



Generador de gas



Protección antivuelco activa

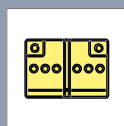

Batería



Depósito de gas

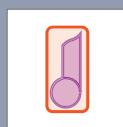

Tensor del cinturón de seguridad

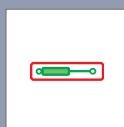

Dispositivo llenado de gas



Depósito de combustible



Válvula de seguridad

(Fecha De Publicacion: : 01/2011)



# FORD SERVICE

Tarjetas de rescate

## FORD Focus - LPG

3 puertas

07/2004 – 08/2007

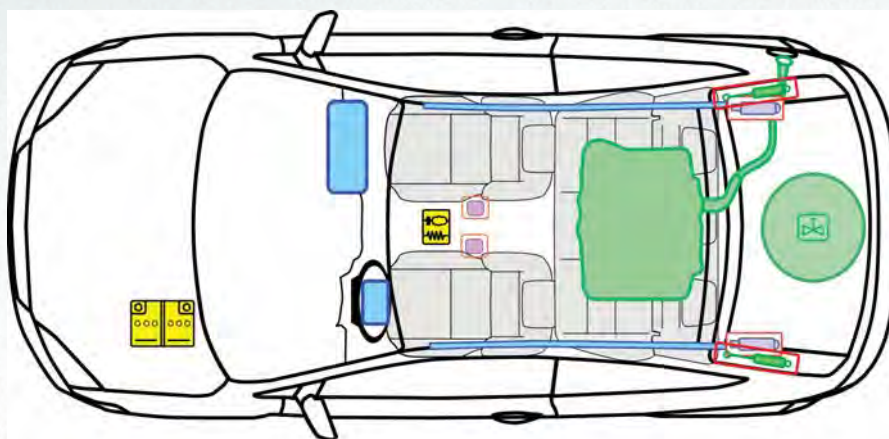

**LPG**

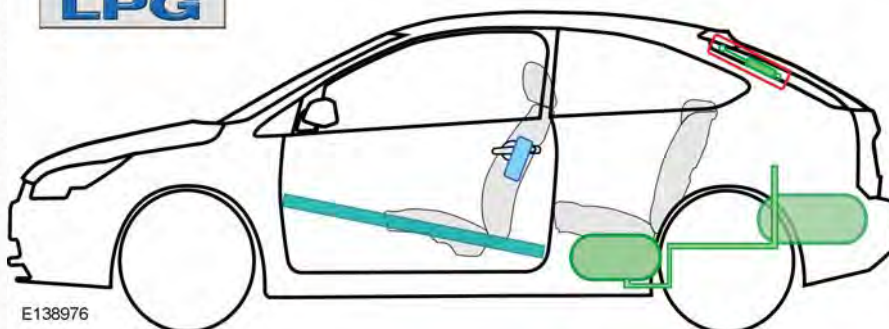

E138976

### Epígrafe

**F**

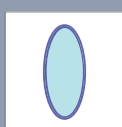

Airbag

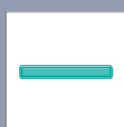

Refuerzos estructurales



Unidad de control



Sistema de protección de los peatones

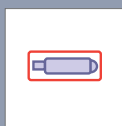

Generador de gas



Protección antivuelco activa

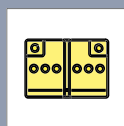

Batería



Depósito de gas

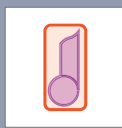

Tensor del cinturón de seguridad

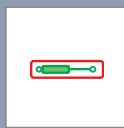

Dispositivo llenado de gas

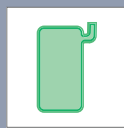

Depósito de combustible



Válvula de seguridad

(Fecha De Publicacion: : 03/2011)



# FORD SERVICE

Tarjetas de rescate

## FORD Focus - CNG

3 puertas

07/2004 – 08/2007

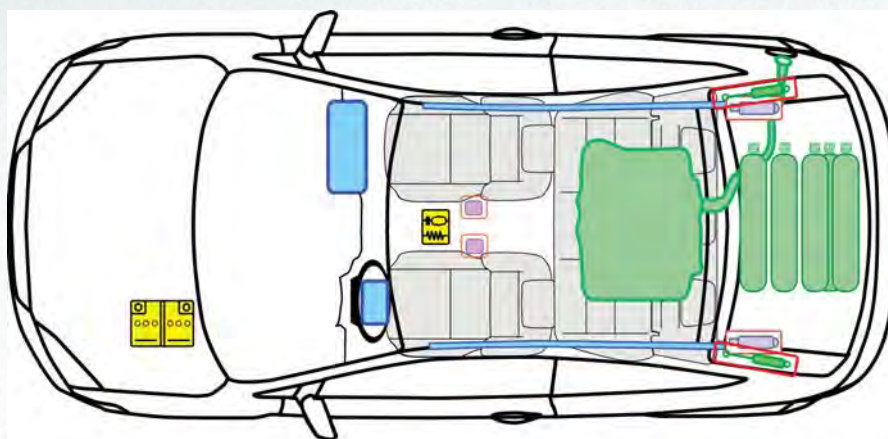

**CNG**

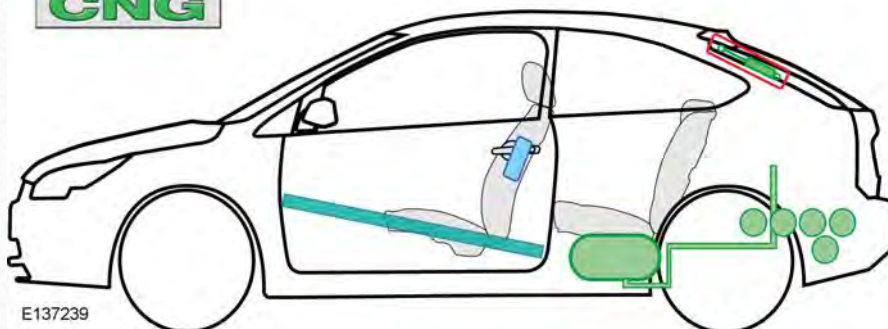

E137239

### Epígrafe

**F**

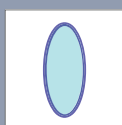

Airbag

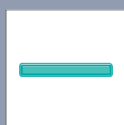

Refuerzos estructurales



Unidad de control



Sistema de protección de los peatones

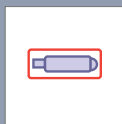

Generador de gas



Protección antivuelco activa

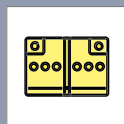

Batería



Depósito de gas

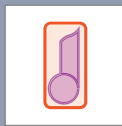

Tensor del cinturón de seguridad

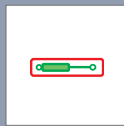

Dispositivo llenado de gas



Depósito de combustible

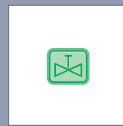

Válvula de seguridad

(Fecha De Publicacion: : 03/2011)



# FORD SERVICE

Tarjetas de rescate

## FORD Focus - CNG

3 puertas

08/2007 – 03/2011



E137224

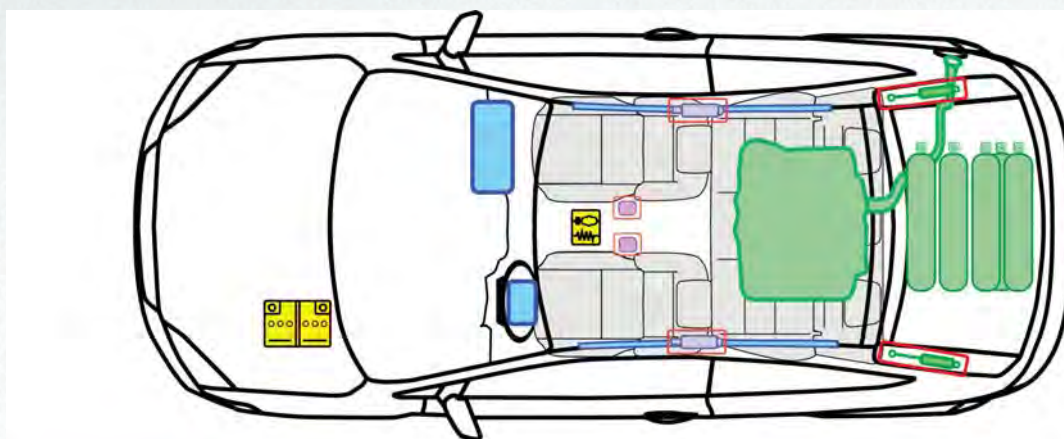

**CNG**

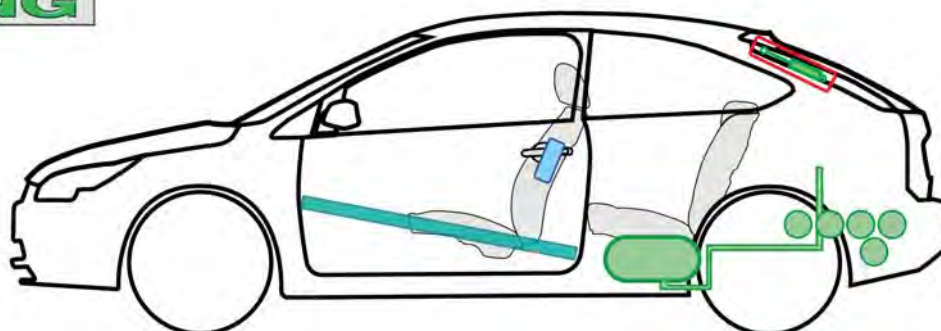

E137463

Epígrafe

F

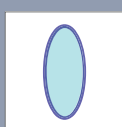

Airbag



Refuerzos estructurales



Unidad de control



Sistema de protección de los peatones



Generador de gas



Protección antivuelco activa

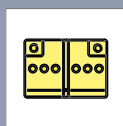

Batería



Depósito de gas

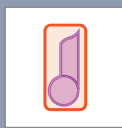

Tensor del cinturón de seguridad

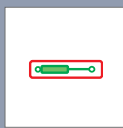

Dispositivo llenado de gas



Depósito de combustible

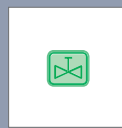

Válvula de seguridad

(Fecha De Publicacion: : 01/2011)



# FORD SERVICE

Tarjetas de rescate

## FORD Focus

4 puertas

07/2004 – 08/2007



E137219

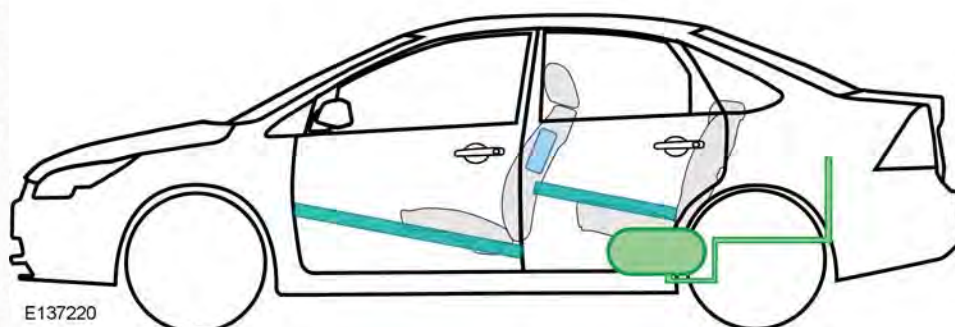
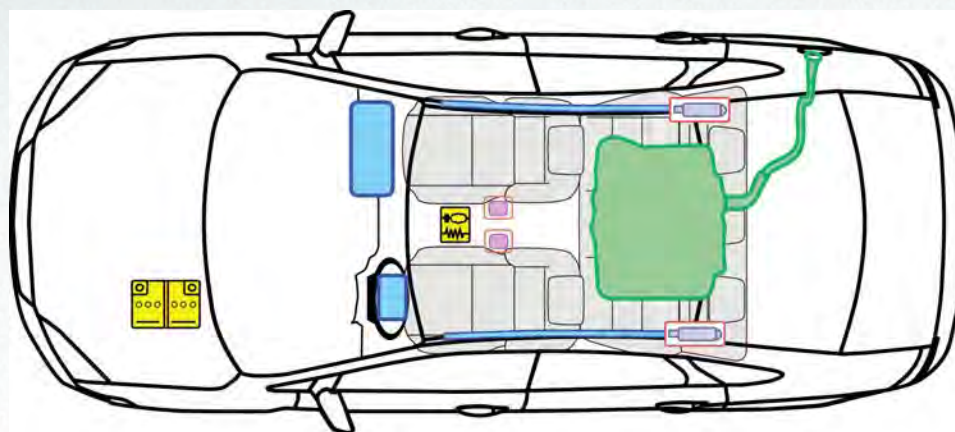

E137220

### Epígrafe

F

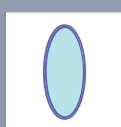

Airbag

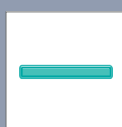

Refuerzos estructurales



Unidad de control



Sistema de protección de los peatones



Generador de gas



Protección antivuelco activa

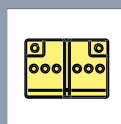

Batería

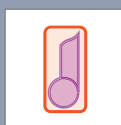

Tensor del cinturón de seguridad

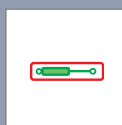

Dispositivo llenado de gas



Depósito de combustible

(Fecha De Publicacion: : 03/2011)



# FORD SERVICE

Tarjetas de rescate

## FORD Focus

4 puertas

08/1998 – 12/2004

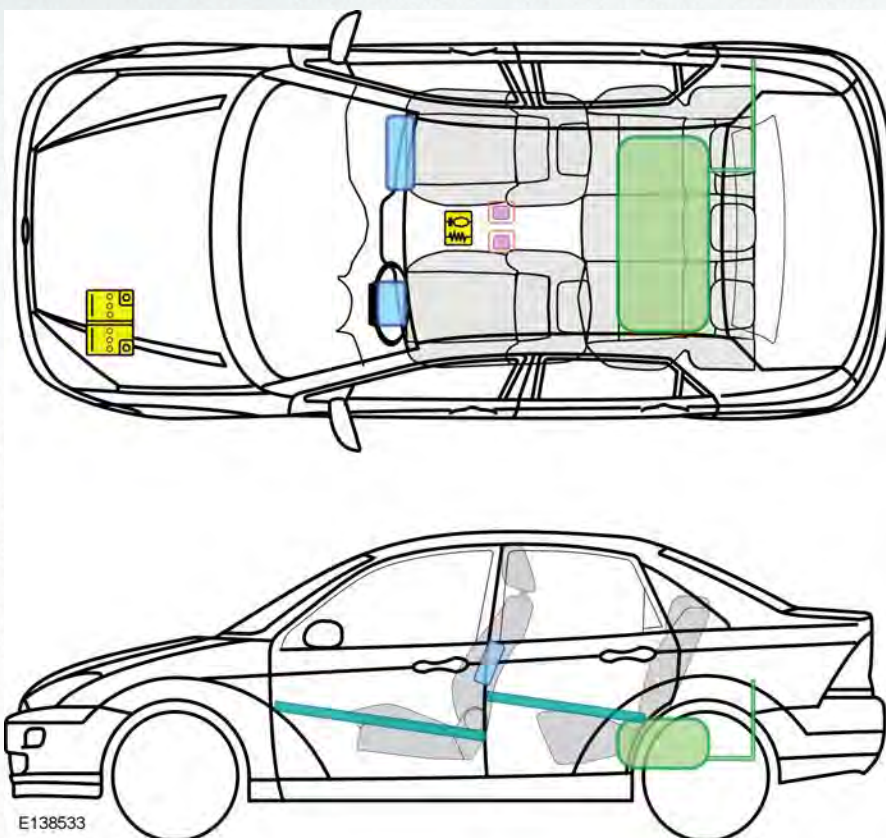

Epígrafe

F

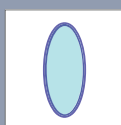

Airbag

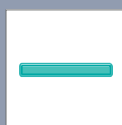

Refuerzos estructurales



Unidad de control



Sistema de protección de los peatones

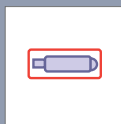

Generador de gas



Protección antivuelco activa

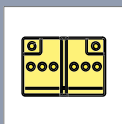

Batería

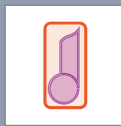

Tensor del cinturón de seguridad

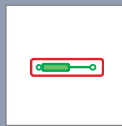

Dispositivo llenado de gas

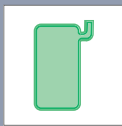

Depósito de combustible

(Fecha De Publicacion: : 03/2011)

# FORD SERVICE

Tarjetas de rescate

## FORD Focus

4 puertas

08/2007 – 03/2011

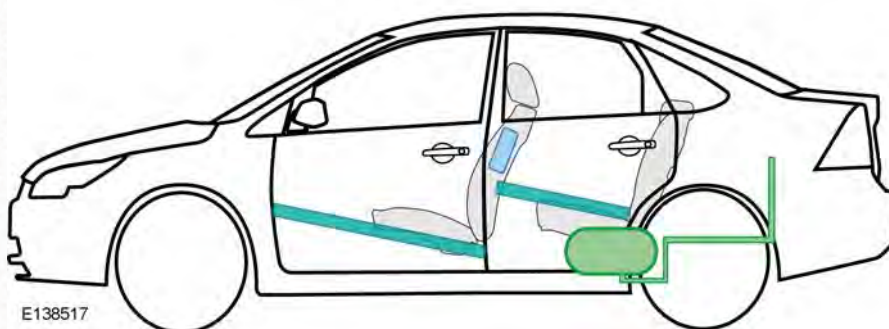
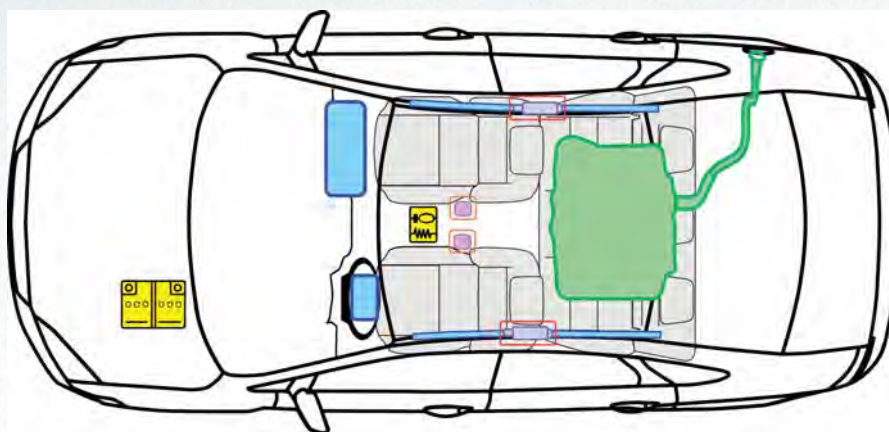

E138517

### Epígrafe

F

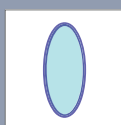

Airbag

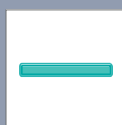

Refuerzos estructurales



Unidad de control



Sistema de protección de los peatones



Generador de gas



Protección antivuelco activa

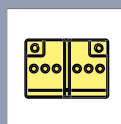

Batería

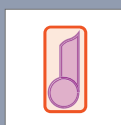

Tensor del cinturón de seguridad

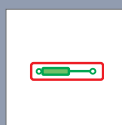

Dispositivo llenado de gas



Depósito de combustible

(Fecha De Publicacion: : 03/2011)



# FORD SERVICE

Tarjetas de rescate

## FORD Focus

4 puertas

03/2011 – 09/2014

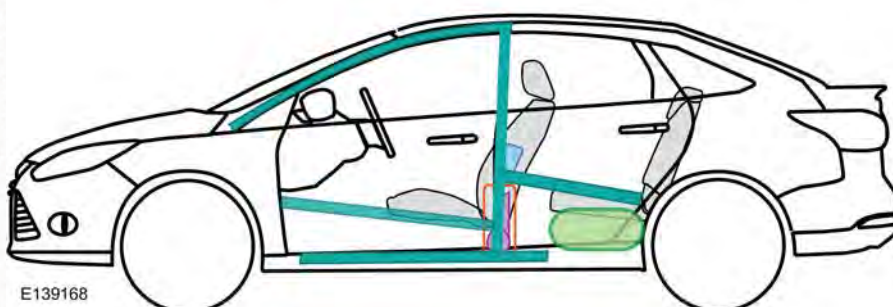
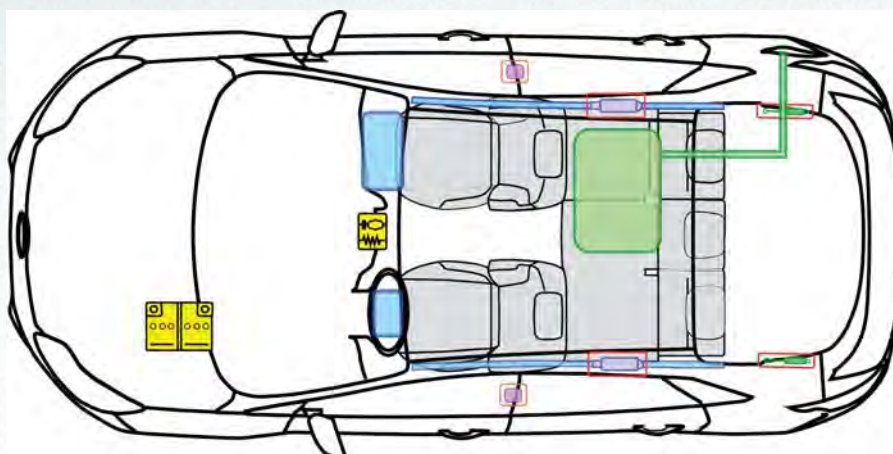

E139168

### Epígrafe

F

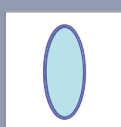

Airbag



Refuerzos estructurales



Unidad de control



Sistema de protección de los peatones



Generador de gas



Protección antivuelco activa

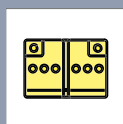

Batería

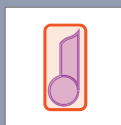

Tensor del cinturón de seguridad

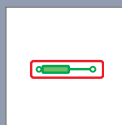

Dispositivo llenado de gas

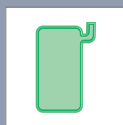

Depósito de combustible

(Fecha De Publicacion: : 10/2012)





# FORD SERVICE

Tarjetas de rescate

## FORD Focus

4 puertas

09/2014 – 04/2018

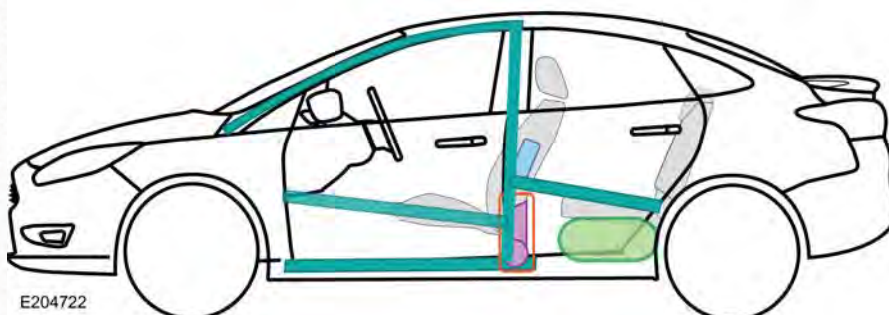
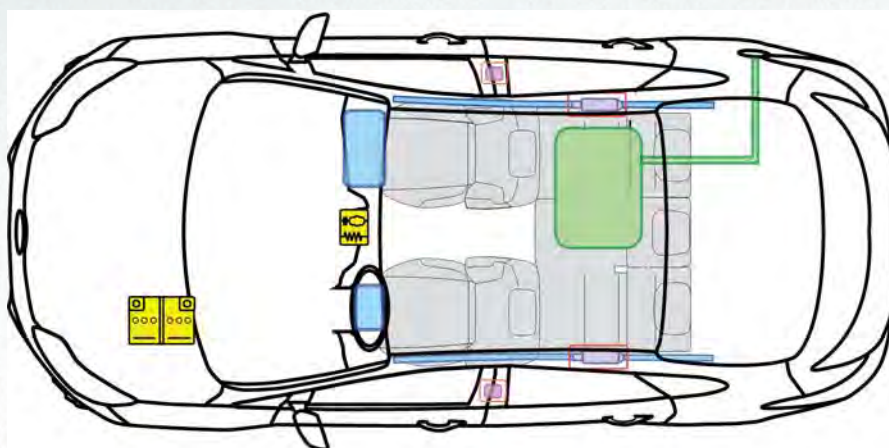

E204722

### Epígrafe

F

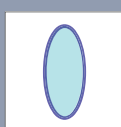

Airbag

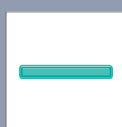

Refuerzos estructurales



Unidad de control



Sistema de protección de los peatones



Generador de gas



Protección antivuelco activa

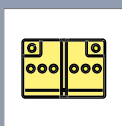

Batería

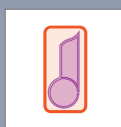

Tensor del cinturón de seguridad

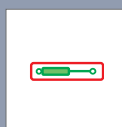

Dispositivo llenado de gas



Depósito de combustible

(Fecha De Publicacion: : 12/2014)



# FORD SERVICE

Tarjetas de rescate

## FORD Focus

4 puertas

04/2018 – >

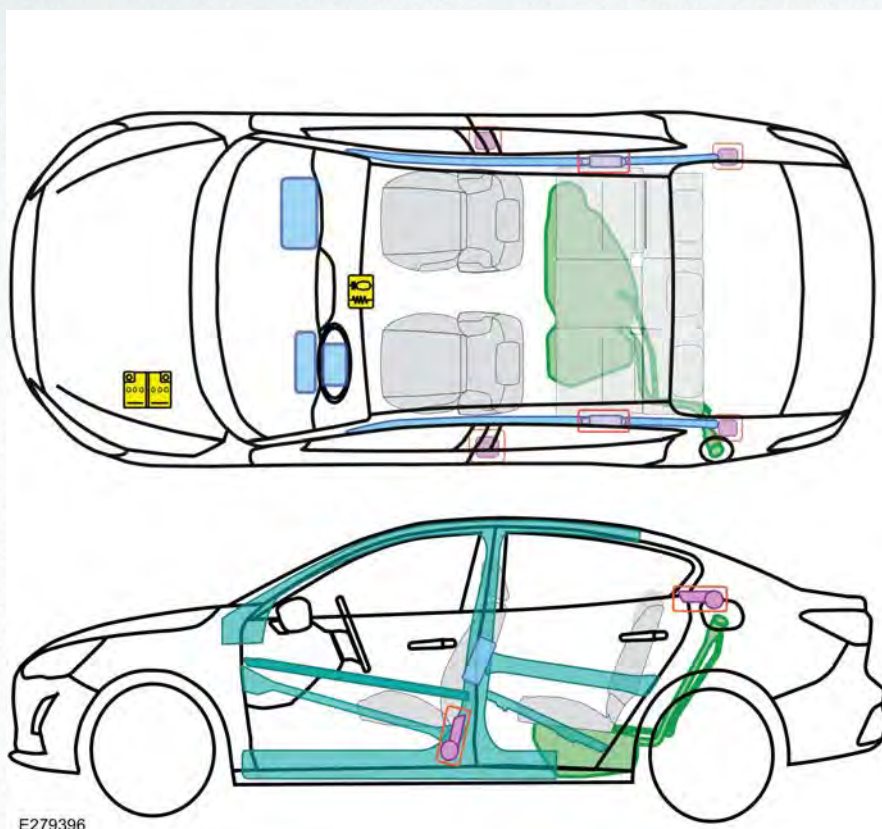

E279396

### Epígrafe

F

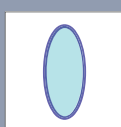

Airbag

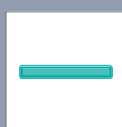

Refuerzos estructurales



Unidad de control



Sistema de protección de los peatones



Generador de gas



Protección antivuelco activa

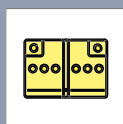

Batería

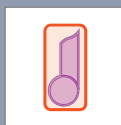

Tensor del cinturón de seguridad

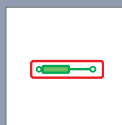

Dispositivo llenado de gas



Depósito de combustible

(Fecha De Publicacion: : 01/2019)



# FORD SERVICE

Tarjetas de rescate

## FORD Focus

5 puertas

08/2007 – 03/2011



E137240

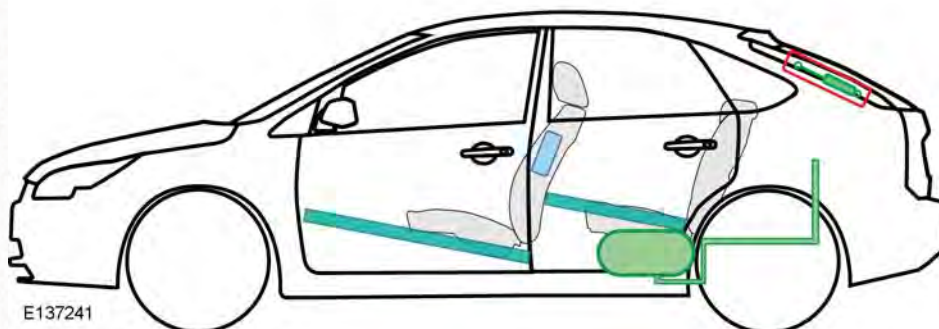
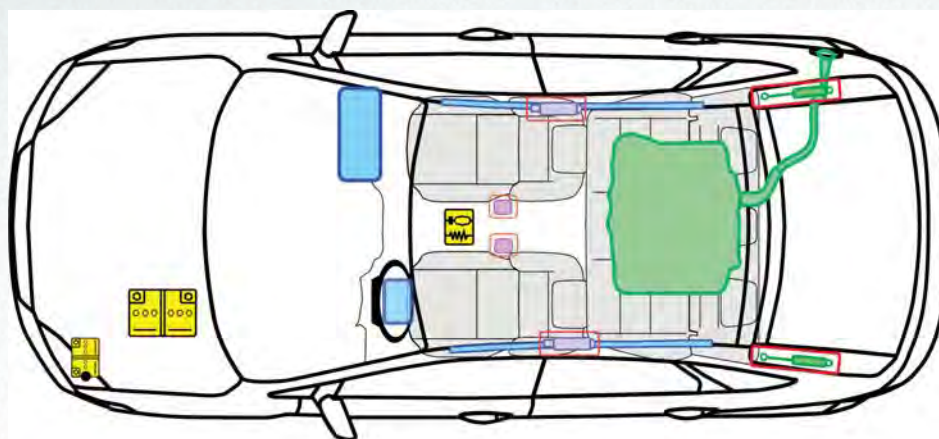

E137241

### Epígrafe

F

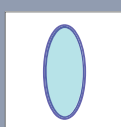

Airbag

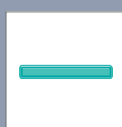

Refuerzos estructurales



Unidad de control



Sistema de protección de los peatones



Generador de gas



Protección antivuelco activa

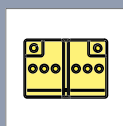

Batería

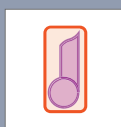

Tensor del cinturón de seguridad

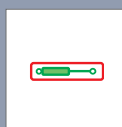

Dispositivo llenado de gas



Depósito de combustible

(Fecha De Publicacion: : 01/2011)



# FORD SERVICE

Tarjetas de rescate

## FORD Focus

5 puertas

08/1998 – 12/2004

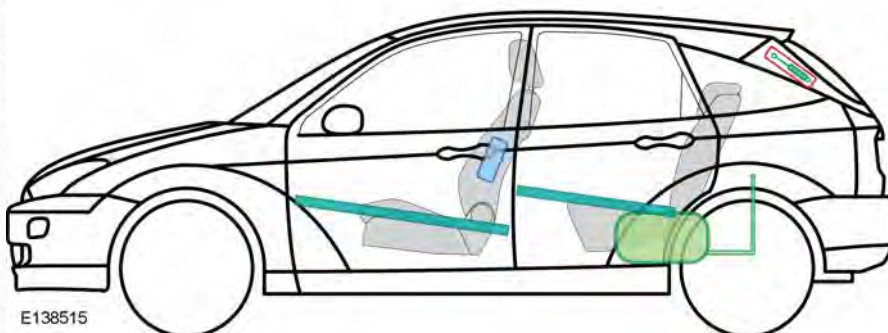
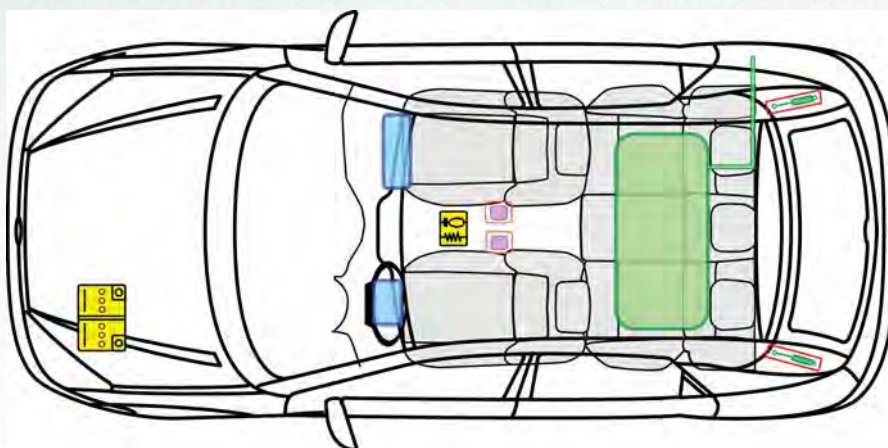

E138515

### Epígrafe

F

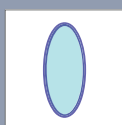

Airbag

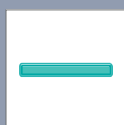

Refuerzos estructurales



Unidad de control



Sistema de protección de los peatones



Generador de gas



Protección antivuelco activa

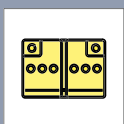

Batería

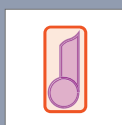

Tensor del cinturón de seguridad

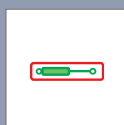

Dispositivo llenado de gas



Depósito de combustible

(Fecha De Publicacion: : 03/2011)



# FORD SERVICE

Tarjetas de rescate

## FORD Focus

5 puertas

03/2011 – 09/2014

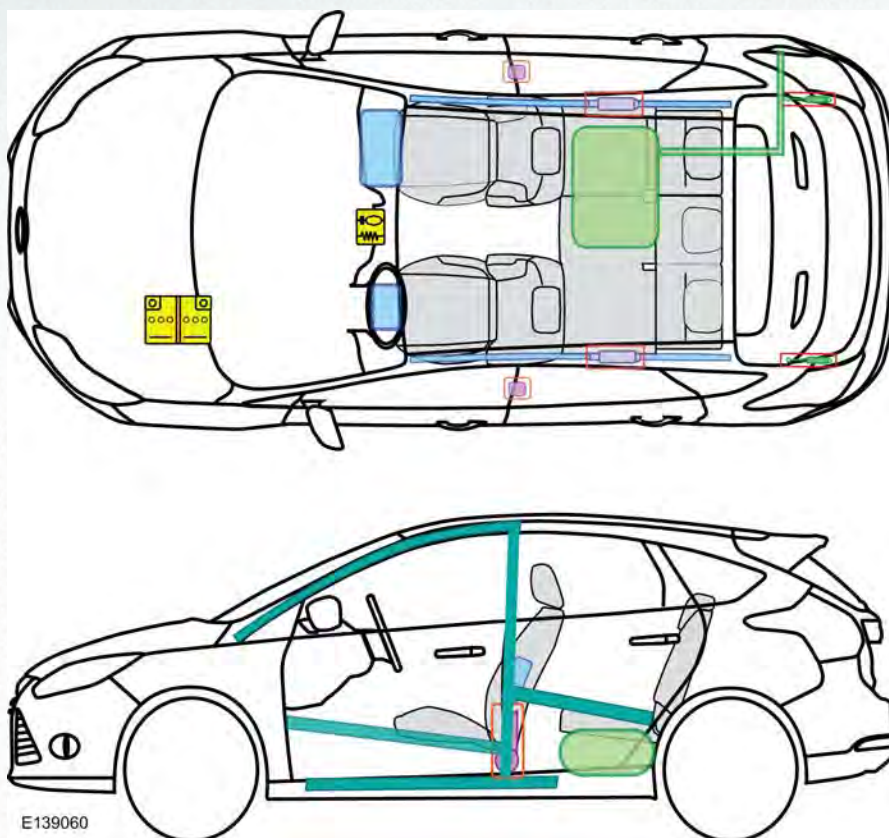

E139060

### Epígrafe

F

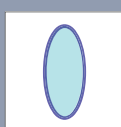

Airbag

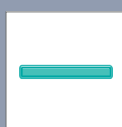

Refuerzos estructurales



Unidad de control



Sistema de protección de los peatones

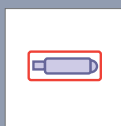

Generador de gas



Protección antivuelco activa

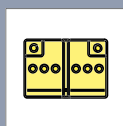

Batería

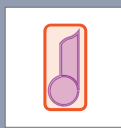

Tensor del cinturón de seguridad

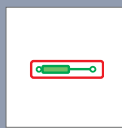

Dispositivo llenado de gas



Depósito de combustible

(Fecha De Publicacion: : 10/2012)



# FORD SERVICE

Tarjetas de rescate

## FORD Focus

5 puertas

07/2004 – 08/2007

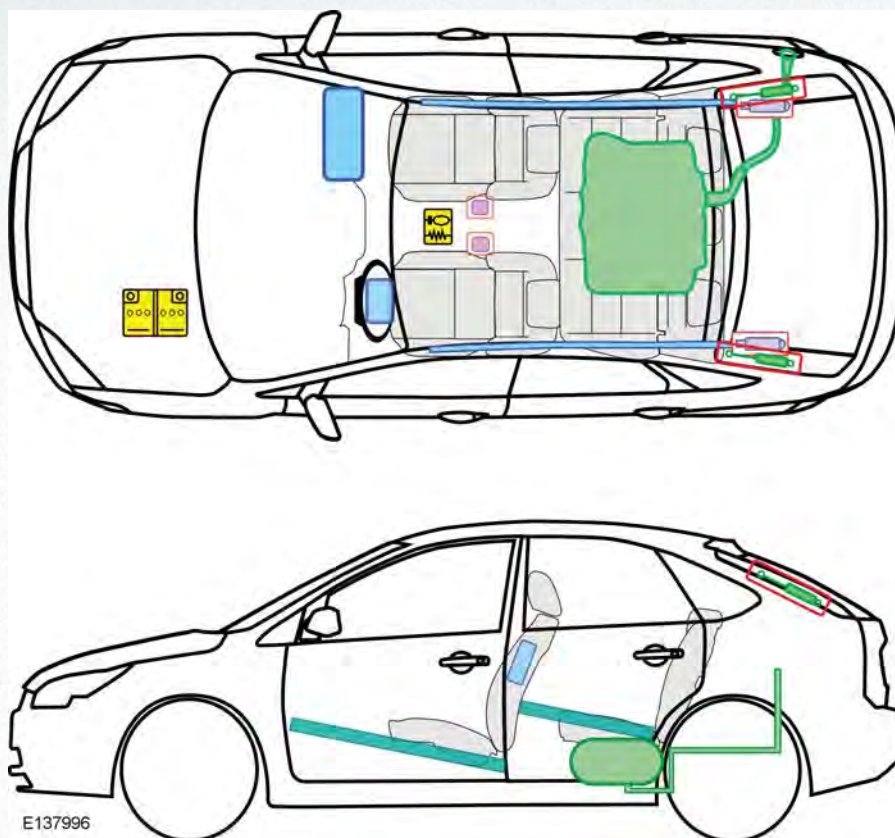

### Epígrafe

F

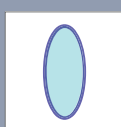

Airbag

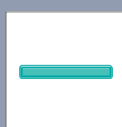

Refuerzos estructurales



Unidad de control



Sistema de protección de los peatones



Generador de gas



Protección antivuelco activa

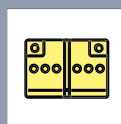

Batería

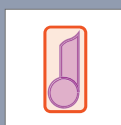

Tensor del cinturón de seguridad

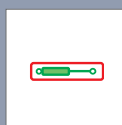

Dispositivo llenado de gas



Depósito de combustible

(Fecha De Publicacion: : 03/2011)



# FORD SERVICE

Tarjetas de rescate

## FORD Focus

5 puertas

09/2014 – 04/2018

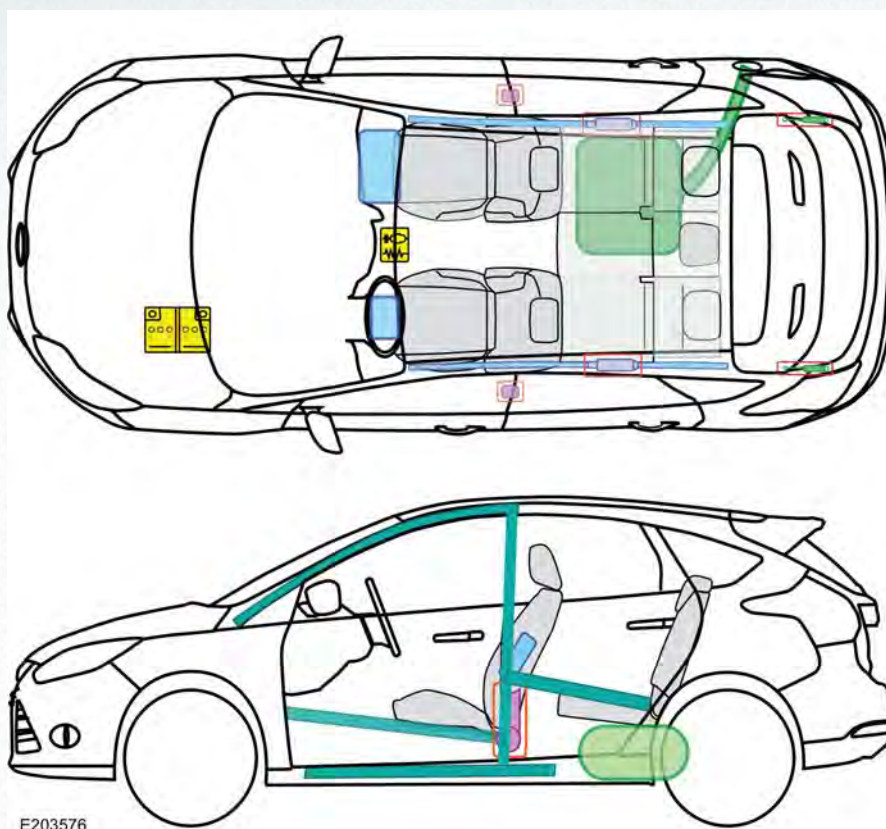

### Epígrafe

F

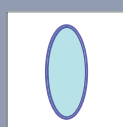

Airbag

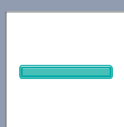

Refuerzos estructurales



Unidad de control



Sistema de protección de los peatones



Generador de gas

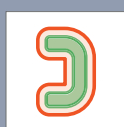

Protección antivuelco activa

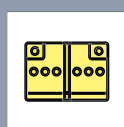

Batería

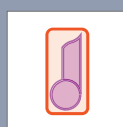

Tensor del cinturón de seguridad

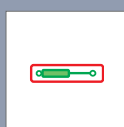

Dispositivo llenado de gas



Depósito de combustible

(Fecha De Publicacion: : 12/2018)



# FORD SERVICE

Tarjetas de rescate

## FORD Focus

5 puertas

04/2018 – >

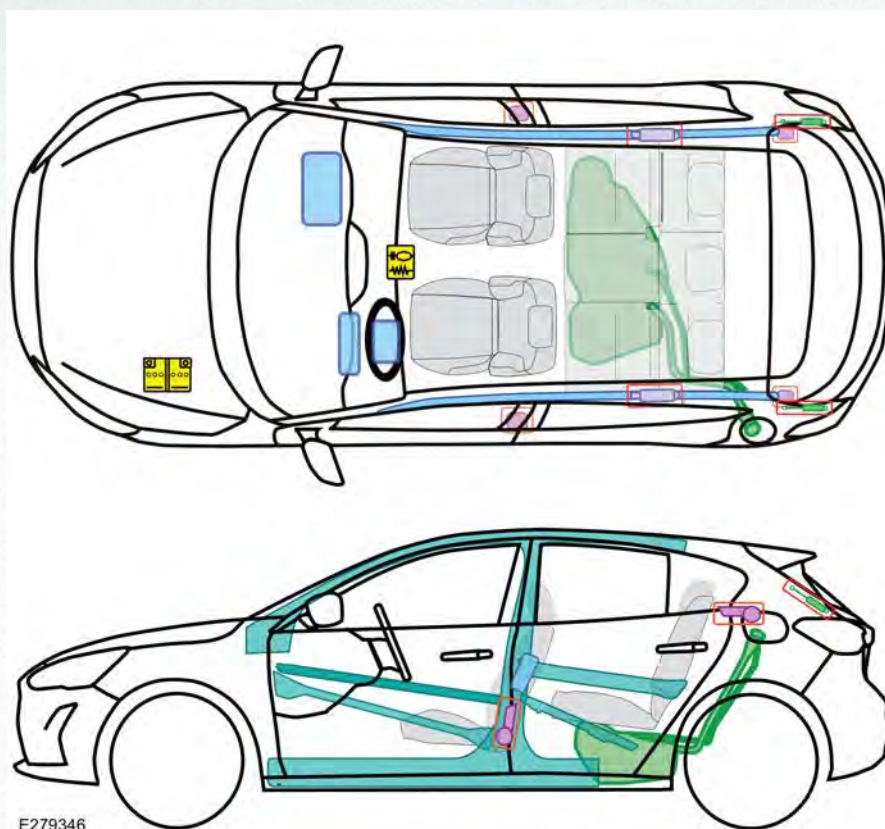

### Epígrafe

F

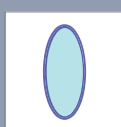

Airbag

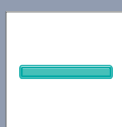

Refuerzos estructurales



Unidad de control



Sistema de protección de los peatones



Generador de gas



Protección antivuelco activa

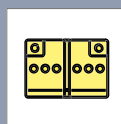

Batería

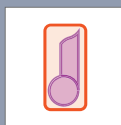

Tensor del cinturón de seguridad

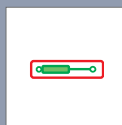

Dispositivo llenado de gas



Depósito de combustible

(Fecha De Publicacion: : 01/2019)





# FORD SERVICE

Tarjetas de rescate

## FORD Focus - LPG

5 puertas

08/2007 – 03/2011

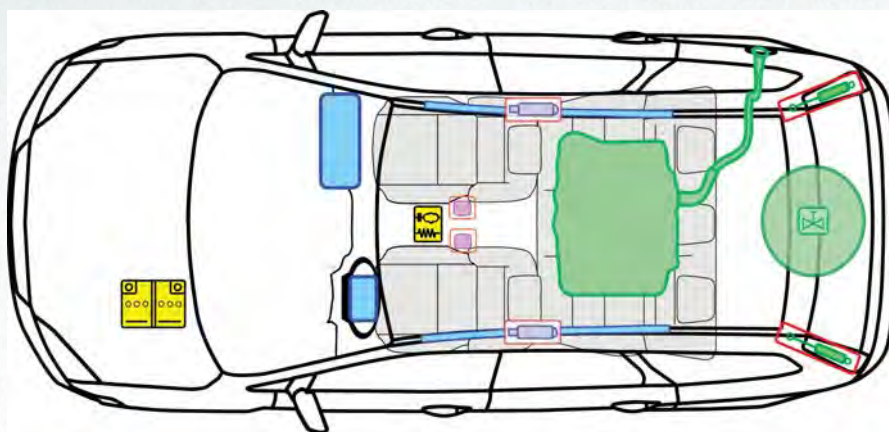

**LPG**

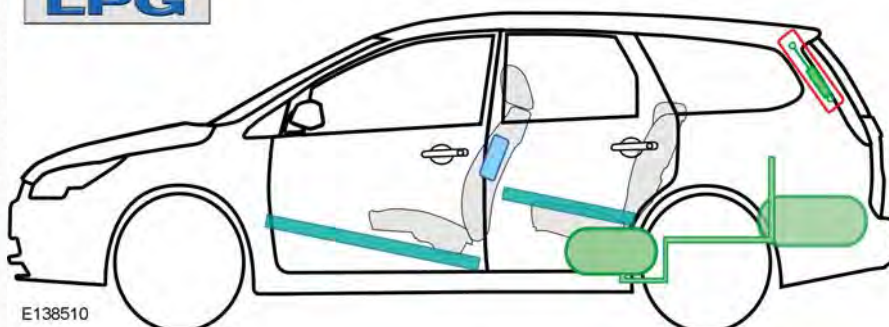

E138510

Epígrafe					F		
	Airbag		Refuerzos estructurales		Unidad de control		Sistema de protección de los peatones
	Generador de gas		Protección antivuelco activa		Batería		Depósito de gas
	Tensor del cinturón de seguridad		Dispositivo llenado de gas		Depósito de combustible		Válvula de seguridad

(Fecha De Publicacion: : 03/2011)



# FORD SERVICE

Tarjetas de rescate

## FORD Focus - LPG

5 puertas

07/2004 – 08/2007

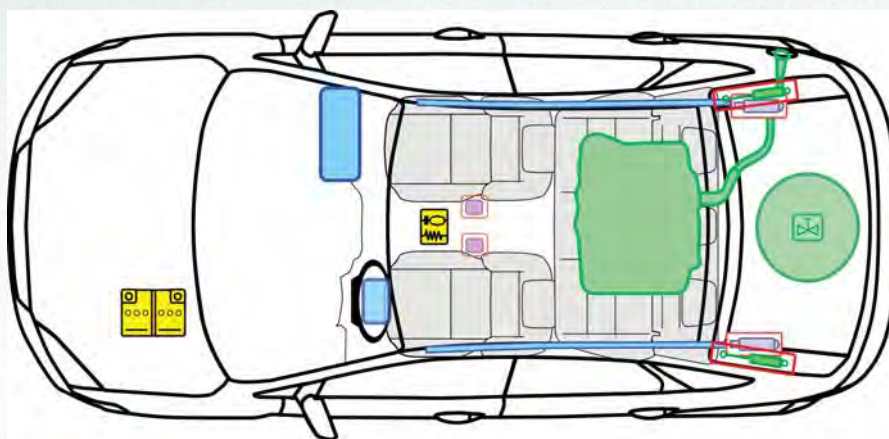

**LPG**

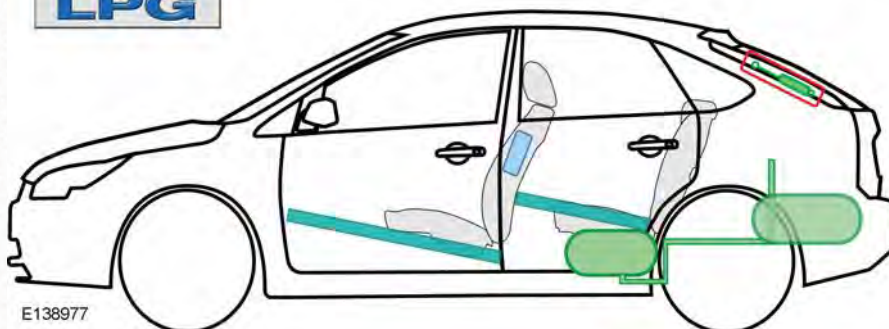

E138977

### Epígrafe

**F**

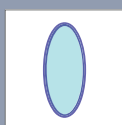

Airbag

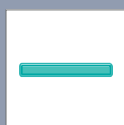

Refuerzos estructurales



Unidad de control



Sistema de protección de los peatones

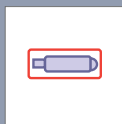

Generador de gas



Protección antivuelco activa

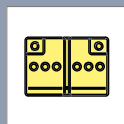

Batería



Depósito de gas

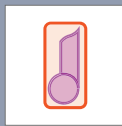

Tensor del cinturón de seguridad

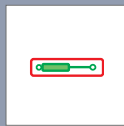

Dispositivo llenado de gas



Depósito de combustible

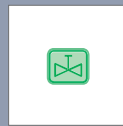

Válvula de seguridad

(Fecha De Publicacion: : 03/2011)



# FORD SERVICE

Tarjetas de rescate

## FORD Focus - LPG

5 puertas



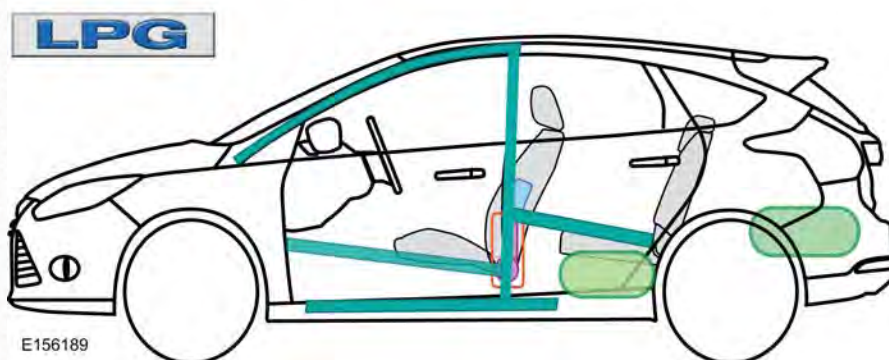
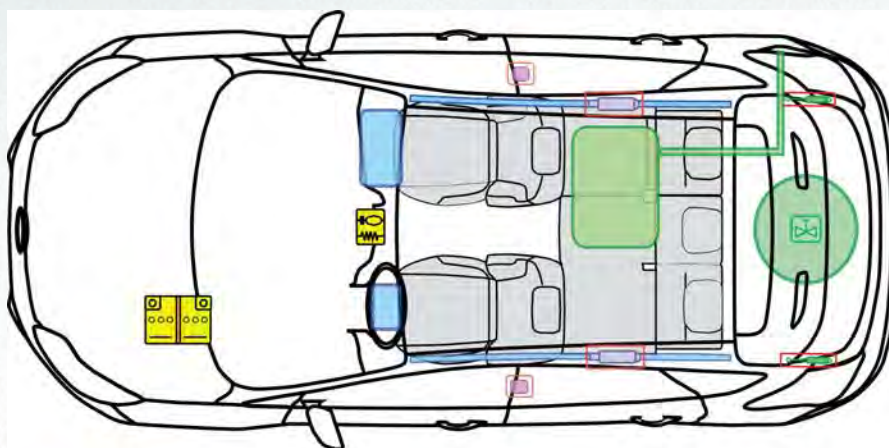





05/2012 – 09/2014

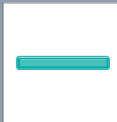

E156189

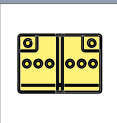
### Epígrafe

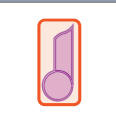
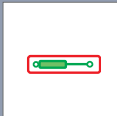
F

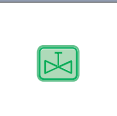
	Airbag		Refuerzos estructurales		Unidad de control		Sistema de protección de los peatones
	Generador de gas		Protección antivuelco activa		Batería		Depósito de gas
	Tensor del cinturón de seguridad		Dispositivo llenado de gas		Depósito de combustible		Válvula de seguridad

(Fecha De Publicacion: : 10/2012)



# FORD SERVICE

Tarjetas de rescate

## FORD Focus - LPG

5 puertas

09/2014 – 04/2018

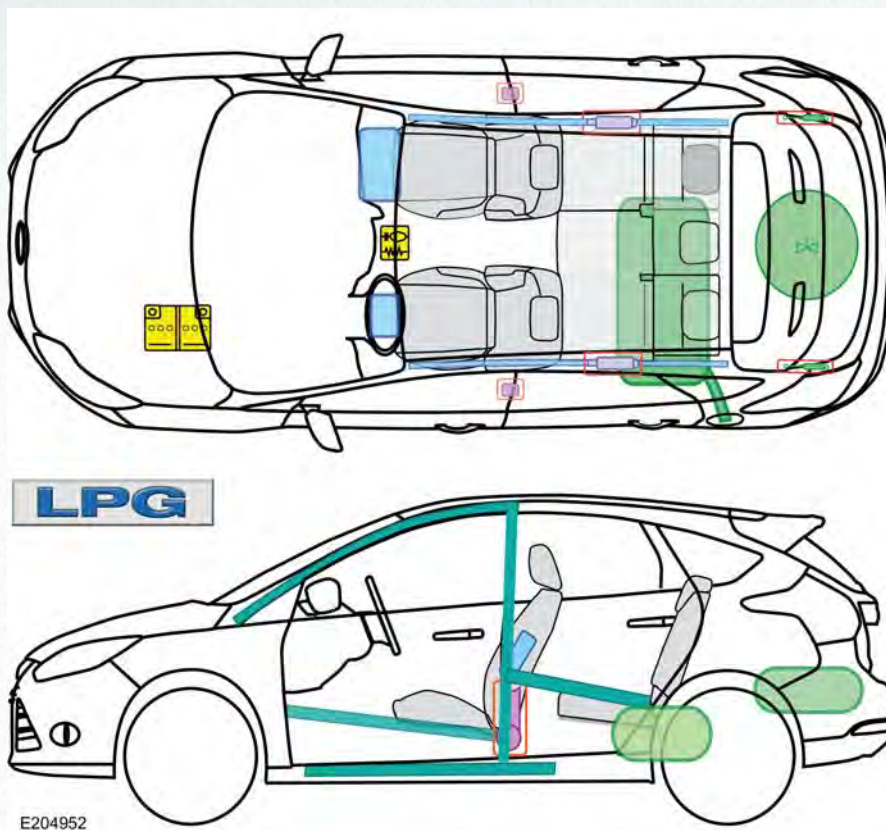

### Epígrafe

F

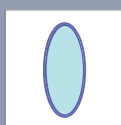

Airbag

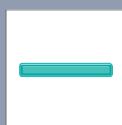

Refuerzos estructurales



Unidad de control



Sistema de protección de los peatones



Generador de gas



Protección antivuelco activa

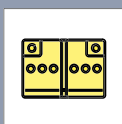

Batería



Depósito de gas

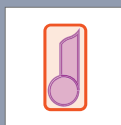

Tensor del cinturón de seguridad

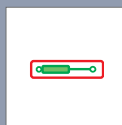

Dispositivo llenado de gas

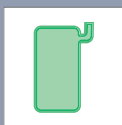

Depósito de combustible

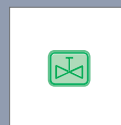

Válvula de seguridad

(Fecha De Publicacion: : 12/2014)



# FORD SERVICE

Tarjetas de rescate

## FORD Focus - CNG

5 puertas

08/2007 – 03/2011

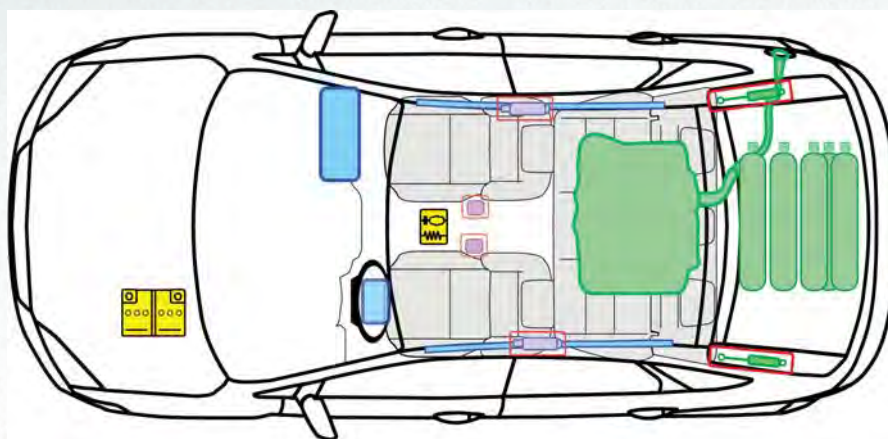

**CNG**

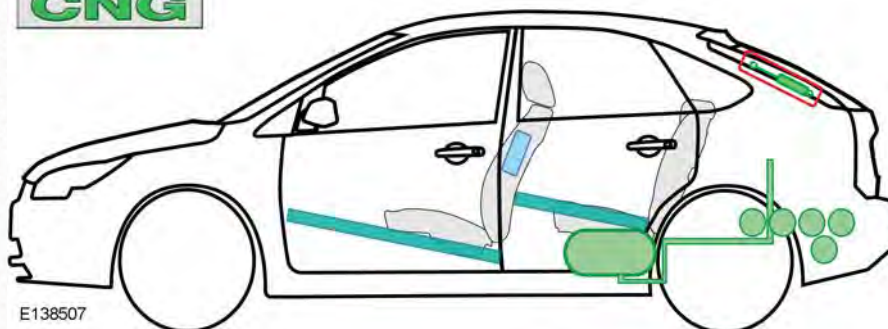

E138507

### Epígrafe

**F**

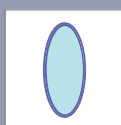

Airbag

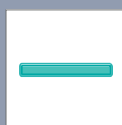

Refuerzos estructurales



Unidad de control



Sistema de protección de los peatones



Generador de gas



Protección antivuelco activa

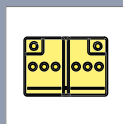

Batería



Depósito de gas

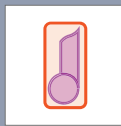

Tensor del cinturón de seguridad

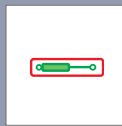

Dispositivo llenado de gas

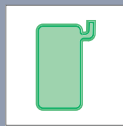

Depósito de combustible

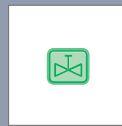

Válvula de seguridad

(Fecha De Publicacion: : 03/2011)



# FORD SERVICE

Tarjetas de rescate

## FORD Focus - CNG

5 puertas

07/2004 – 08/2007

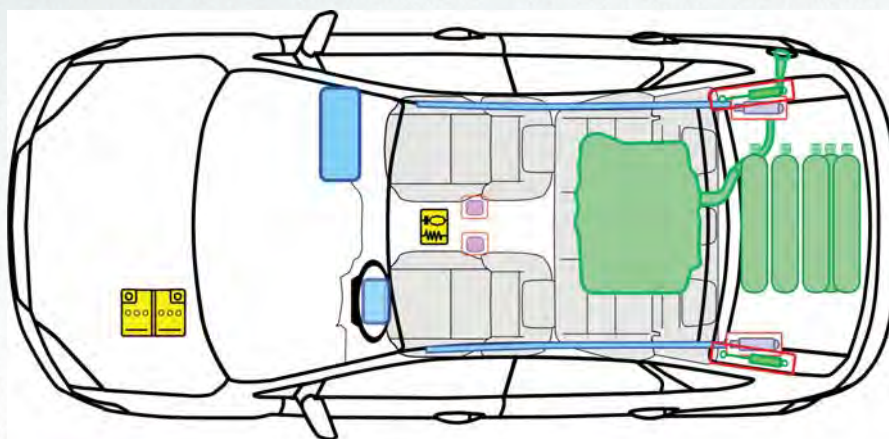



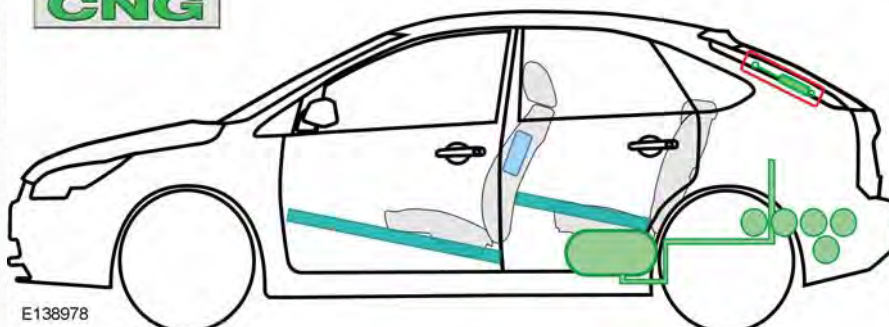







**CNG**

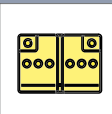

E138978

### Epígrafe

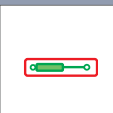
**F**

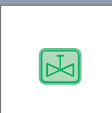
	Airbag		Refuerzos estructurales		Unidad de control		Sistema de protección de los peatones
	Generador de gas		Protección antivuelco activa		Batería		Depósito de gas
	Tensor del cinturón de seguridad		Dispositivo llenado de gas		Depósito de combustible		Válvula de seguridad

(Fecha De Publicacion: : 03/2011)



# FORD SERVICE

Tarjetas de rescate

## FORD Focus

Descapotable

03/2007 – 07/2010

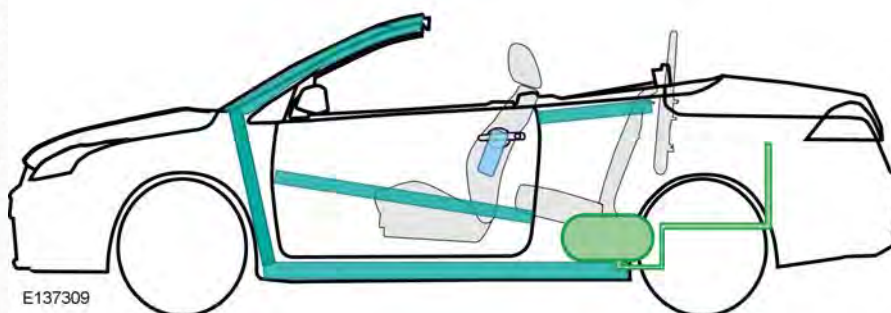
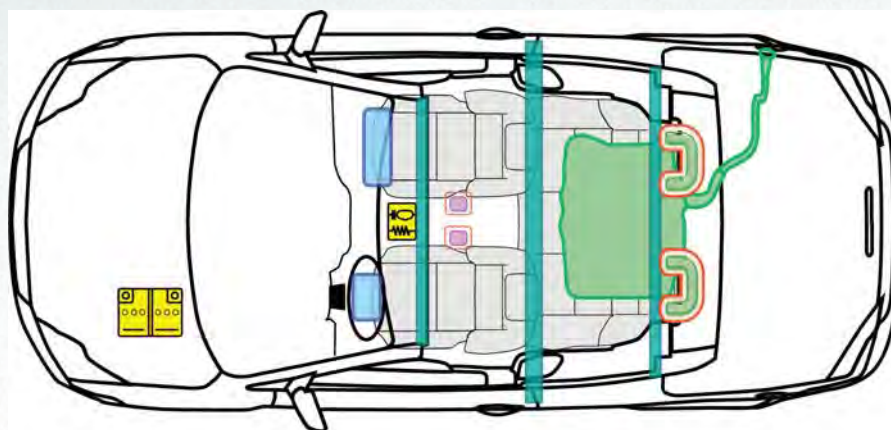

E137309

### Epígrafe

F

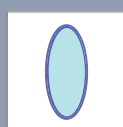

Airbag

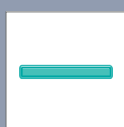

Refuerzos estructurales



Unidad de control



Sistema de protección de los peatones



Generador de gas



Protección antivuelco activa

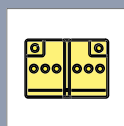

Batería

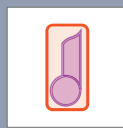

Tensor del cinturón de seguridad

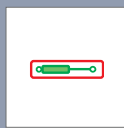

Dispositivo llenado de gas

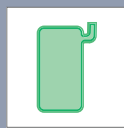

Depósito de combustible

(Fecha De Publicacion: : 03/2011)



# FORD SERVICE

Tarjetas de rescate

## FORD Focus





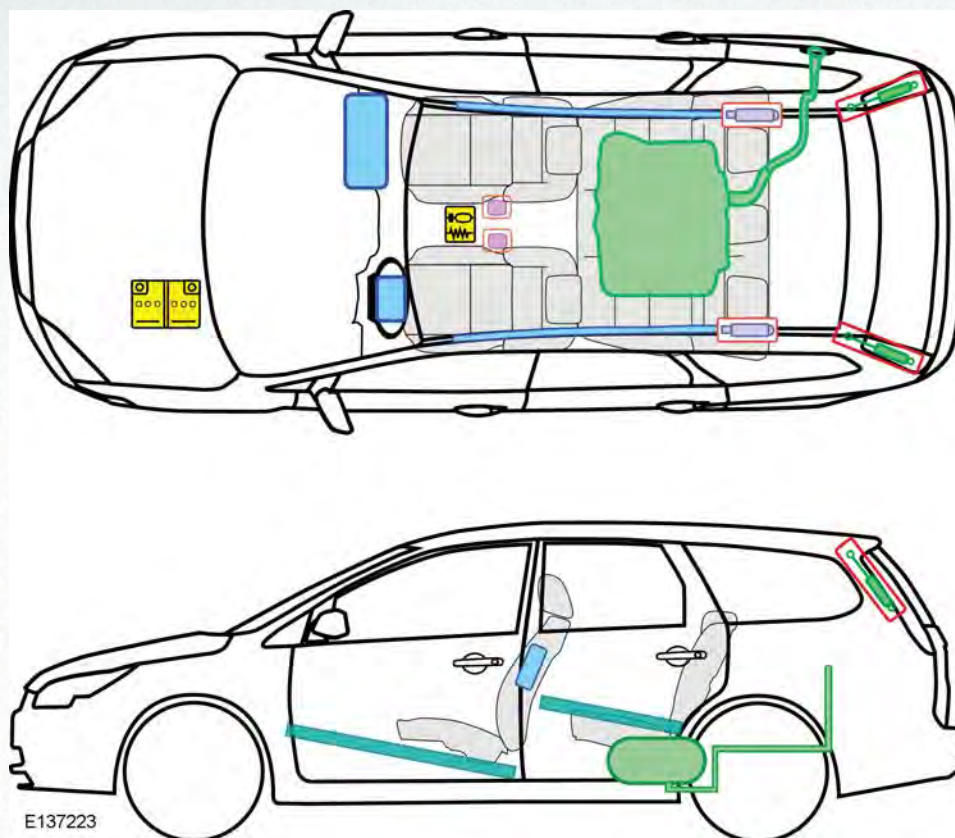

Familiar

07/2004 – 08/2007

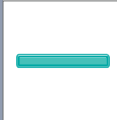

### Epígrafe

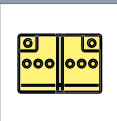
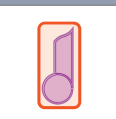
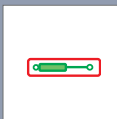
F

	Airbag		Refuerzos estructurales		Unidad de control		Sistema de protección de los peatones
	Generador de gas		Protección antivuelco activa		Batería		
	Tensor del cinturón de seguridad		Dispositivo llenado de gas		Depósito de combustible		

(Fecha De Publicacion: : 03/2011)





# FORD SERVICE

Tarjetas de rescate

## FORD Focus

Familiar



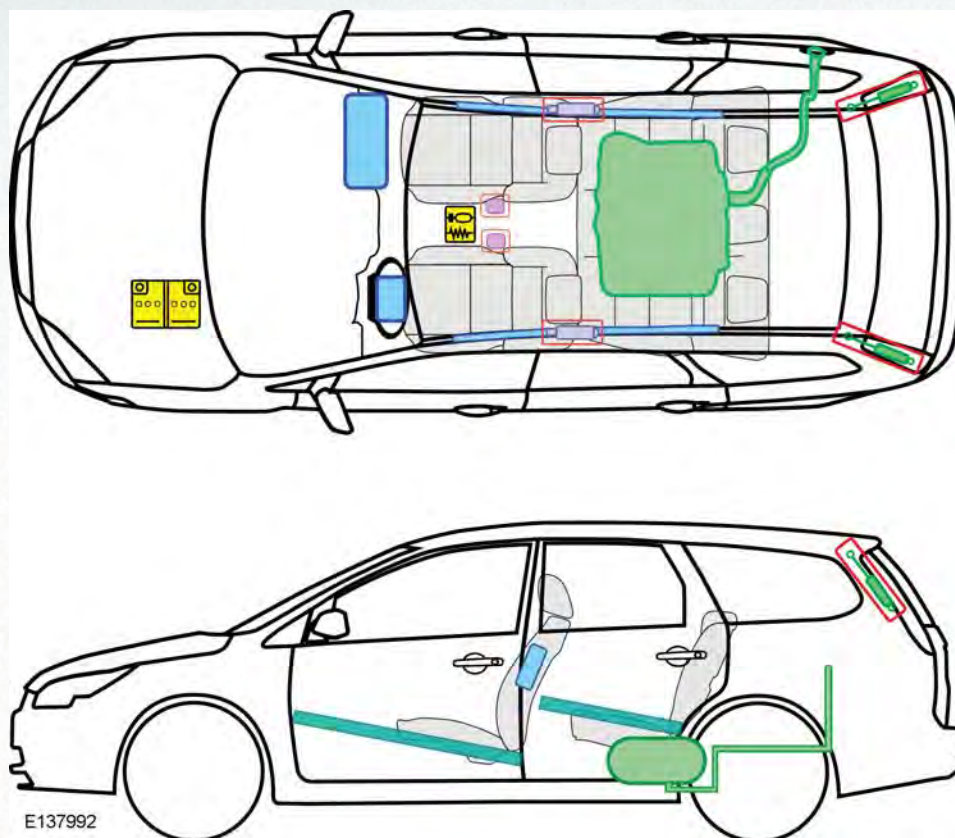





08/2007 – 03/2011



E137992

### Epígrafe

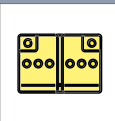
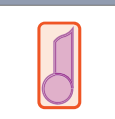
F

	Airbag		Refuerzos estructurales		Unidad de control		Sistema de protección de los peatones
	Generador de gas		Protección antivuelco activa		Batería		
	Tensor del cinturón de seguridad		Dispositivo llenado de gas		Depósito de combustible		

(Fecha De Publicacion: : 02/2011)



# FORD SERVICE

Tarjetas de rescate

## FORD Focus





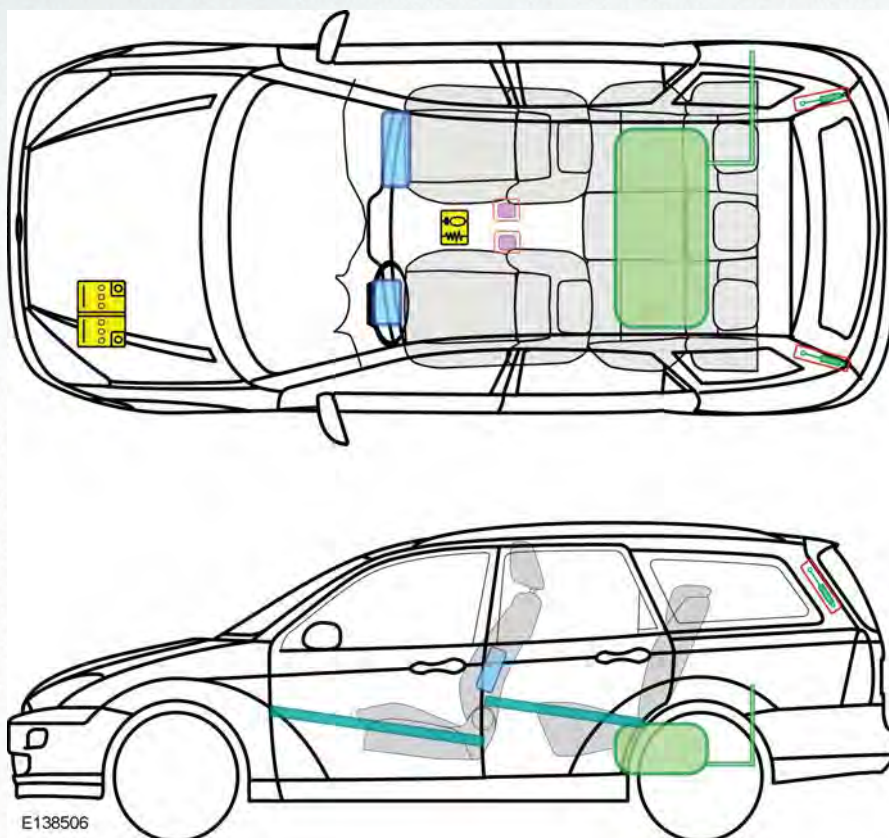





Familiar

08/1998 – 12/2004

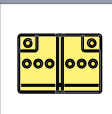

### Epígrafe

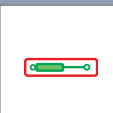
F

	Airbag		Refuerzos estructurales		Unidad de control		Sistema de protección de los peatones
	Generador de gas		Protección antivuelco activa		Batería		
	Tensor del cinturón de seguridad		Dispositivo llenado de gas		Depósito de combustible		

(Fecha De Publicacion: : 03/2011)



# FORD SERVICE

Tarjetas de rescate

## FORD Focus

Familiar

03/2011 – 09/2014

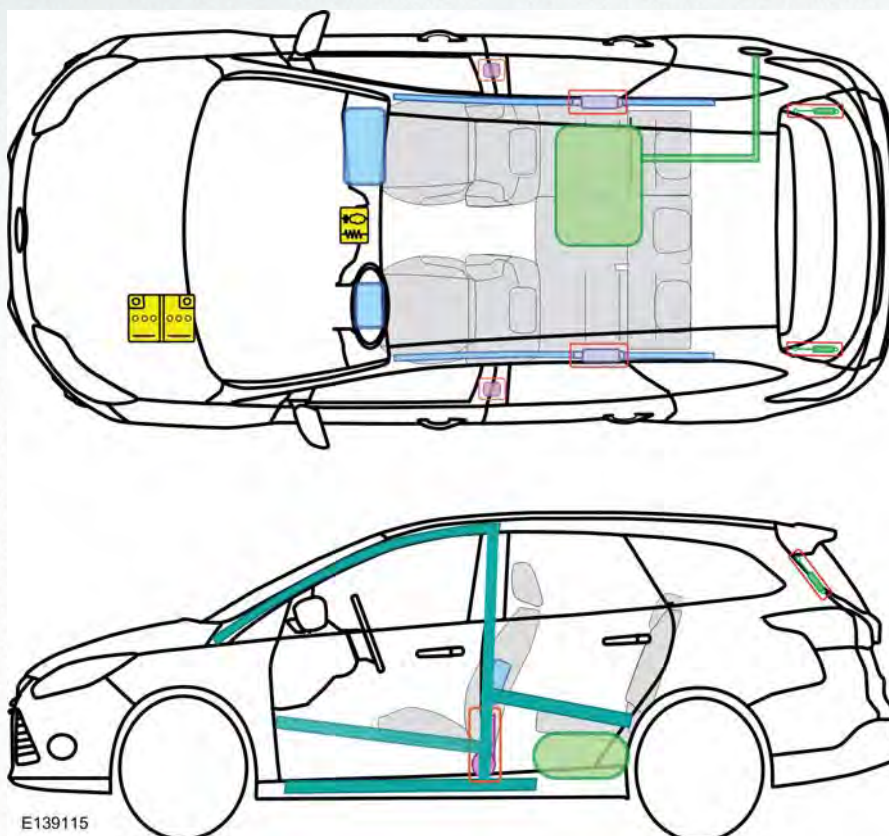

E139115

### Epígrafe

F

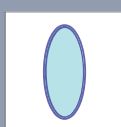

Airbag

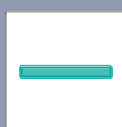

Refuerzos estructurales



Unidad de control



Sistema de protección de los peatones



Generador de gas



Protección antivuelco activa

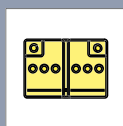

Batería

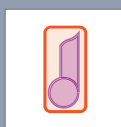

Tensor del cinturón de seguridad

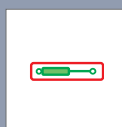

Dispositivo llenado de gas



Depósito de combustible

(Fecha De Publicacion: : 10/2012)



# FORD SERVICE

Tarjetas de rescate

## FORD Focus

Familiar

09/2014 – 04/2018

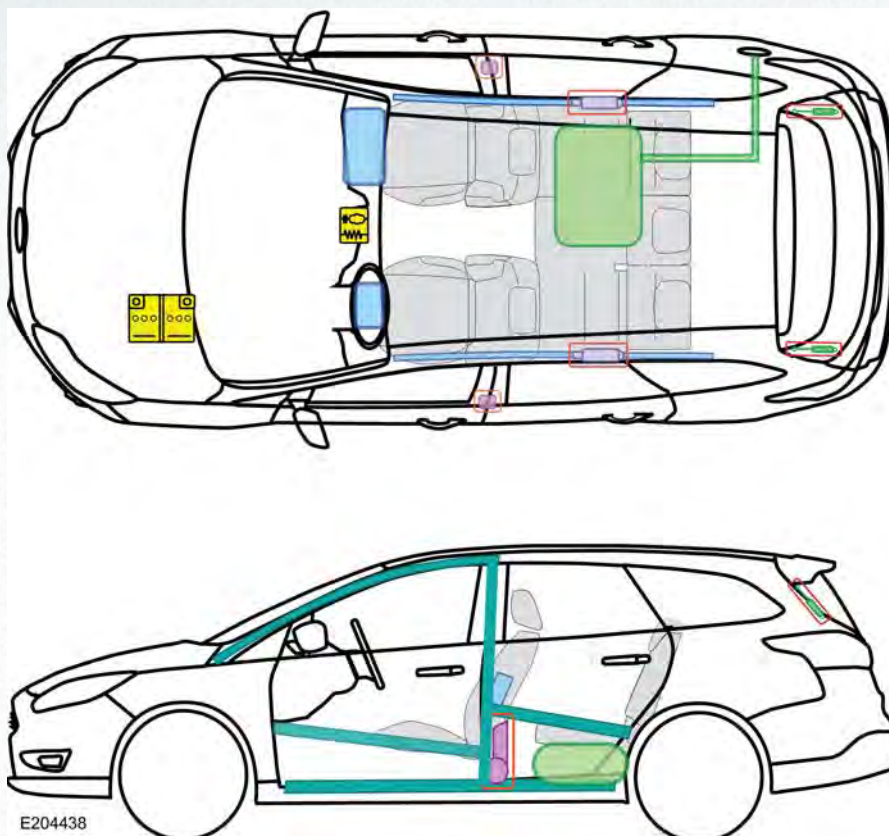

E204438

### Epígrafe

F

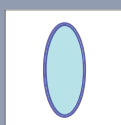

Airbag

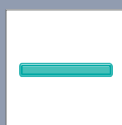

Refuerzos estructurales



Unidad de control



Sistema de protección de los peatones

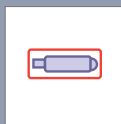

Generador de gas



Protección antivuelco activa

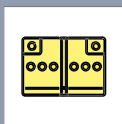

Batería

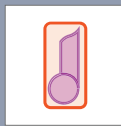

Tensor del cinturón de seguridad

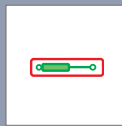

Dispositivo llenado de gas

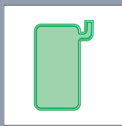

Depósito de combustible

(Fecha De Publicacion: : 12/2014)



# FORD SERVICE

Tarjetas de rescate

## FORD Focus

Familiar

04/2018 – >

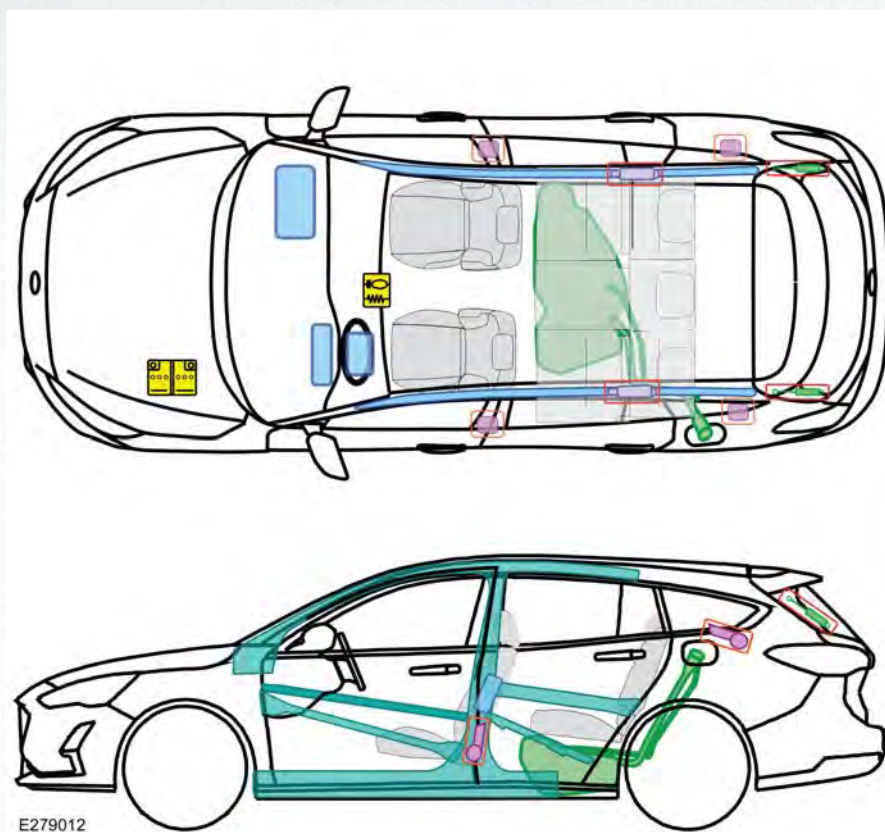

E279012

### Epígrafe

F

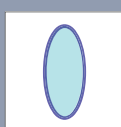

Airbag

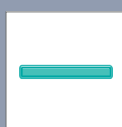

Refuerzos estructurales



Unidad de control



Sistema de protección de los peatones



Generador de gas



Protección antivuelco activa

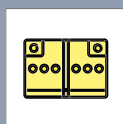

Batería

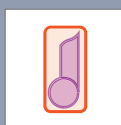

Tensor del cinturón de seguridad

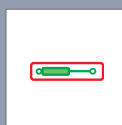

Dispositivo llenado de gas



Depósito de combustible

(Fecha De Publicacion: : 01/2019)



# FORD SERVICE

Tarjetas de rescate

## FORD Focus - LPG

Familiar

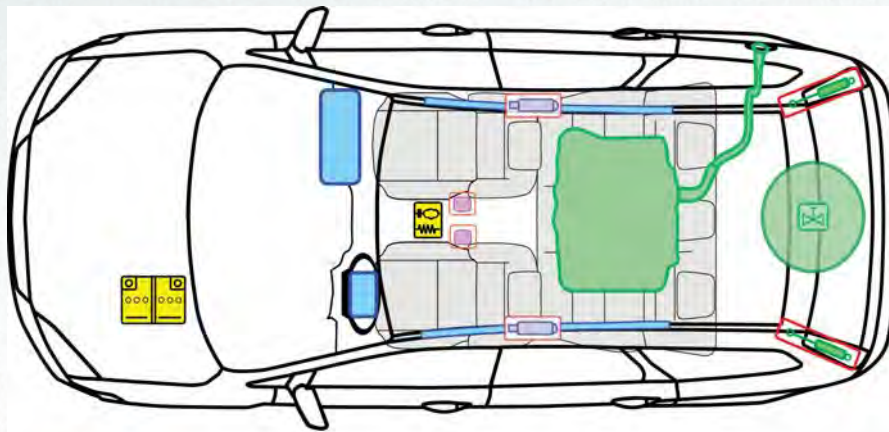

08/2007 – 03/2011

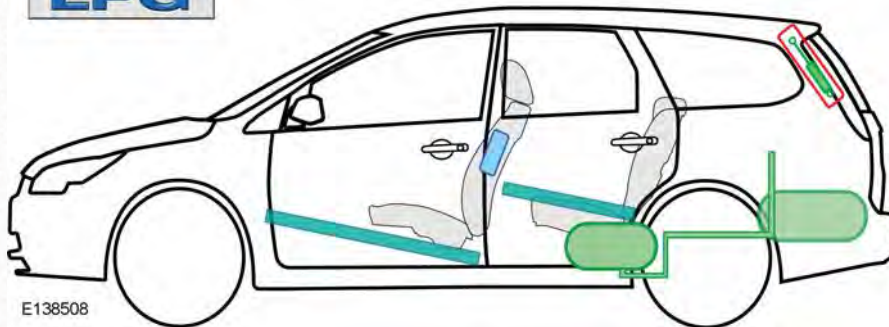

**LPG**

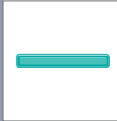

E138508

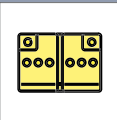
Epígrafe					F		
	Airbag		Refuerzos estructurales		Unidad de control		Sistema de protección de los peatones
	Generador de gas		Protección antivuelco activa		Batería		Depósito de gas
	Tensor del cinturón de seguridad		Dispositivo llenado de gas		Depósito de combustible		Válvula de seguridad

(Fecha De Publicacion: : 03/2011)



# FORD SERVICE

Tarjetas de rescate

## FORD Focus - LPG

Familiar

07/2004 – 08/2007

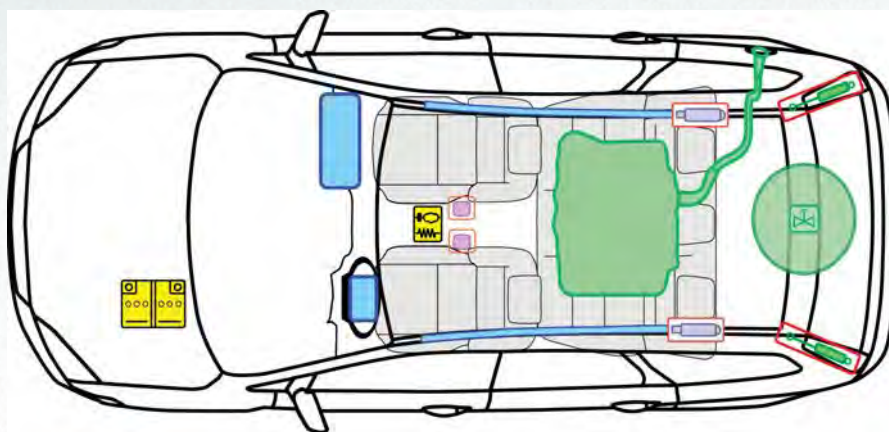

**LPG**

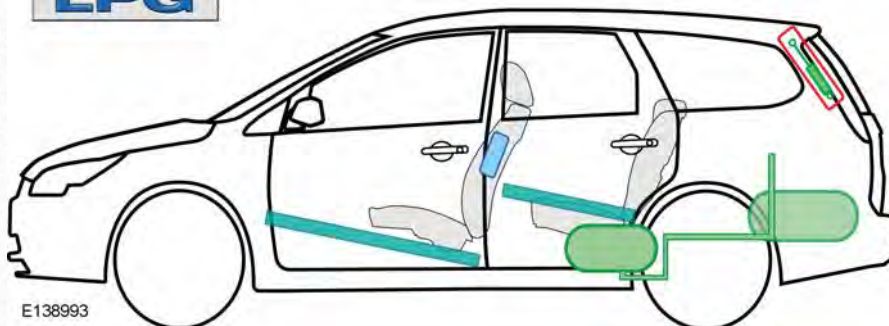

E138993

### Epígrafe

**F**

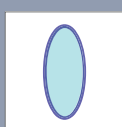

Airbag

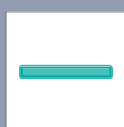

Refuerzos estructurales



Unidad de control



Sistema de protección de los peatones



Generador de gas



Protección antivuelco activa

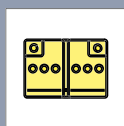

Batería



Depósito de gas

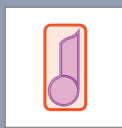

Tensor del cinturón de seguridad

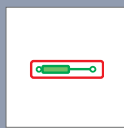

Dispositivo llenado de gas



Depósito de combustible

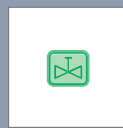

Válvula de seguridad

(Fecha De Publicacion: : 03/2011)



# FORD SERVICE

Tarjetas de rescate

## FORD Focus - LPG

Familiar

05/2012 – 09/2014

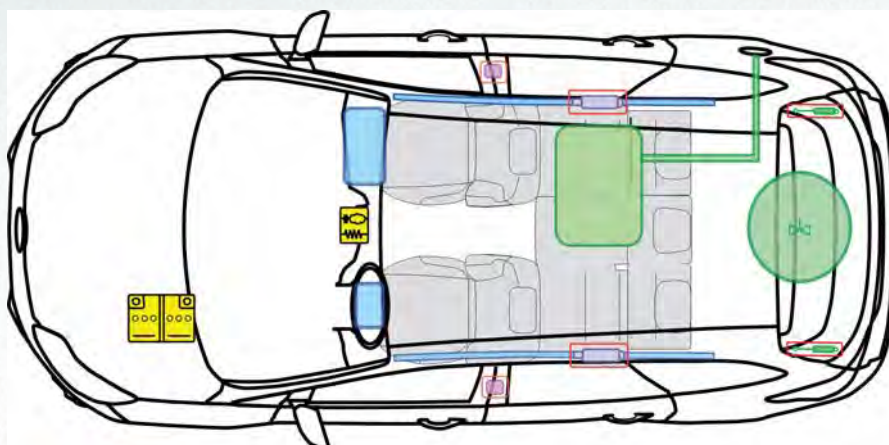

**LPG**

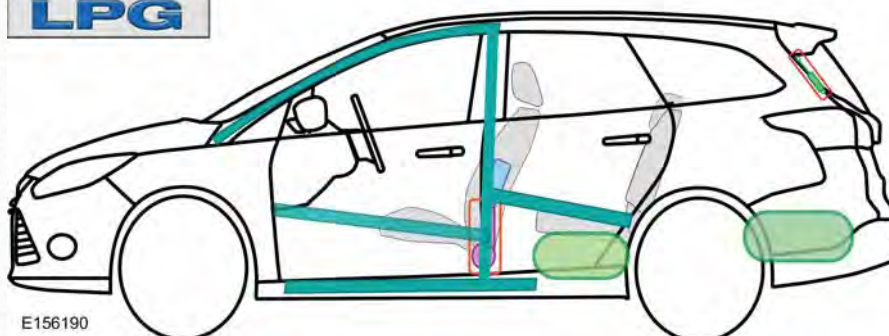

E156190

### Epígrafe

**F**

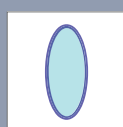

Airbag

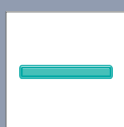

Refuerzos estructurales



Unidad de control



Sistema de protección de los peatones



Generador de gas



Protección antivuelco activa

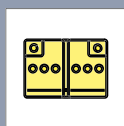

Batería



Depósito de gas

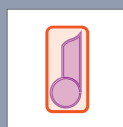

Tensor del cinturón de seguridad

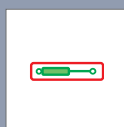

Dispositivo llenado de gas



Depósito de combustible



Válvula de seguridad

(Fecha De Publicacion: : 07/2013)





# FORD SERVICE

Tarjetas de rescate

## FORD Focus - LPG

Familiar

09/2014 – 04/2018

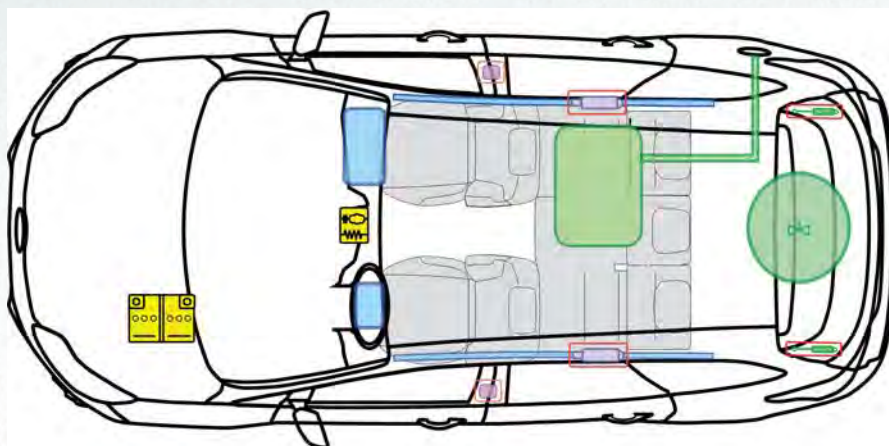

**LPG**

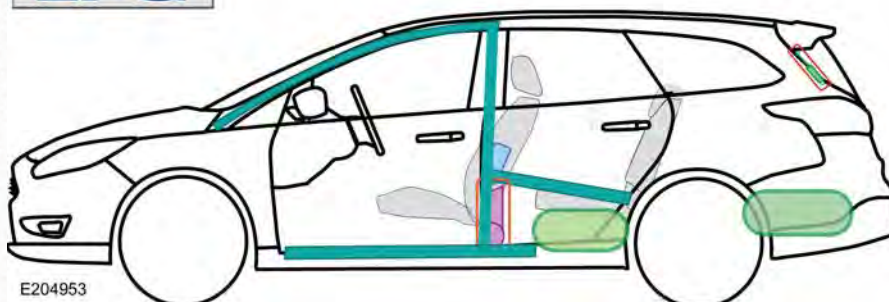

E204953

### Epígrafe

**F**

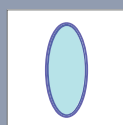

Airbag

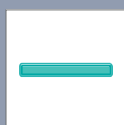

Refuerzos estructurales



Unidad de control



Sistema de protección de los peatones



Generador de gas



Protección antivuelco activa

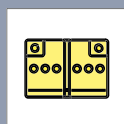

Batería



Depósito de gas

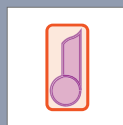

Tensor del cinturón de seguridad

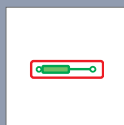

Dispositivo llenado de gas

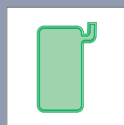

Depósito de combustible

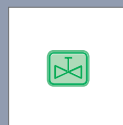

Válvula de seguridad

(Fecha De Publicacion: : 12/2014)



## FORD Focus E=LECTRIC



E171187

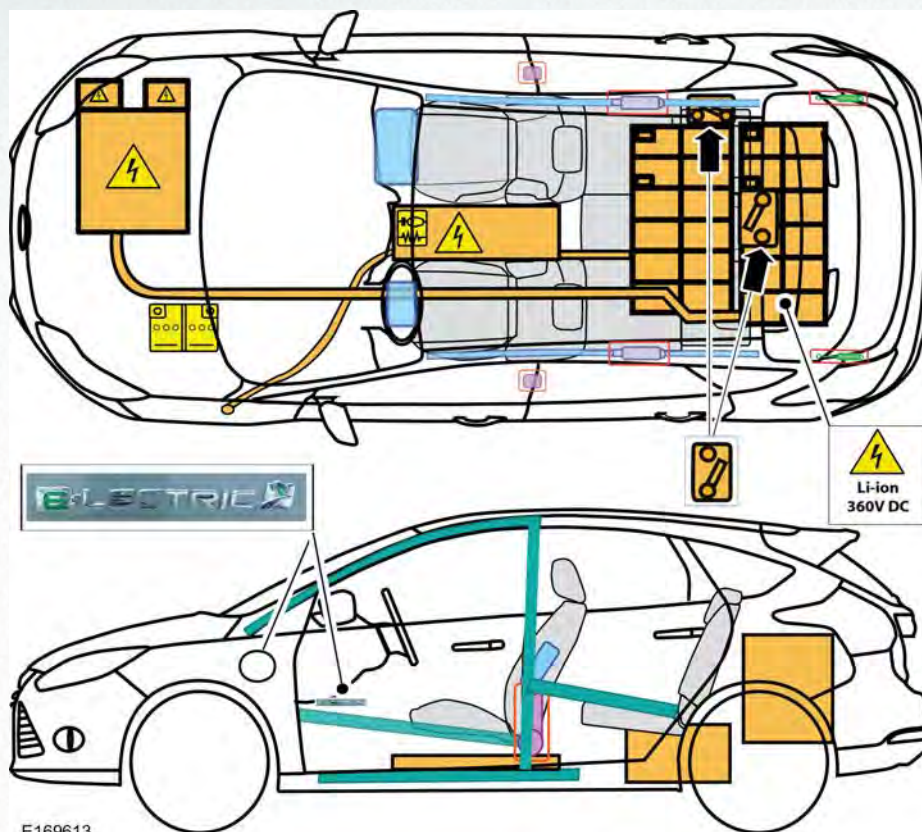

E169613

### Epígrafe

F

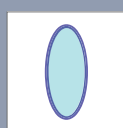

Airbag

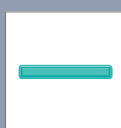

Refuerzos estructurales



Unidad de control



Batería de Alto Voltaje



Sistema de protección de los peatones



Generador de gas



Protección antivuelco activa



Componente de Alto Voltaje

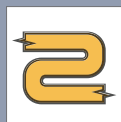

Cable de Alto Voltaje

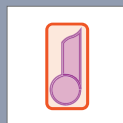

Tensor del cinturón de seguridad

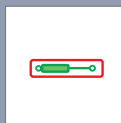

Dispositivo llenado de gas



Sensor mecánico



Punto de desconexión del Alto Voltaje

(Fecha De Publicacion: : 05/2014)

## Desactivación del sistema de alta tensión

### Introducción

**¡TENGA EN CUENTA SIEMPRE QUE EL SISTEMA DE ALTA TENSIÓN DEL VEHÍCULO ESTÁ ENCENDIDO!  
ANTES DE ACCEDER AL VEHÍCULO, ASEGÚRESE DE QUE TODAS LAS ALIMENTACIONES ELÉCTRICAS  
EXTERNAS ESTÁN DESCONECTADAS (EJ.: CARGADOR ELÉCTRICO, HERRAMIENTAS ELÉCTRICAS).  
Si no se respetan estas advertencias, se pueden producir lesiones graves o incluso provocar la muerte.**

### IDENTIFICACIÓN DEL VEHÍCULO ELÉCTRICO

#### Identificación por las características del vehículo



E171275

1. Etiqueta E=LECTRIC a ambos lados del vehículo, en las puertas delanteras y en el portón trasero
2. Puerto de carga de alta tensión (integrado en la aleta delantera izquierda)
3. Sin sistema de escape
4. Sin tapas del depósito de combustible (generalmente localizadas en el lado derecho)

## Identificación por las características del compartimento motor



1. Cubierta del motor superior E=LECTRIC
2. Mazo de cables naranja de alta tensión

## FUNCIONES DE DESCONEXIÓN ELÉCTRICA DE ALTA TENSIÓN

**▲ PELIGRO:** Los daños en los vehículos eléctricos provocados por una colisión pueden poner en peligro los sistemas de seguridad de alta tensión y suponer un posible riesgo de descarga eléctrica de alta tensión. Extreme las precauciones y lleve siempre el equipamiento de seguridad del equipo de protección personal adecuado. Quítese todos los accesorios metálicos, incluidos reloj y anillos. Si no se respetan estas advertencias, se pueden producir lesiones graves o incluso provocar la muerte.

**Contacto en posición de desconexión:** Siempre que el contacto esté en posición de desconexión (y el vehículo no se esté cargando), el sistema de alta tensión quedará aislado.

**Desconexión del servicio de alta tensión:** Si desmonta cualquiera de las desconexiones de servicio de alta tensión, el sistema de alta tensión quedará aislado.

### Desactivación

#### Método 1

Si no es posible acceder a la batería, pase al método 2.

# FORD SERVICE

Tarjetas de rescate

## 1. Compruebe si el sistema de alta tensión está recibiendo alimentación.



## 2. Si el sistema de alta tensión está activo, pulse una vez el botón de arranque.



### 3. Desconecte el cable de la batería de 12 V.

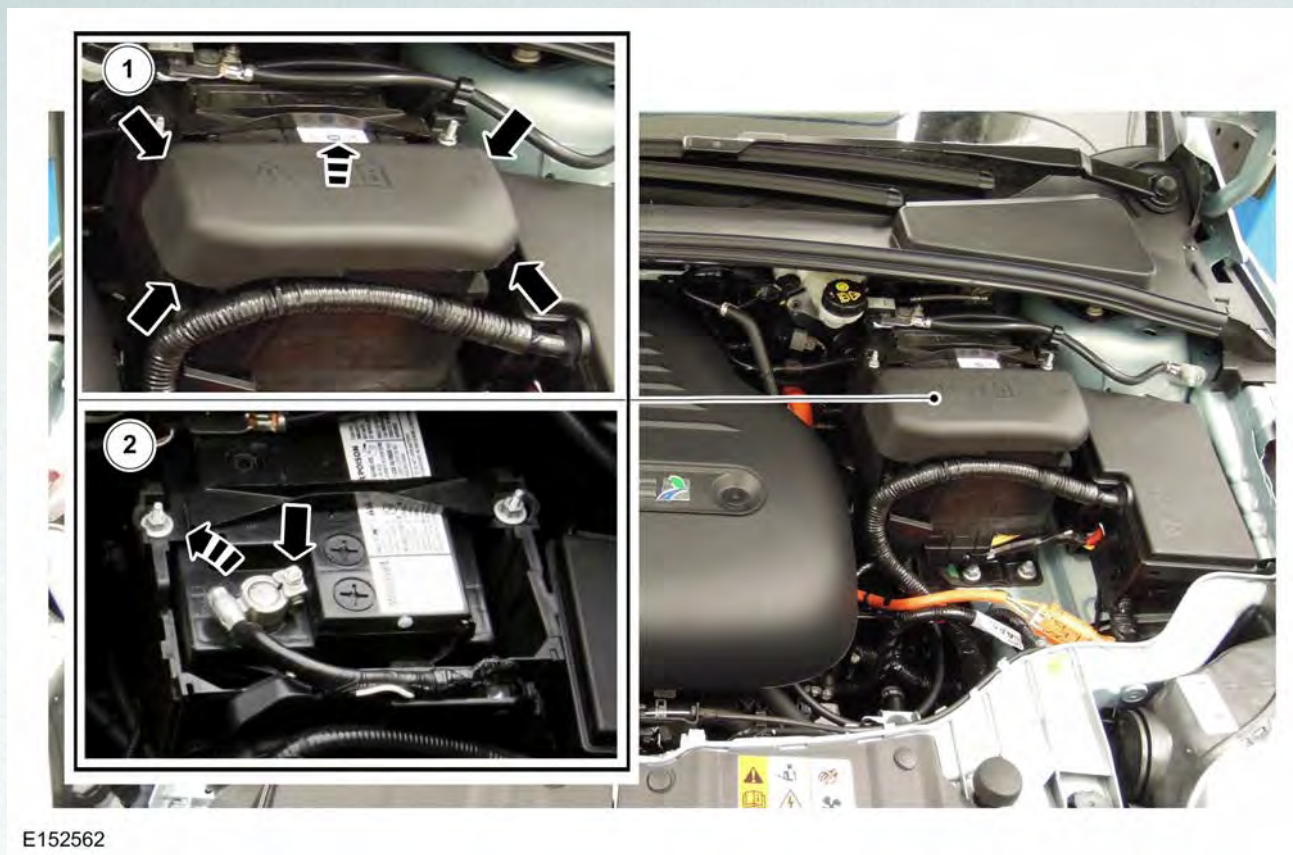

E152562

### Método 2

**NOTA:** Para acceder a la desconexión del servicio de alta tensión superior de la batería, debe bajar el respaldo del asiento trasero hasta el 60% de su recorrido.

**Si no es posible bajar el respaldo del asiento trasero, pase al método 3.**

1. Localice la palanca de desbloqueo del respaldo del asiento, en la parte superior del respaldo.

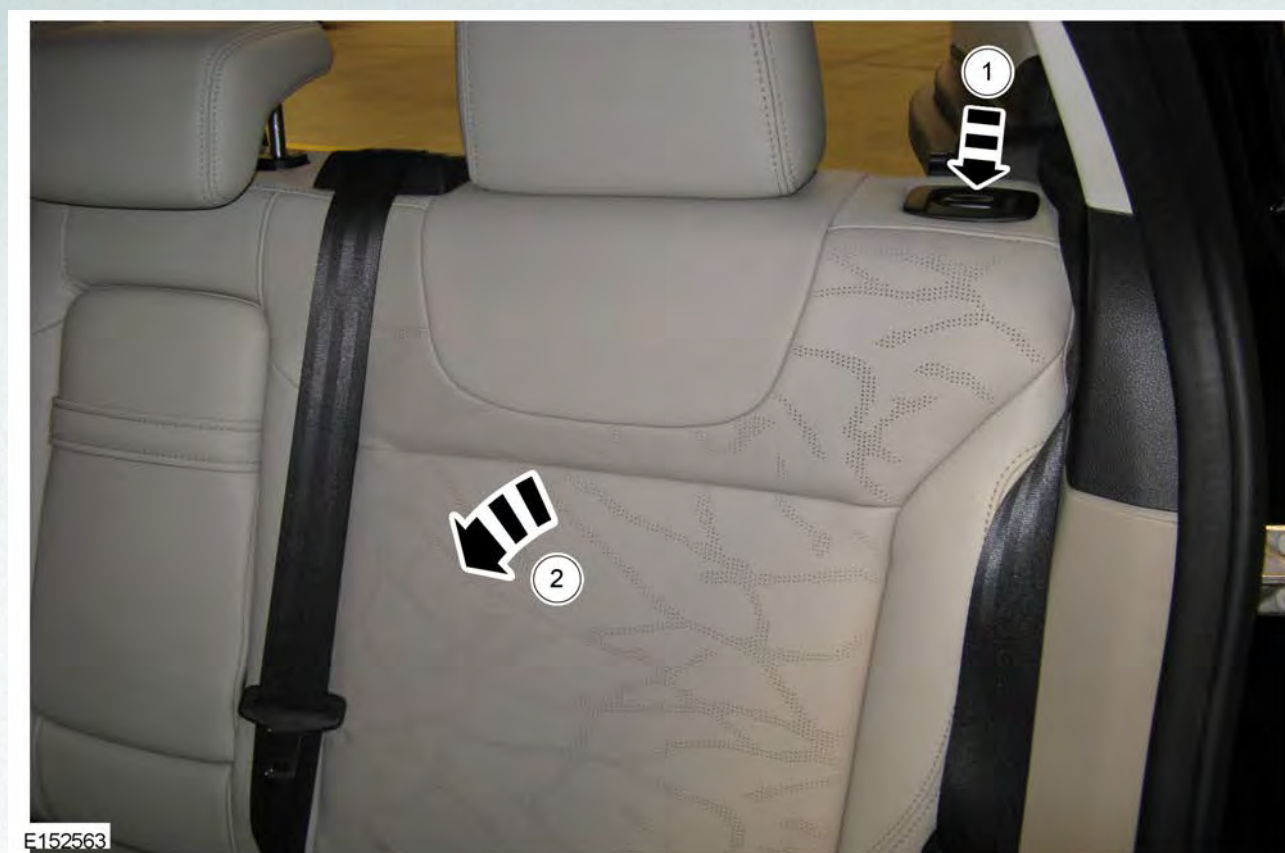

## 2. Retire la cubierta para acceder a la desconexión superior del servicio de la batería.



E152564



# FORD SERVICE

Tarjetas de rescate

3. Apriete la pestaña de desbloqueo en la parte superior de la desconexión del servicio y gire la manecilla de desbloqueo hacia abajo unos 45 grados.



4. Apriete la pestaña de desbloqueo de nuevo y gire la manecilla otros 45 grados hasta la posición de desbloqueo completa. Tire hacia fuera de la manecilla para retirar la desconexión superior del servicio.



### Método 3

**NOTA:** La desconexión de servicio inferior se extrae de la misma manera que la superior. Para acceder a la desconexión del servicio de alta tensión inferior de la batería, levante la parte trasera del vehículo con un gato adecuado.

- 1. La desconexión del servicio de alta tensión inferior de la batería está situada en el lateral derecho del vehículo, cerca del neumático trasero.**



E152568

- 2. Retire la sujeción del soporte del cable del freno de estacionamiento y aparte a un lado tanto este cable como el soporte. Apriete la pestaña de desbloqueo en la parte trasera de la desconexión del servicio y gire la manecilla de desbloqueo unos 45 grados hacia la parte delantera del vehículo. Apriete la pestaña de desbloqueo de nuevo y gire la manecilla de desbloqueo otros 45 grados hasta**

**la posición de desbloqueo completa. Tire hacia fuera de la manecilla para retirar la desconexión inferior del servicio.**



(Fecha De Publicacion: : 05/2014)

# FORD SERVICE

Tarjetas de rescate

## FORD Focus mHEV

1,0l EcoBoost (92kW/125CV) (B7), 1,0l EcoBoost (114kW/155CV) (M0), 5 puertas

04/2018 – >

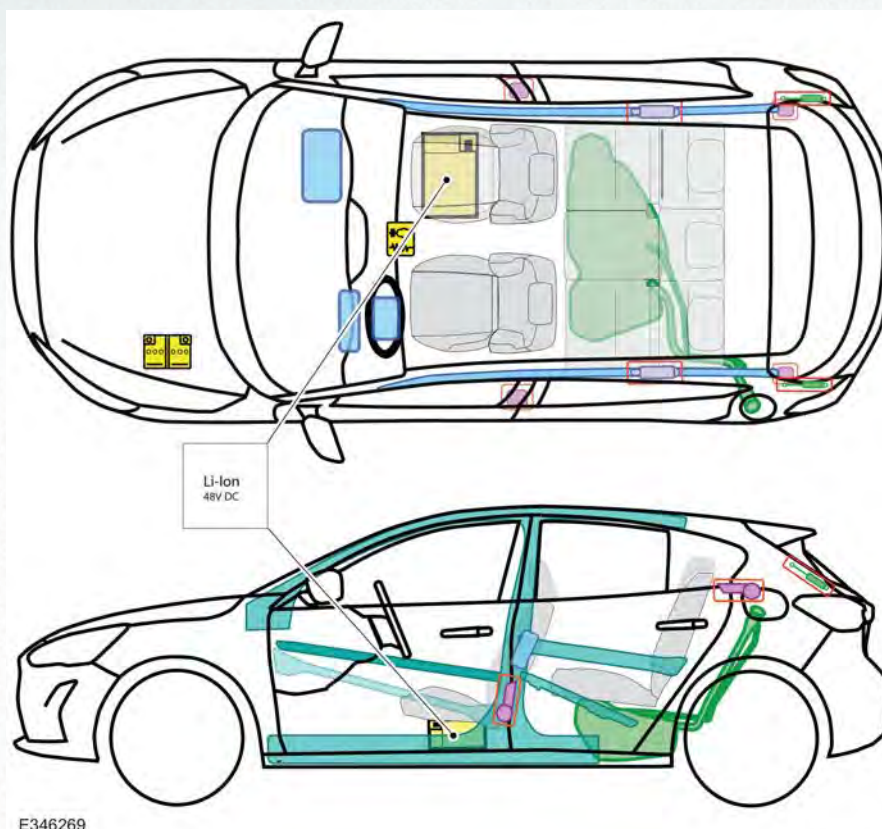

### Epígrafe

F

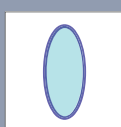

Airbag



Refuerzos estructurales



Unidad de control



Sistema de protección de los peatones



Generador de gas



Protección antivuelco activa

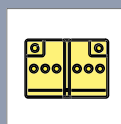

Batería

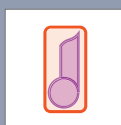

Tensor del cinturón de seguridad

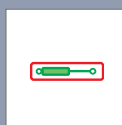

Dispositivo llenado de gas



Depósito de combustible

(Fecha De Publicacion: : 10/2020)



# FORD SERVICE

Tarjetas de rescate

## FORD Focus mHEV

1,0l EcoBoost (92kW/125CV) (B7), 1,0l EcoBoost (114kW/155CV) (M0), Familiar

04/2018 – >

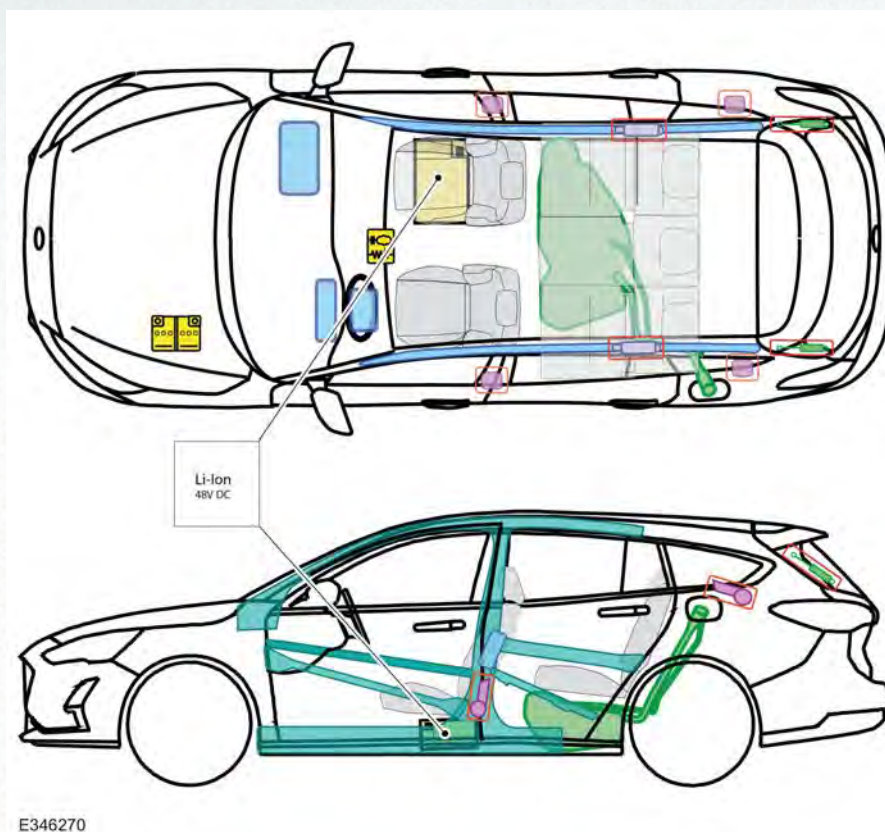

E346270

### Epígrafe

F

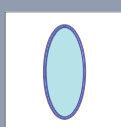

Airbag

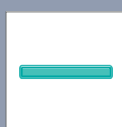

Refuerzos estructurales



Unidad de control



Sistema de protección de los peatones



Generador de gas



Protección antivuelco activa

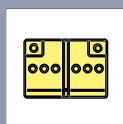

Batería

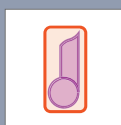

Tensor del cinturón de seguridad

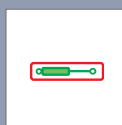

Dispositivo llenado de gas



Depósito de combustible

(Fecha De Publicacion: : 10/2020)



# FORD SERVICE

Tarjetas de rescate

## FORD Fusion

06/2002 - >

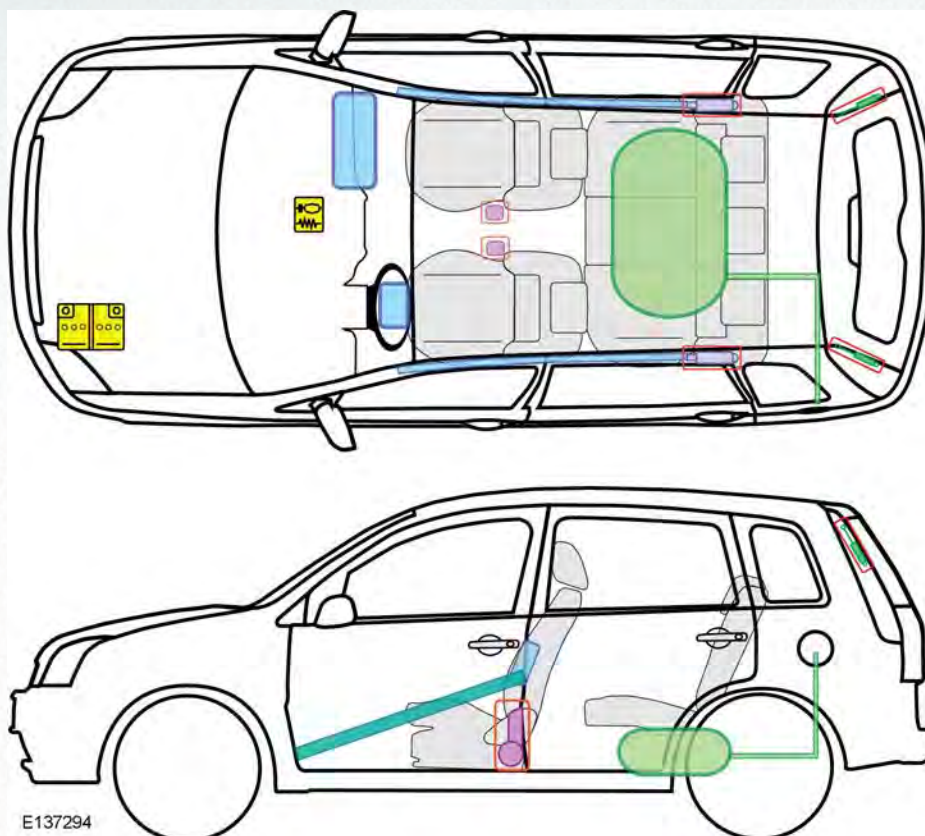

### Epígrafe

F

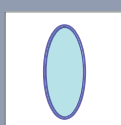

Airbag

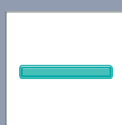

Refuerzos estructurales



Unidad de control



Sistema de protección de los peatones



Generador de gas



Protección antivuelco activa

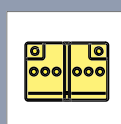

Batería

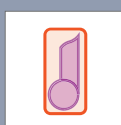

Tensor del cinturón de seguridad

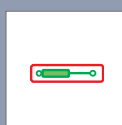

Dispositivo llenado de gas



Depósito de combustible

(Fecha De Publicacion: : 01/2011)



# FORD SERVICE

Tarjetas de rescate

## FORD Galaxy

02/2006 – 05/2015

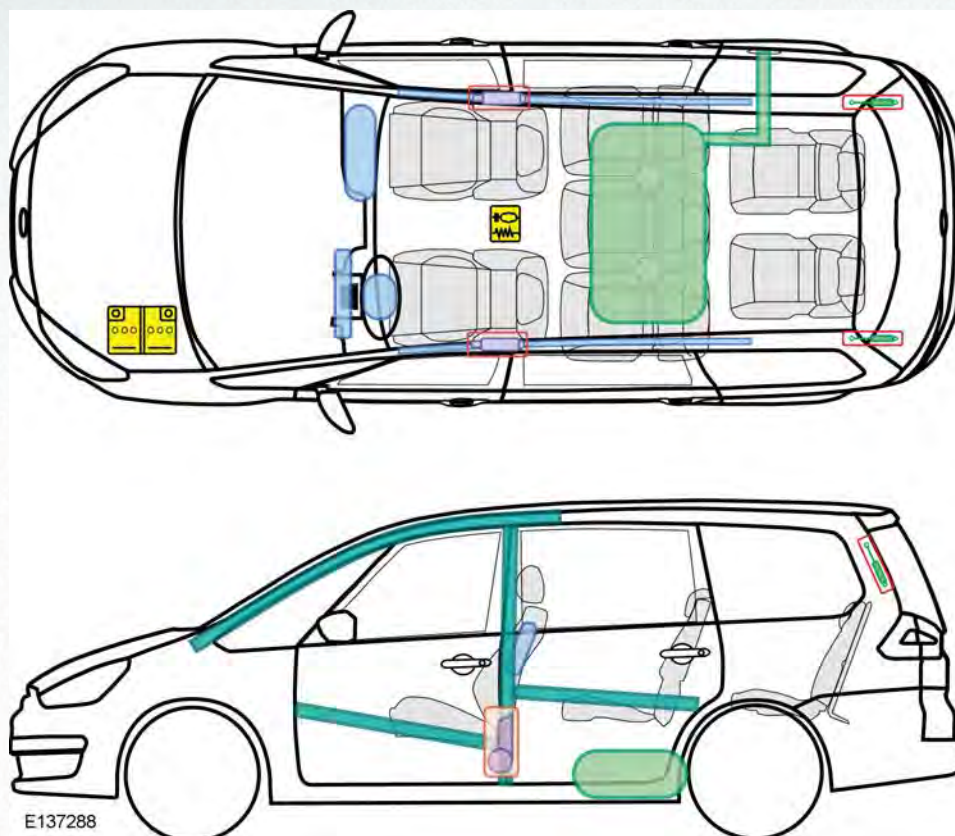

### Epígrafe

**G**

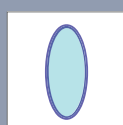

Airbag



Refuerzos estructurales



Unidad de control



Sistema de protección de los peatones



Generador de gas



Protección antivuelco activa

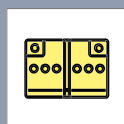

Batería

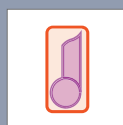

Tensor del cinturón de seguridad

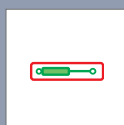

Dispositivo llenado de gas



Depósito de combustible

(Fecha De Publicacion: : 06/2015)





# FORD SERVICE

Tarjetas de rescate

## FORD Galaxy



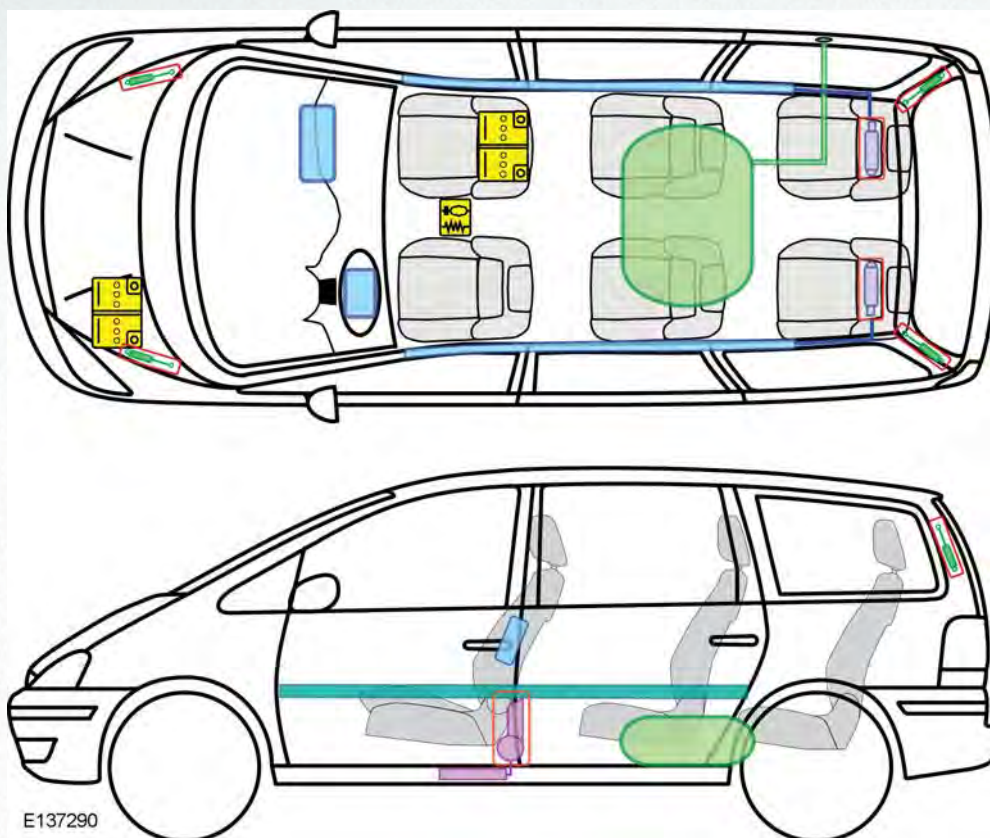





04/2000 – 02/2006



E137290

### Epígrafe

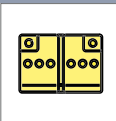
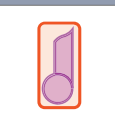
G

	Airbag		Refuerzos estructurales		Unidad de control		Sistema de protección de los peatones
	Generador de gas		Protección antivuelco activa		Batería		
	Tensor del cinturón de seguridad		Dispositivo llenado de gas		Depósito de combustible		

(Fecha De Publicacion: : 01/2011)



# FORD SERVICE

Tarjetas de rescate

## FORD Galaxy

5 puertas LMV

05/2015 – >

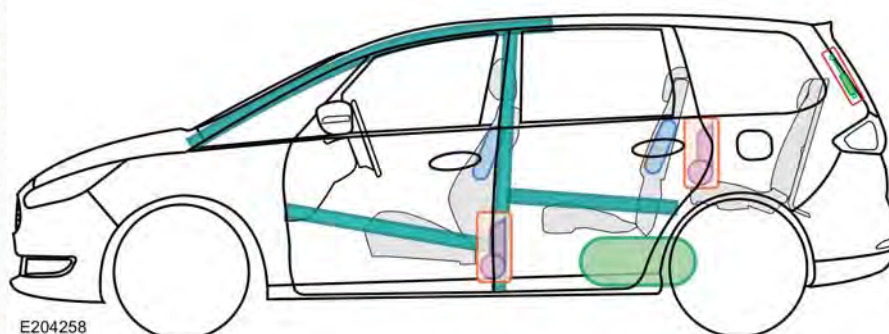
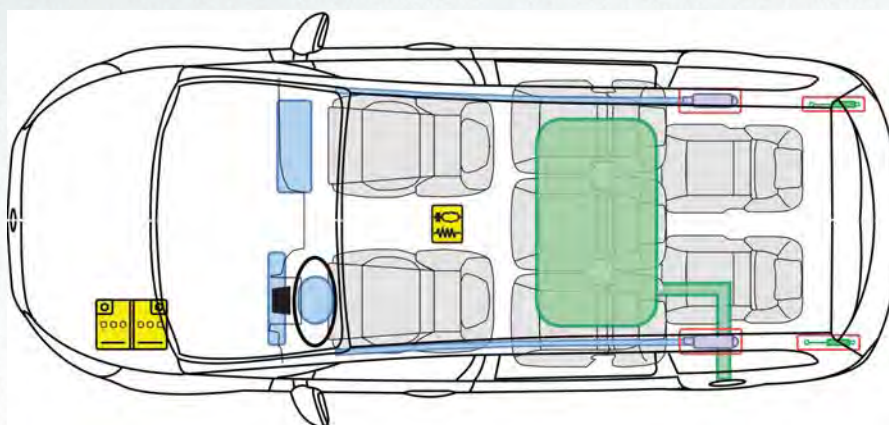

### Epígrafe

G

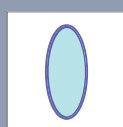

Airbag



Refuerzos estructurales



Unidad de control



Sistema de protección de los peatones



Generador de gas



Protección antivuelco activa

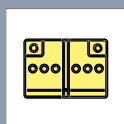

Batería

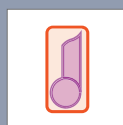

Tensor del cinturón de seguridad

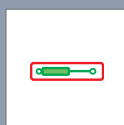

Dispositivo llenado de gas



Depósito de combustible

(Fecha De Publicacion: : 06/2015)



# FORD SERVICE

Tarjetas de rescate

FORD **GT**

12/2017 – >



E289973

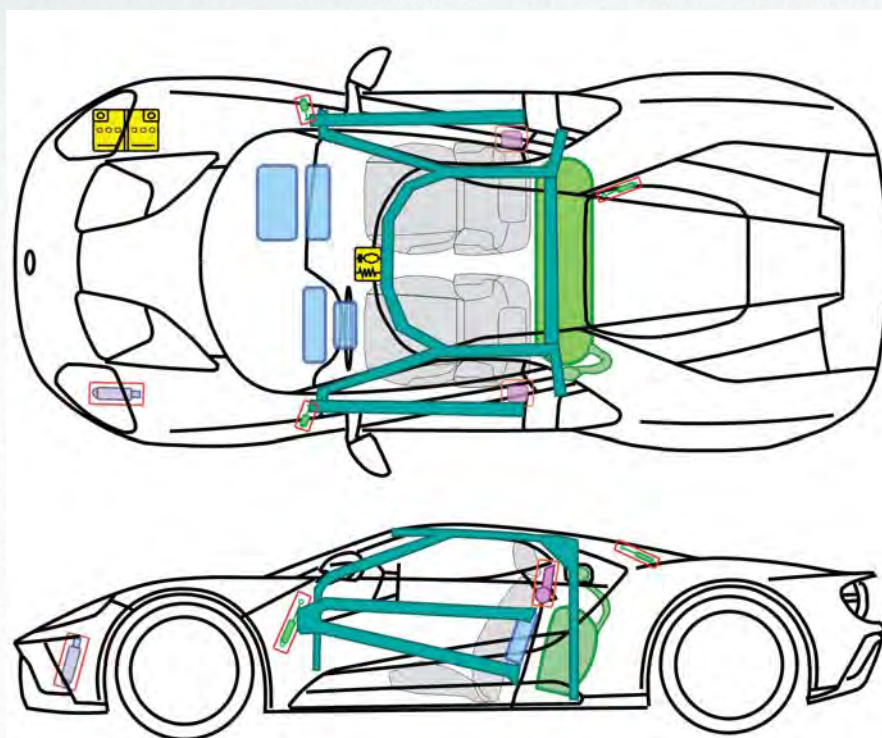

E289972

## Epígrafe

**G**

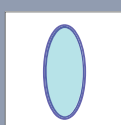

Airbag

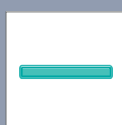

Refuerzos estructurales



Unidad de control



Sistema de protección de los peatones



Generador de gas



Protección antivuelco activa

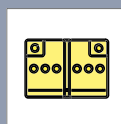

Batería

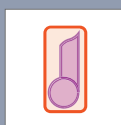

Tensor del cinturón de seguridad

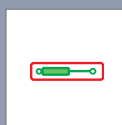

Dispositivo llenado de gas



Depósito de combustible

(Fecha De Publicacion: : 12/2018)



# FORD SERVICE

Tarjetas de rescate

FORD **KA**

08/2008 - >

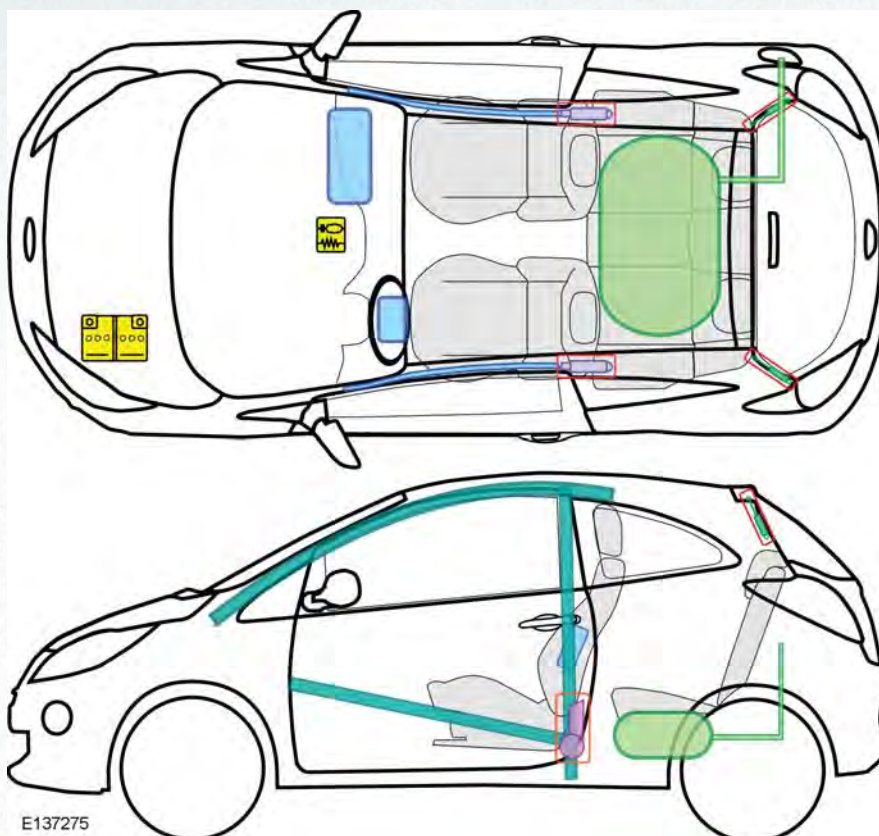

Epígrafe

**K**

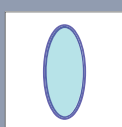

Airbag

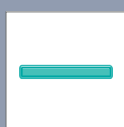

Refuerzos estructurales



Unidad de control



Sistema de protección de los peatones



Generador de gas



Protección antivuelco activa

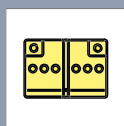

Batería

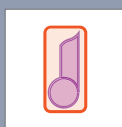

Tensor del cinturón de seguridad

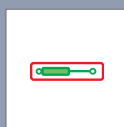

Dispositivo llenado de gas

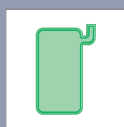

Depósito de combustible

(Fecha De Publicacion: : 01/2011)



# FORD SERVICE

Tarjetas de rescate

## FORD KA

09/1996 – 07/2008

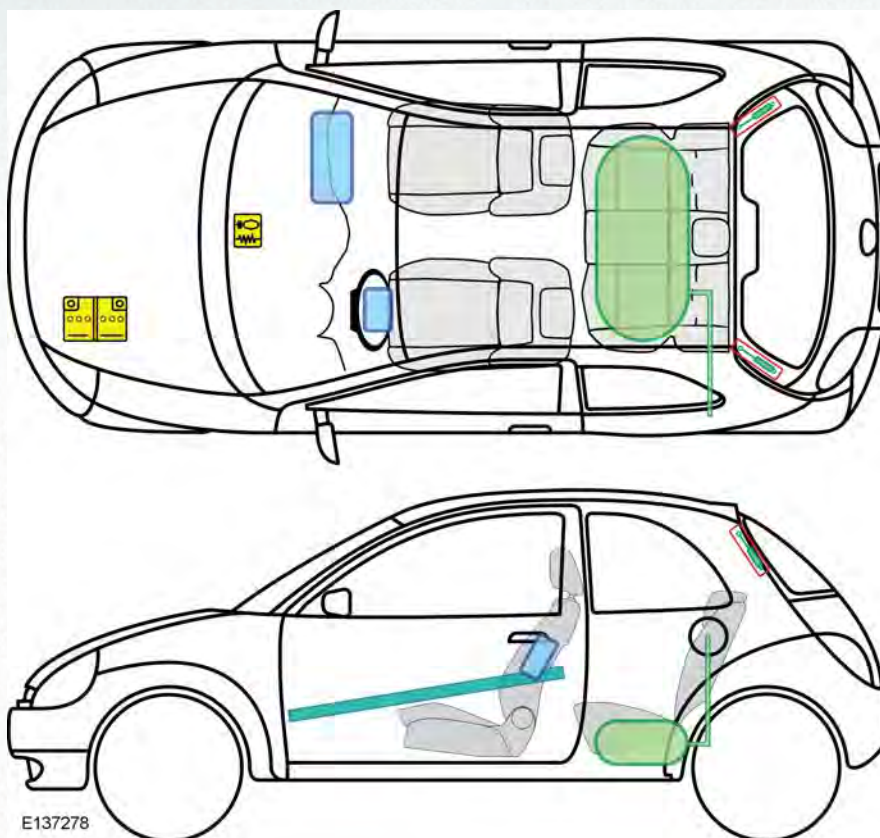
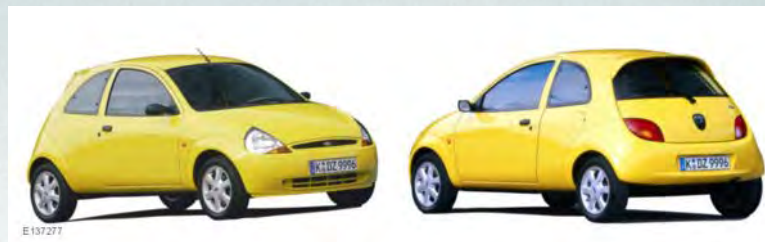

E137278

### Epígrafe

**K**

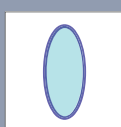

Airbag



Refuerzos estructurales



Unidad de control



Sistema de protección de los peatones



Generador de gas



Protección antivuelco activa

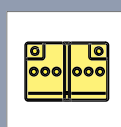

Batería

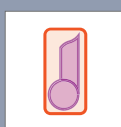

Tensor del cinturón de seguridad



Dispositivo llenado de gas

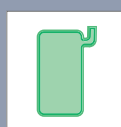

Depósito de combustible

(Fecha De Publicacion: : 01/2011)



# FORD SERVICE

Tarjetas de rescate

FORD **Ka+**

05/2016 – >

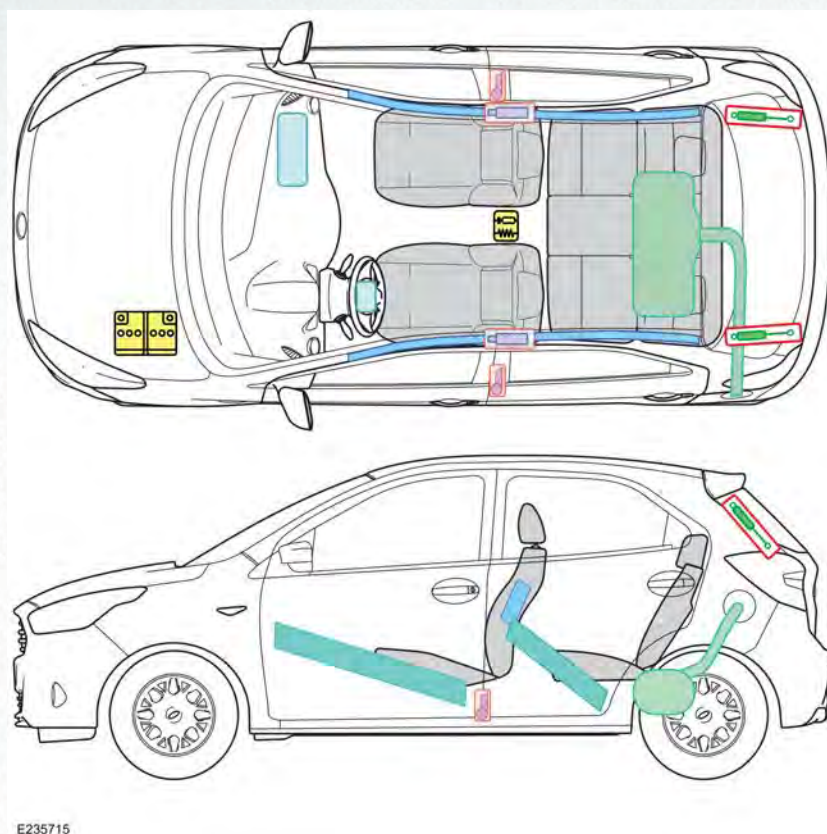

E235715

## Epígrafe

**K**

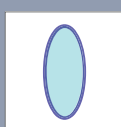

Airbag

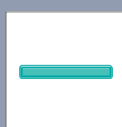

Refuerzos estructurales



Unidad de control



Sistema de protección de los peatones



Generador de gas



Protección antivuelco activa

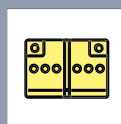

Batería

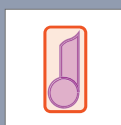

Tensor del cinturón de seguridad

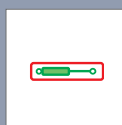

Dispositivo llenado de gas



Depósito de combustible

(Fecha De Publicacion: : 10/2016)



# FORD SERVICE

Tarjetas de rescate

## FORD Kuga

02/2008 – 10/2012

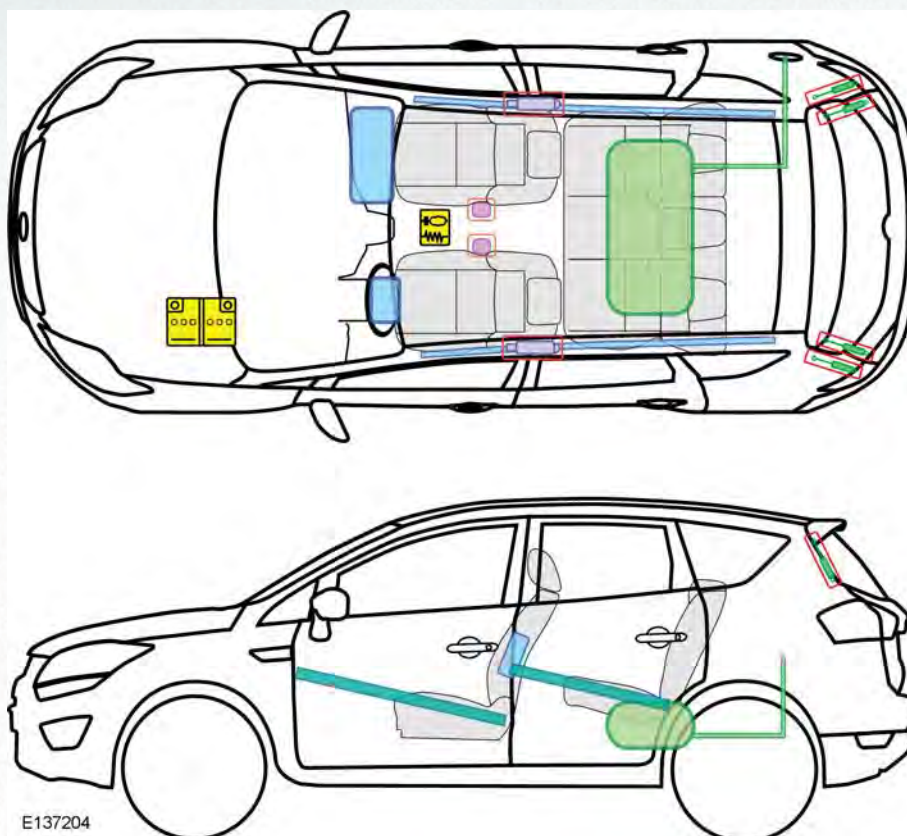

E137204

### Epígrafe

**K**

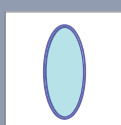

Airbag

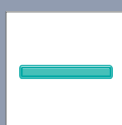

Refuerzos estructurales



Unidad de control



Sistema de protección de los peatones



Generador de gas



Protección antivuelco activa

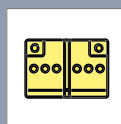

Batería

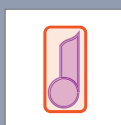

Tensor del cinturón de seguridad

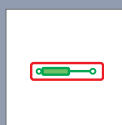

Dispositivo llenado de gas



Depósito de combustible

(Fecha De Publicacion: : 10/2012)



# FORD SERVICE

Tarjetas de rescate

## FORD Kuga

10/2012 – >



E161728

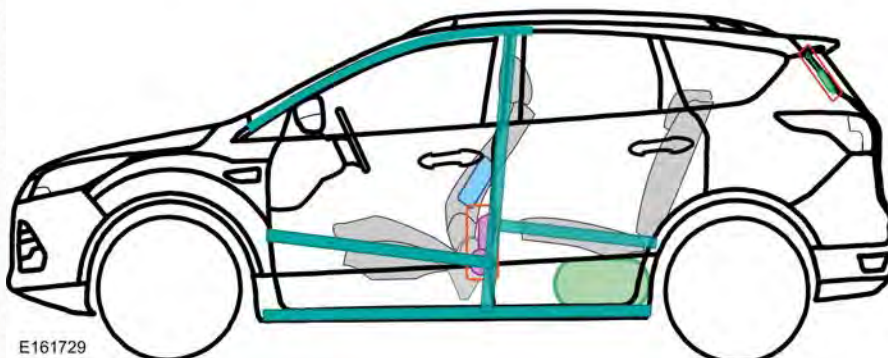
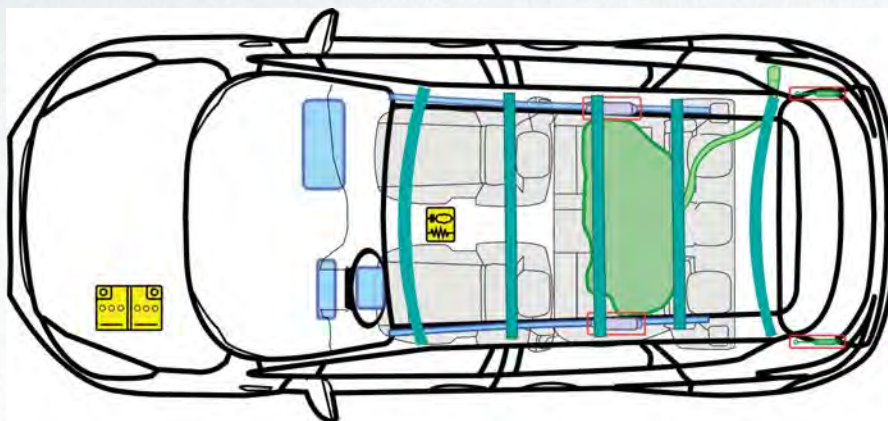

E161729

### Epígrafe

**K**

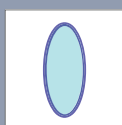

Airbag

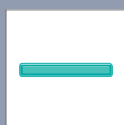

Refuerzos estructurales



Unidad de control



Sistema de protección de los peatones

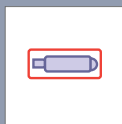

Generador de gas



Protección antivuelco activa

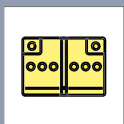

Batería

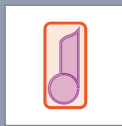

Tensor del cinturón de seguridad

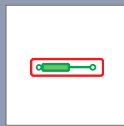

Dispositivo llenado de gas



Depósito de combustible

(Fecha De Publicacion: : 04/2013)





# FORD SERVICE

Tarjetas de rescate

## FORD Kuga

07/2019 – >



E323867

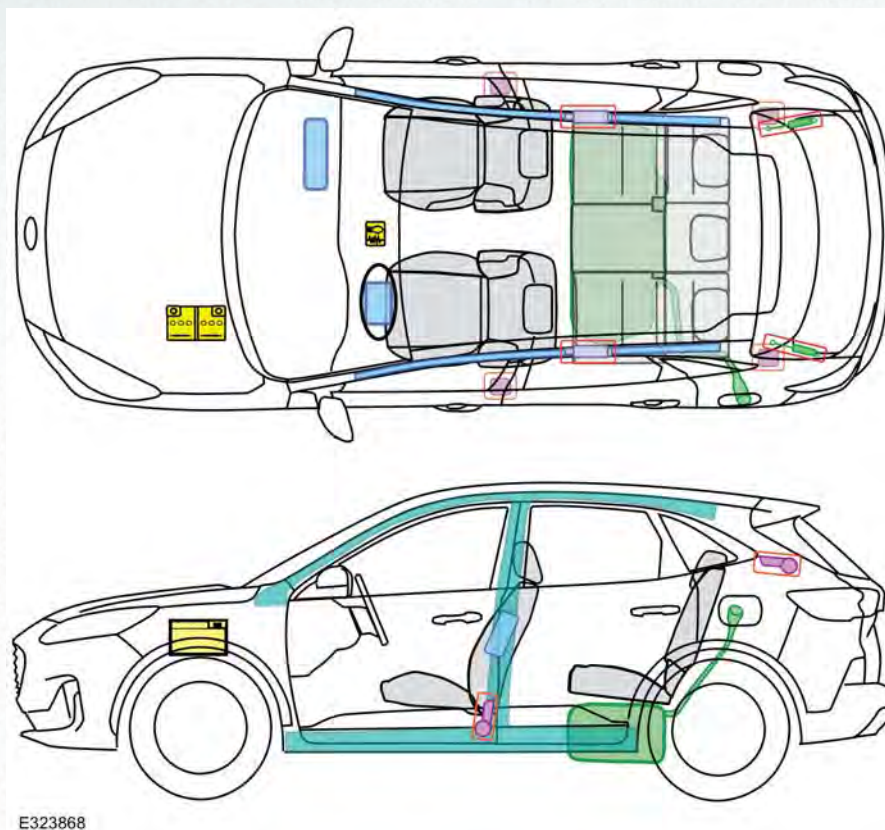

E323868

### Epígrafe

**K**

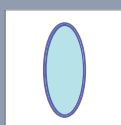

Airbag

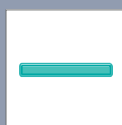

Refuerzos estructurales



Unidad de control



Sistema de protección de los peatones



Generador de gas



Protección antivuelco activa

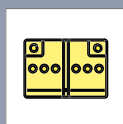

Batería

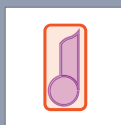

Tensor del cinturón de seguridad

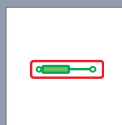

Dispositivo llenado de gas



Depósito de combustible

(Fecha De Publicacion: : 03/2020)



# FORD SERVICE

Tarjetas de rescate

## FORD Kuga mHEV

06/2019 – >

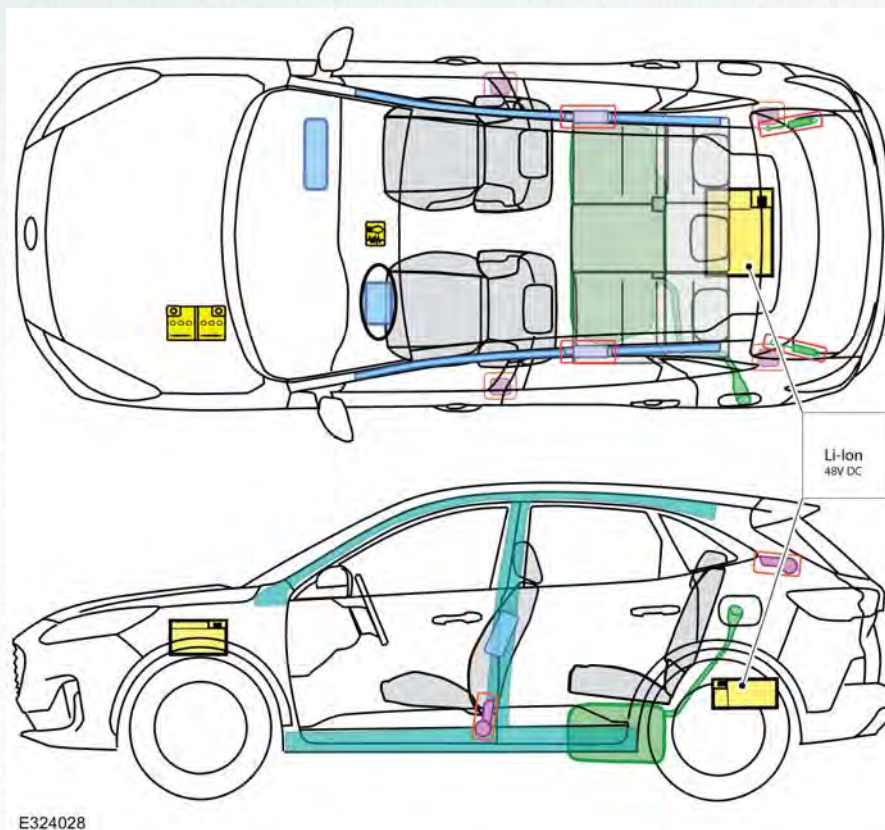

E324028

### Epígrafe

**K**

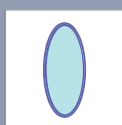

Airbag

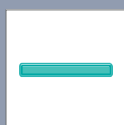

Refuerzos estructurales



Unidad de control



Sistema de protección de los peatones



Generador de gas



Protección antivuelco activa

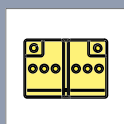

Batería

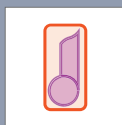

Tensor del cinturón de seguridad

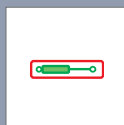

Dispositivo llenado de gas



Depósito de combustible

(Fecha De Publicacion: : 03/2020)



# FORD SERVICE

Tarjetas de rescate

## FORD Kuga PHEV

2,5l Duratec – Híbrido (121 kW/164CV)  
(BG)

06/2019 – >

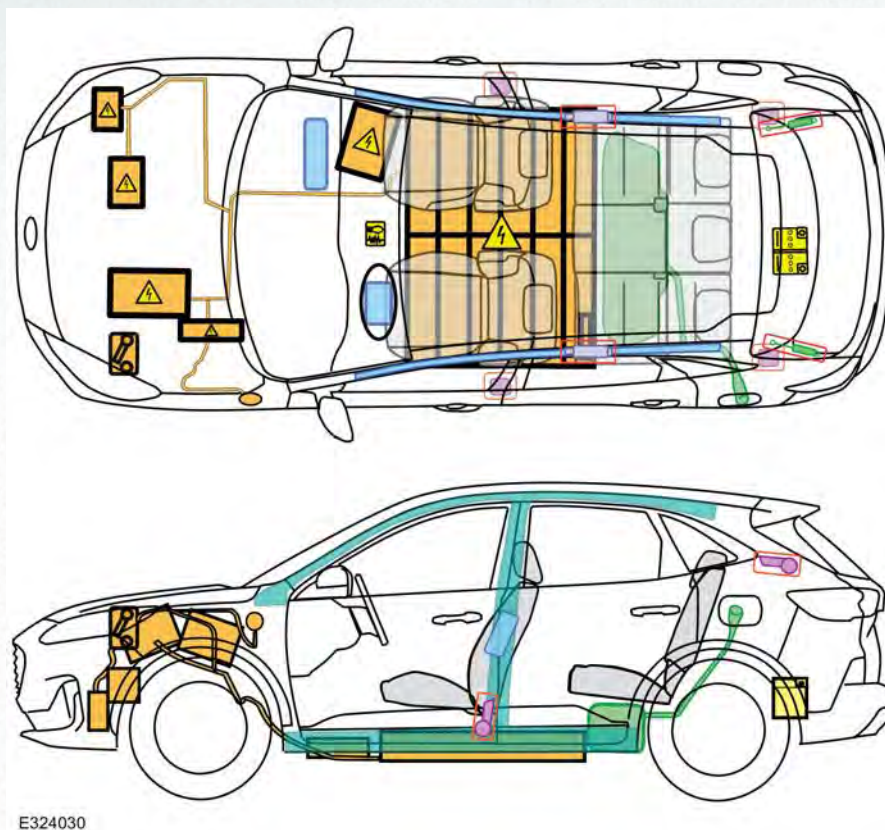

E324030

### Epígrafe

**K**

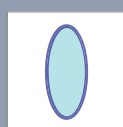

Airbag

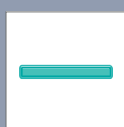

Refuerzos estructurales

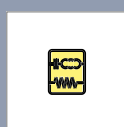

Unidad de control



Sistema de protección de los peatones



Generador de gas

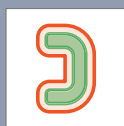

Protección antivuelco activa

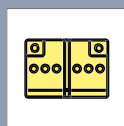

Batería

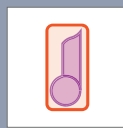

Tensor del cinturón de seguridad

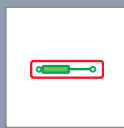

Dispositivo llenado de gas

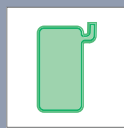

Depósito de combustible

(Fecha De Publicacion: : 06/2020)



## IDENTIFICACIÓN DEL VEHÍCULO ELÉCTRICO

### Identificación por las características del vehículo



E324250

1. Puerto de carga de alta tensión

## Identificación por las características del vehículo



E324243



### 1. Distintivo de vehículo híbrido

## Desactivación del sistema de alta tensión

**¡TENGA EN CUENTA SIEMPRE QUE EL SISTEMA DE ALTA TENSIÓN DEL VEHÍCULO ESTÁ ENCENDIDO! ANTES DE ACCEDER AL VEHÍCULO, ASEGÚRESE DE QUE TODAS LAS ALIMENTACIONES ELÉCTRICAS EXTERNAS ESTÁN DESCONECTADAS (EJ.: CARGADOR ELÉCTRICO, HERRAMIENTAS ELÉCTRICAS). Si no se respetan estas advertencias, se pueden producir lesiones graves o incluso provocar la muerte.**

## FUNCIONES DE DESCONEXIÓN ELÉCTRICA DE ALTA TENSIÓN

### AVISOS:

-  Si desmonta la desconexión del servicio, se desconectará la alta tensión del vehículo. El paquete de la batería de alta tensión permanecerá activo y peligroso. No desconecte la carcasa de la batería de alta tensión. No manipule de ninguna manera el interior de las baterías de alta tensión o de la carcasa. Si es posible, aíse los componentes de alta tensión del vehículo y evite el contacto con ellos.
-  Los daños en los vehículos eléctricos provocados por una colisión pueden poner en peligro los sistemas de seguridad de alta tensión y suponer un posible riesgo de descarga eléctrica de alta

**tensión. Extreme las precauciones y lleve siempre el equipamiento de seguridad del equipo de protección personal adecuado. Quítese todos los accesorios metálicos, incluidos reloj y anillos. Si no se respetan estas advertencias, se pueden producir lesiones graves o incluso provocar la muerte.**

**Encendido en posición de desactivado:** cuando el encendido está en posición de desactivado (y el vehículo no está cargando) el sistema de alta tensión está desactivado.

**Desconexión del servicio:** cuando las desconexiones de servicio se desmontan, el sistema de alta tensión queda desactivado.

### Desactivación del sistema de alta tensión-Método 1

Si no es posible acceder a la batería de 12 V, pase al método 2.

**1. Compruebe si el sistema de alta tensión está recibiendo alimentación.**



# FORD SERVICE

Tarjetas de rescate

## 2. Si el sistema de alta tensión está activo, apague el encendido.



3.

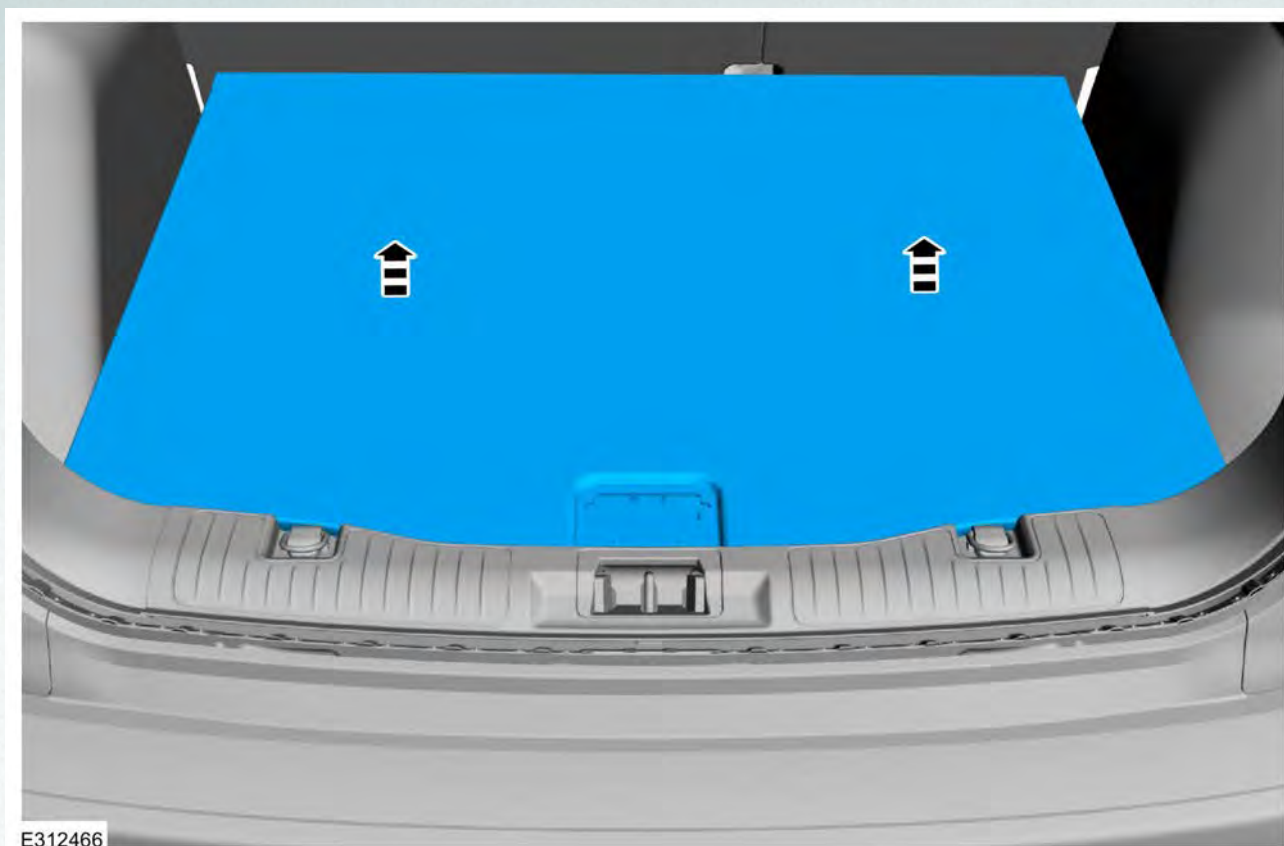

E312466



## 1. Vehículos híbridos con neumático de repuesto

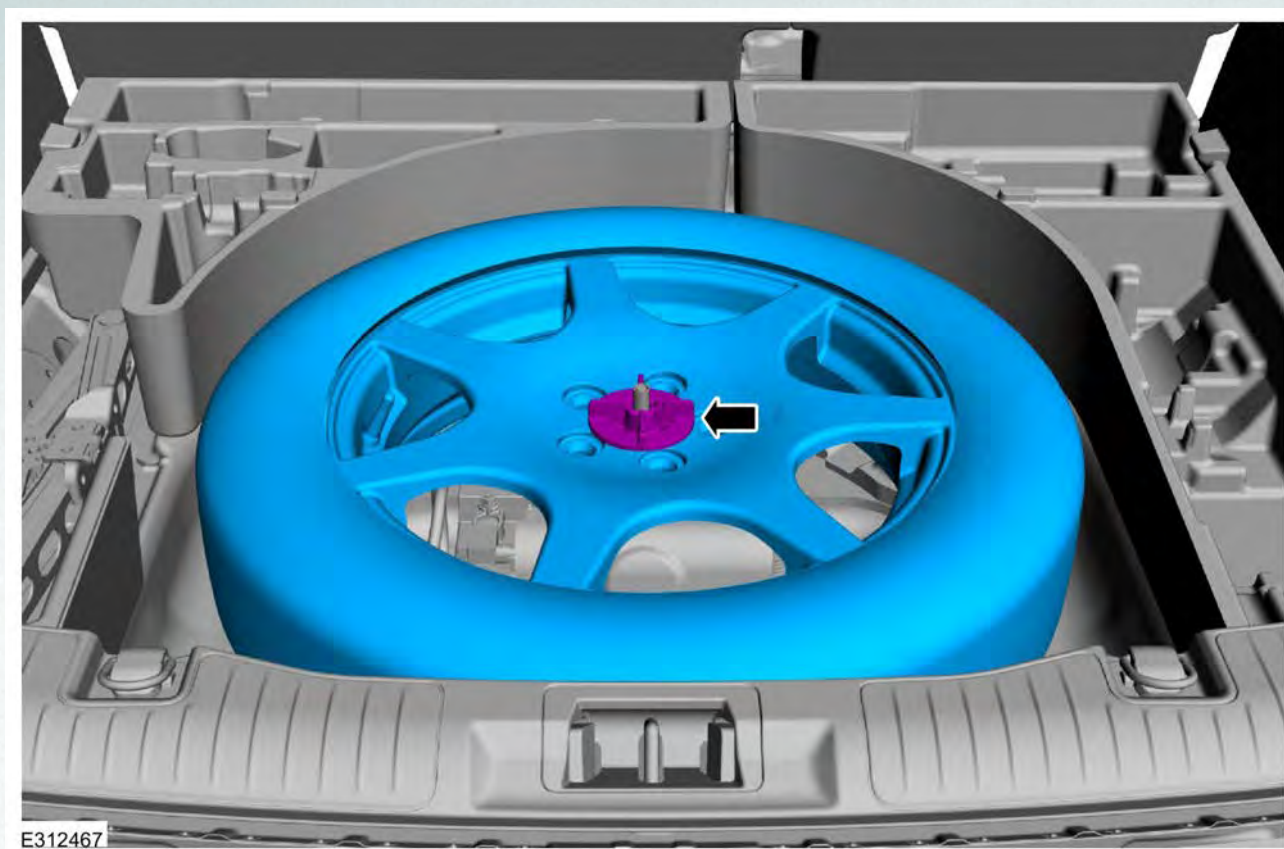

## 2. Desconecte el cable de la batería de 12 V.

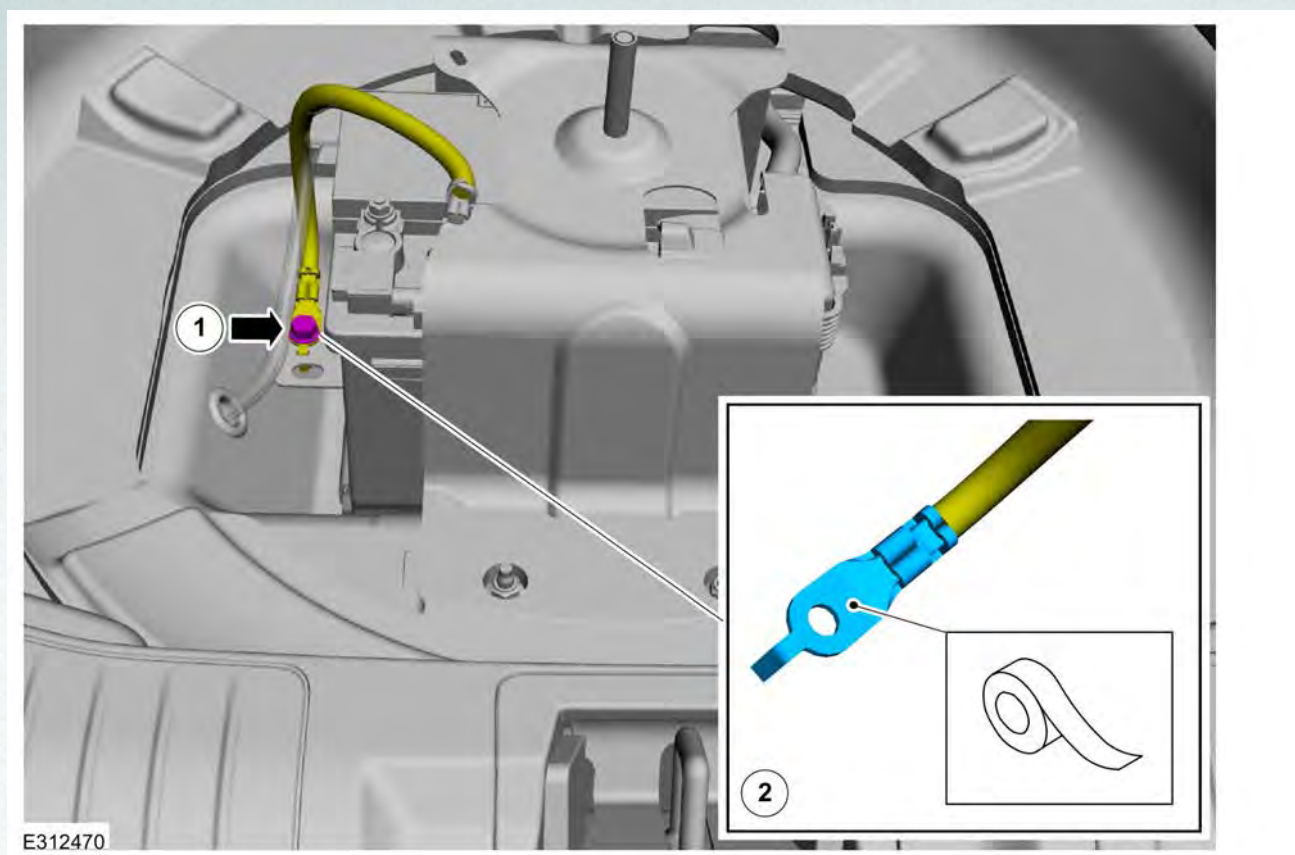

## 3. Vehículos híbridos sin neumático de repuesto

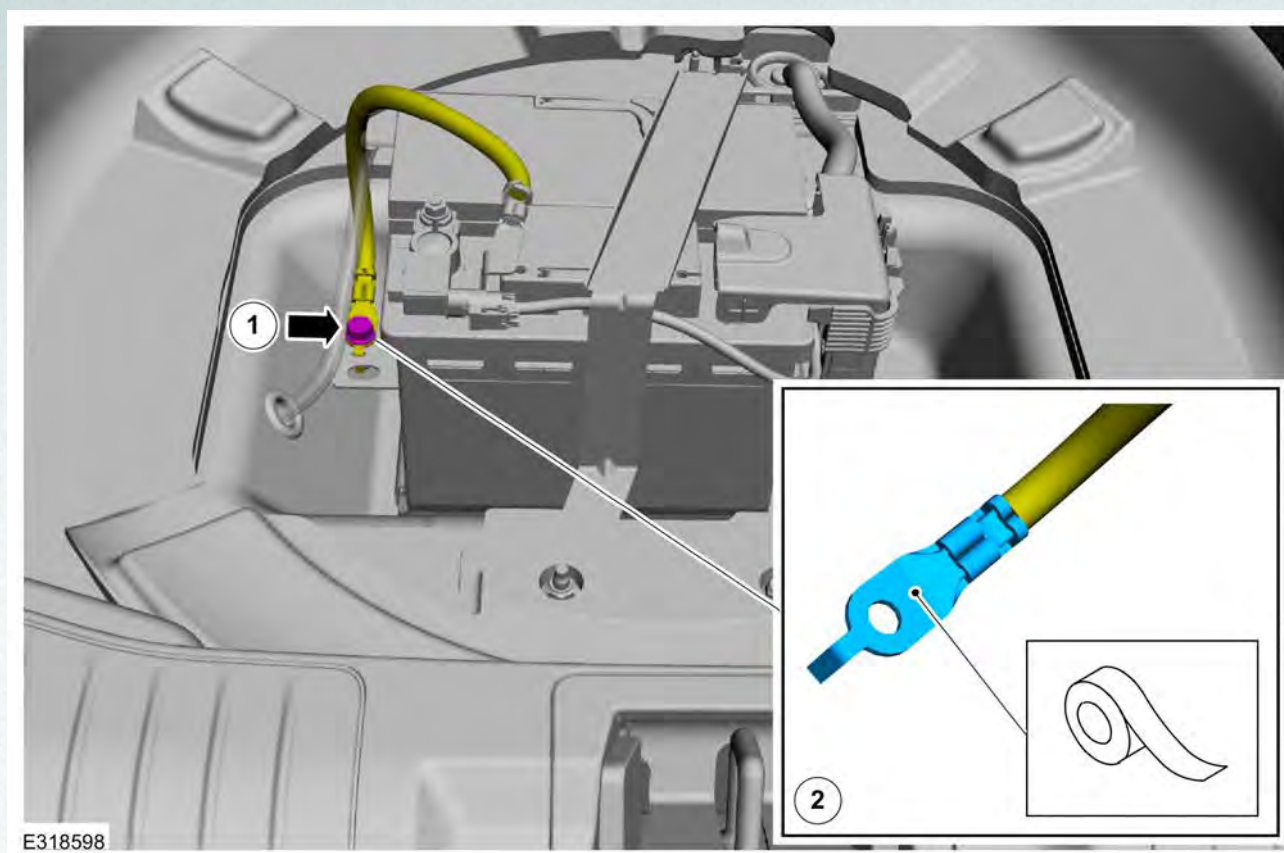

E318598

### Desactivación del sistema de alta tensión-Método 2

El sistema de batería de alta tensión utiliza un conector de desconexión de baja tensión que abre el circuito de alimentación del control del contactor de 12 voltios y se encuentra en el compartimento motor. Cuando se desconecta el conector de desconexión de servicio, los contactores de alta tensión que suministran alta tensión al vehículo no pueden cerrarse.

**1. Abra el capó. No hay ningún pestillo secundario debajo del capó.**

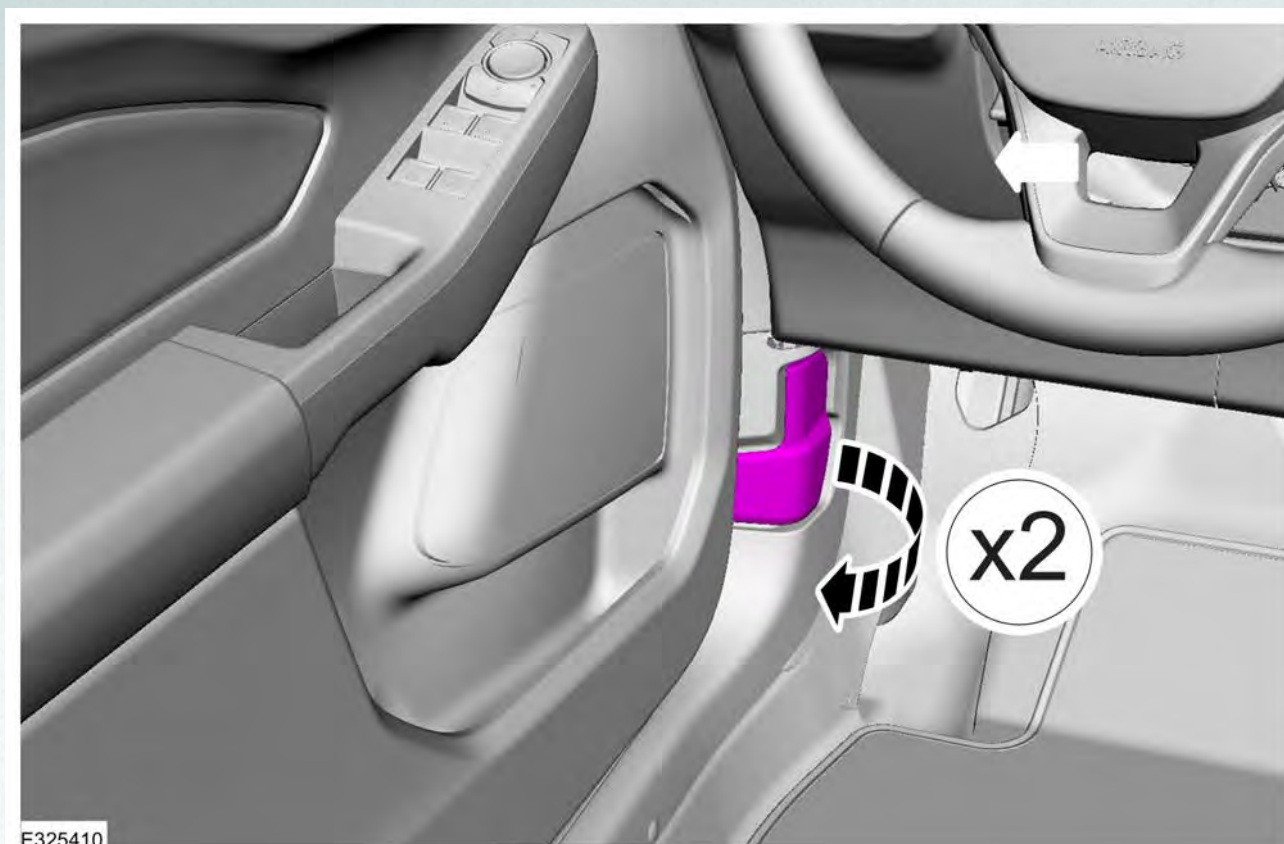

## 2. Ubicación de la desconexión de servicio.

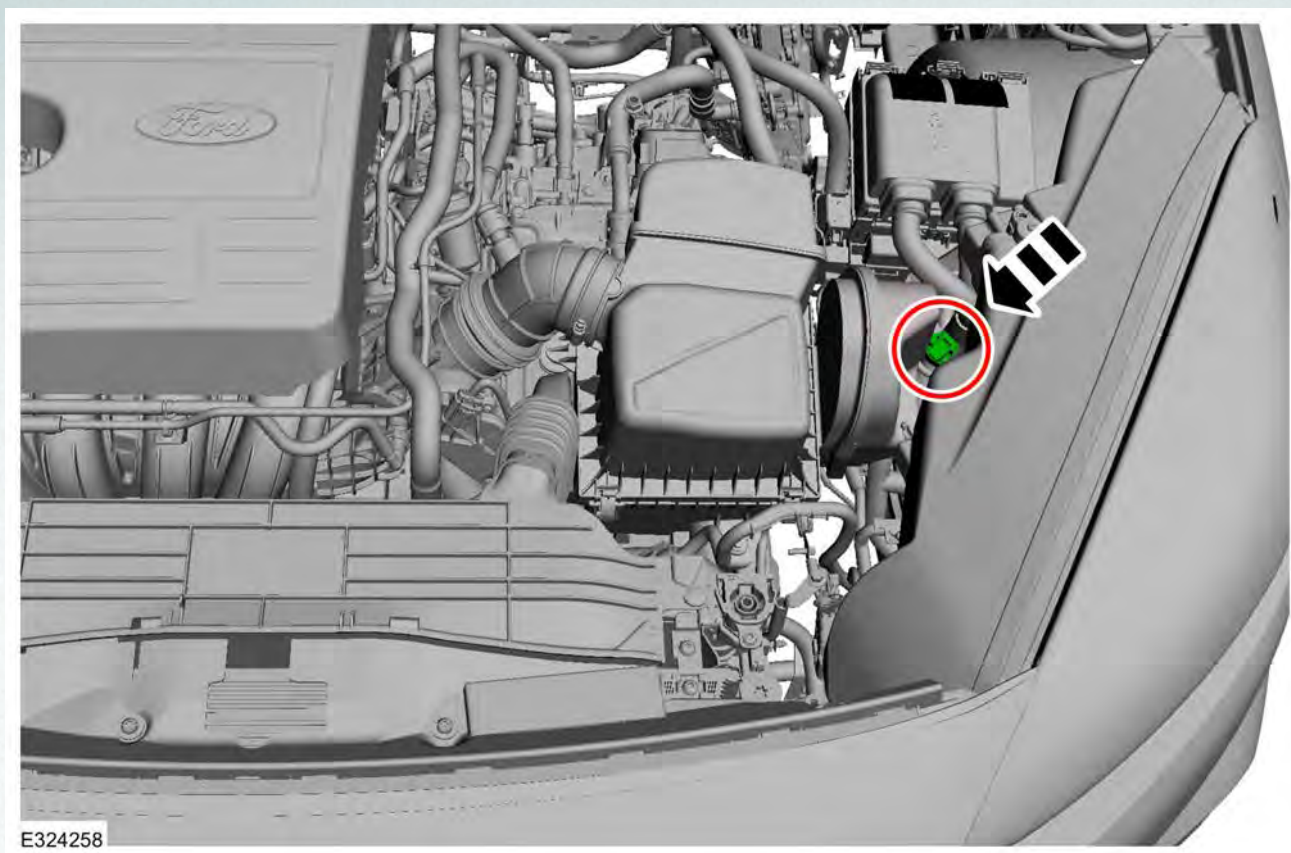

# FORD SERVICE

Tarjetas de rescate

3.

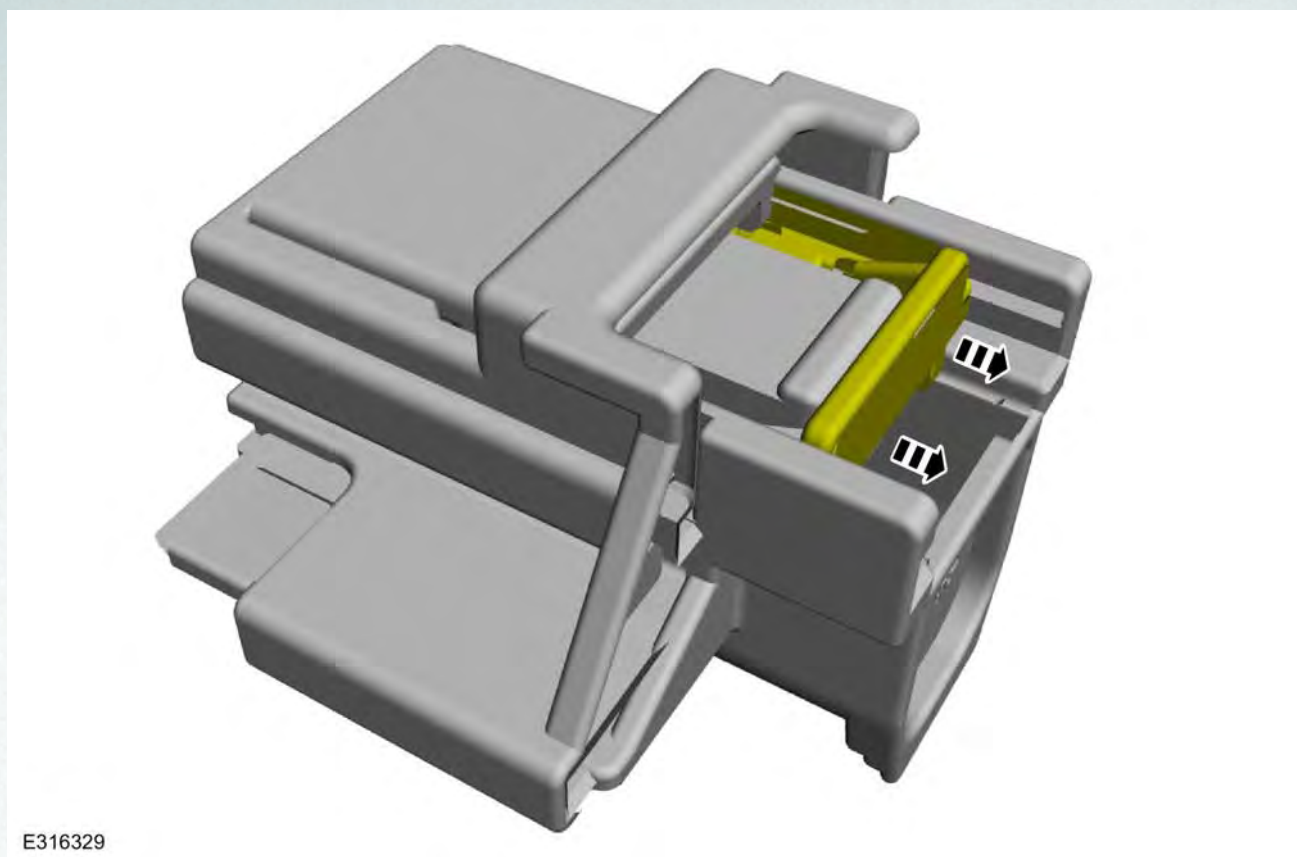

E316329

# FORD SERVICE

Tarjetas de rescate

4. Tire de la parte superior hacia arriba hasta que se vea la palabra "OFF". No es posible desmontar la pieza deslizante de la cabecera.

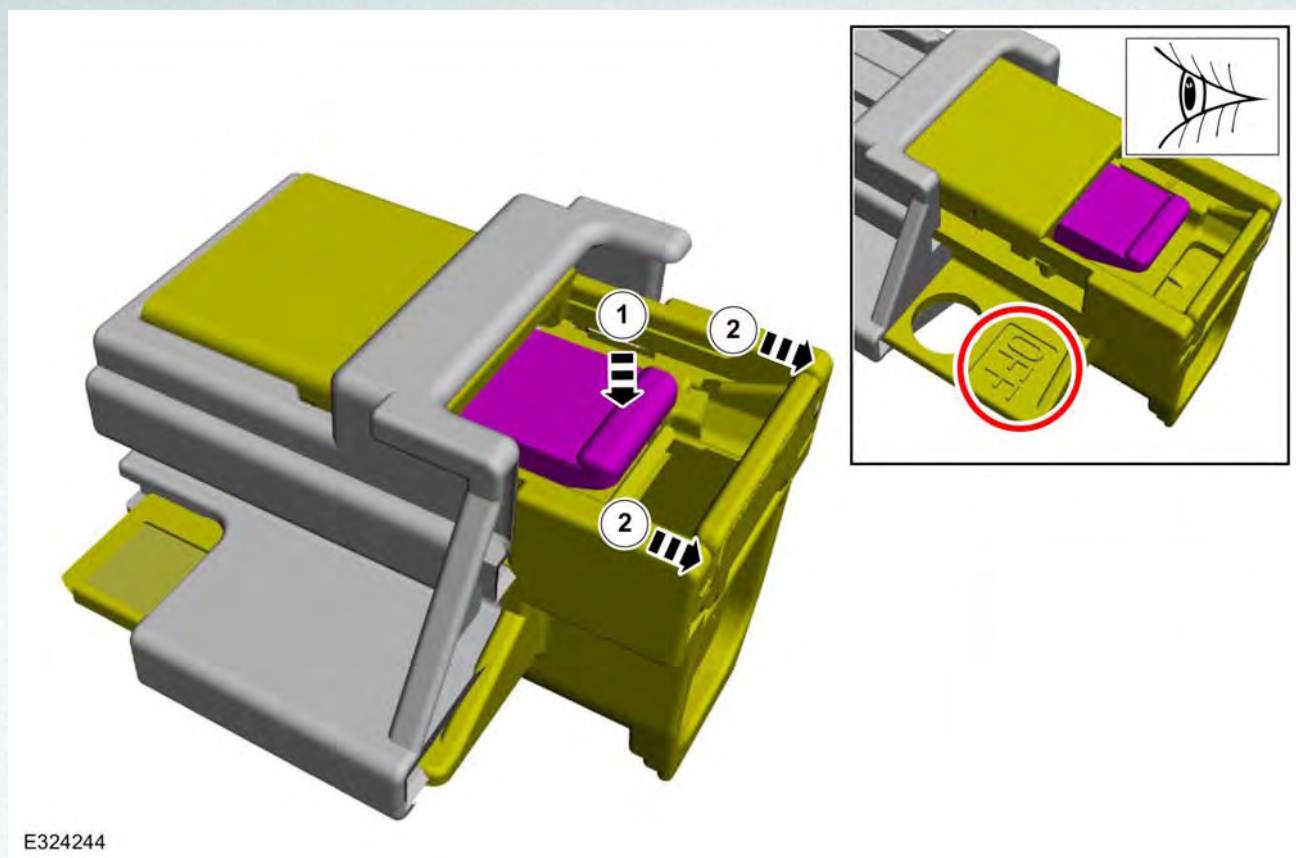

5.

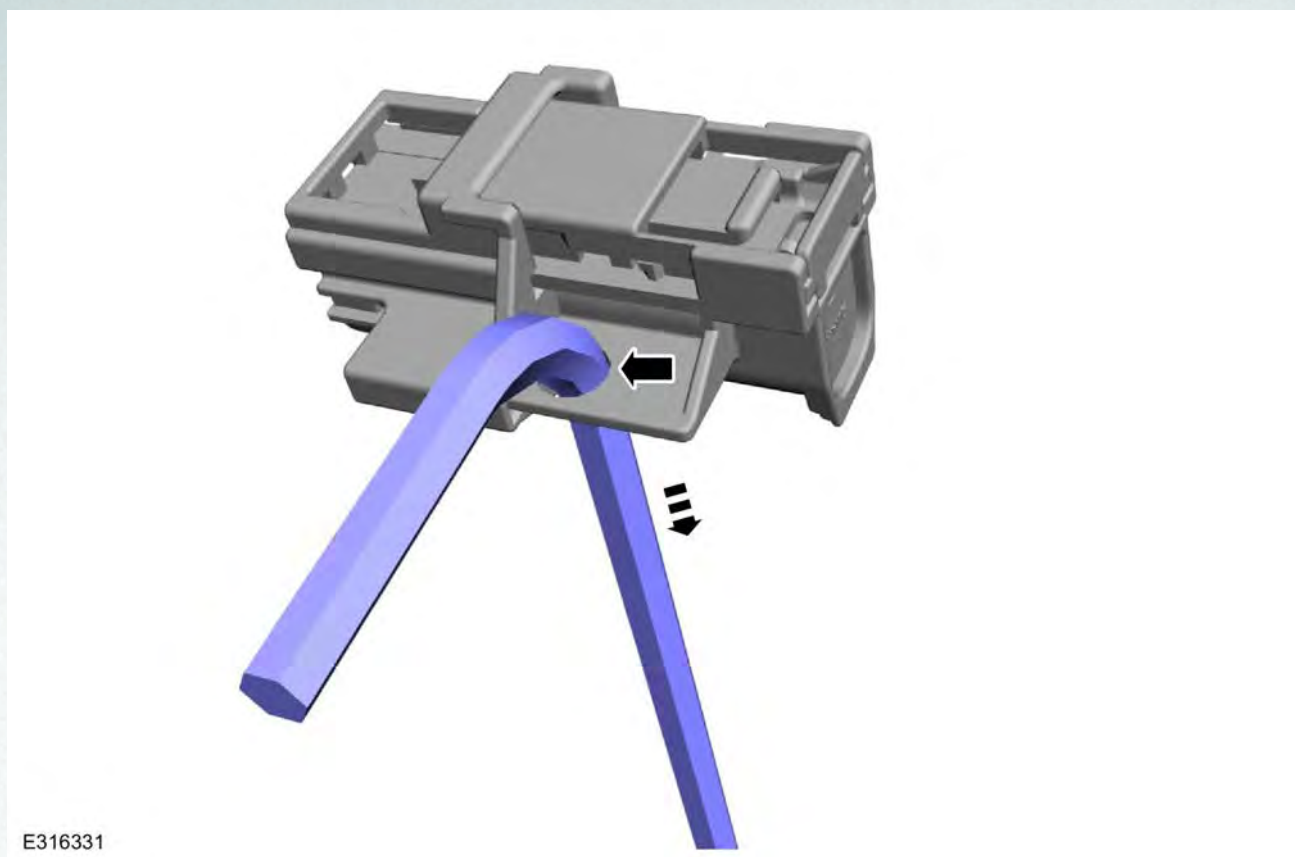

(Fecha De Publicacion: : 06/2020)



# FORD SERVICE

Tarjetas de rescate

## FORD Mondeo

4 puertas

10/2000 – 02/2007

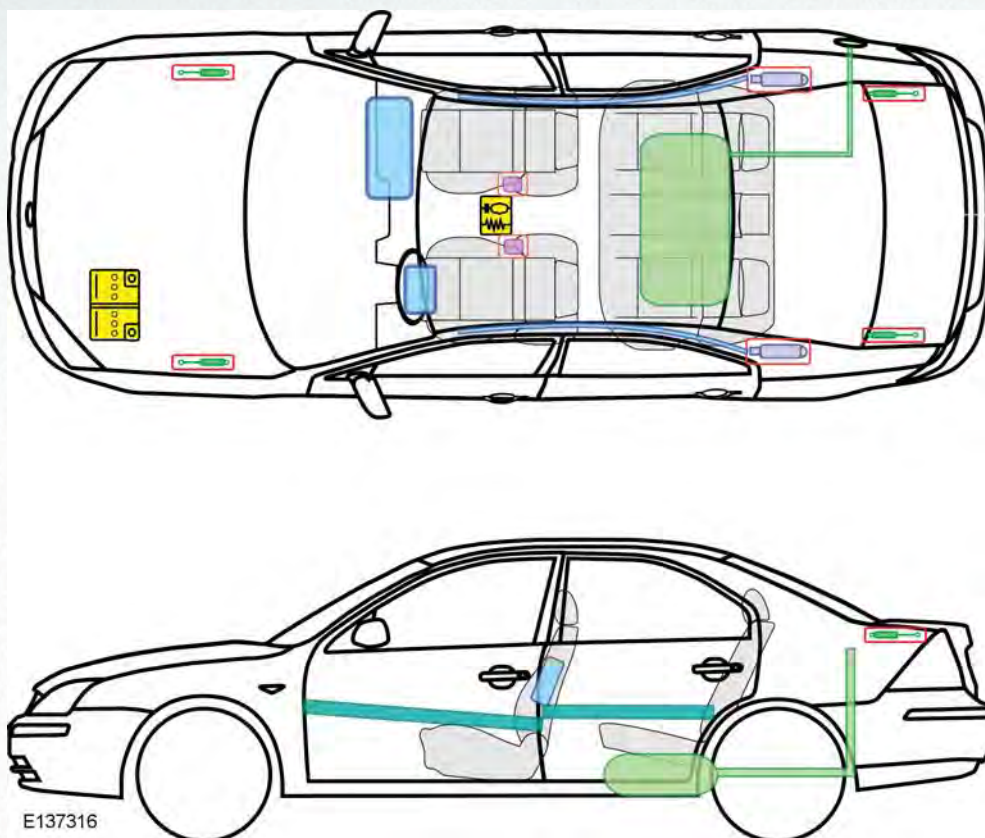

Epígrafe

M

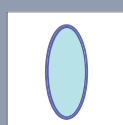

Airbag



Refuerzos estructurales



Unidad de control



Sistema de protección de los peatones



Generador de gas



Protección antivuelco activa

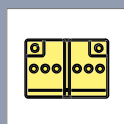

Batería

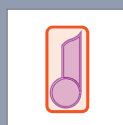

Tensor del cinturón de seguridad

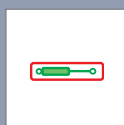

Dispositivo llenado de gas



Depósito de combustible

(Fecha De Publicacion: : 01/2011)



# FORD SERVICE

Tarjetas de rescate

## FORD Mondeo

4 puertas

02/2007 – 09/2014

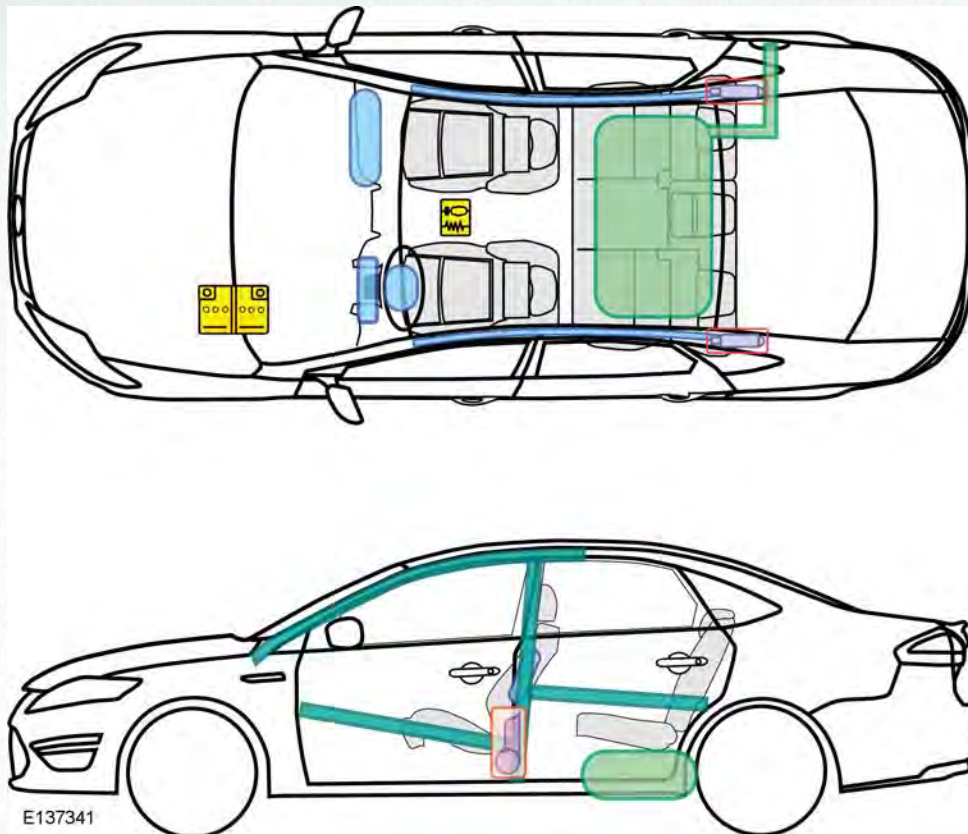

E137341

### Epígrafe

M

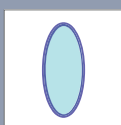

Airbag

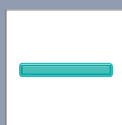

Refuerzos estructurales



Unidad de control



Sistema de protección de los peatones



Generador de gas



Protección antivuelco activa

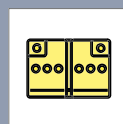

Batería

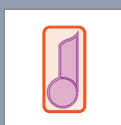

Tensor del cinturón de seguridad

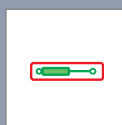

Dispositivo llenado de gas



Depósito de combustible

(Fecha De Publicacion: : 01/2011)



# FORD SERVICE

Tarjetas de rescate

## FORD Mondeo - LPG

4 puertas

02/2007 – 09/2014



E137333

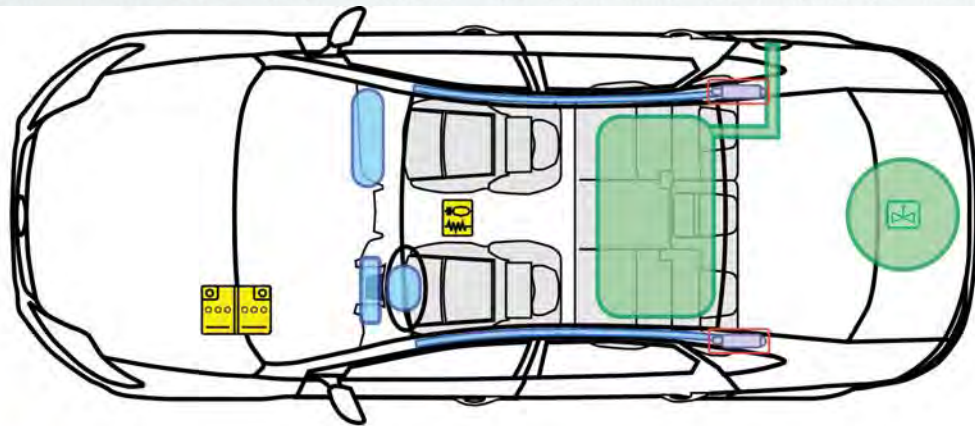

**LPG**

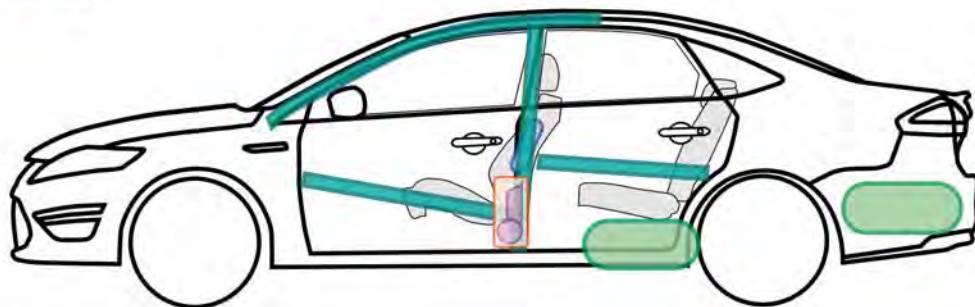

E137339

Epígrafe

**M**

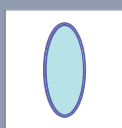

Airbag

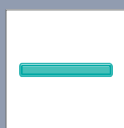

Refuerzos estructurales



Unidad de control



Sistema de protección de los peatones

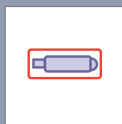

Generador de gas



Protección antivuelco activa

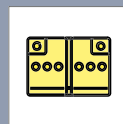

Batería



Depósito de gas

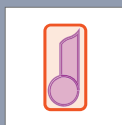

Tensor del cinturón de seguridad

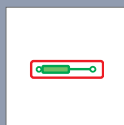

Dispositivo llenado de gas



Depósito de combustible

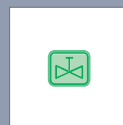

Válvula de seguridad

(Fecha De Publicacion: : 02/2015)



# FORD SERVICE

Tarjetas de rescate

## FORD Mondeo

5 puertas

10/2000 – 02/2007

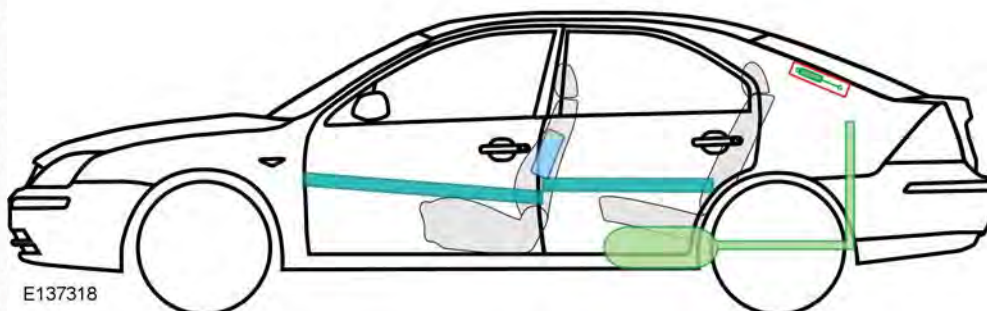
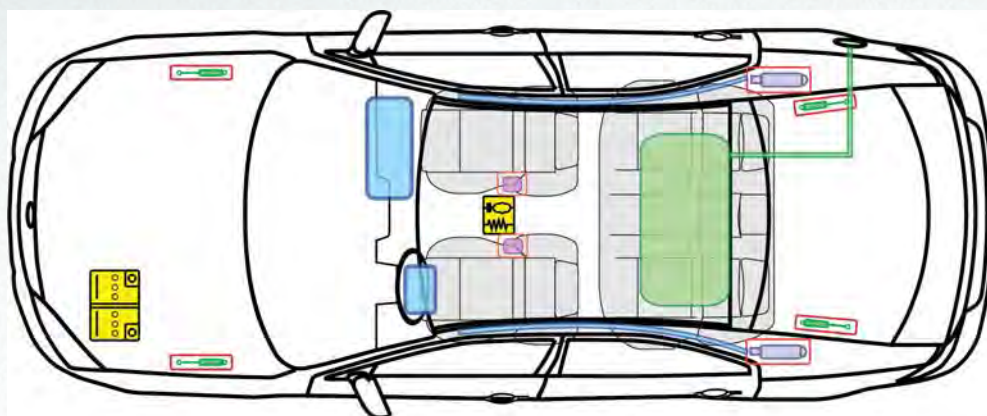

E137318

### Epígrafe

**M**

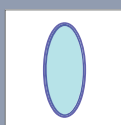

Airbag

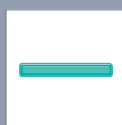

Refuerzos estructurales



Unidad de control



Sistema de protección de los peatones



Generador de gas



Protección antivuelco activa

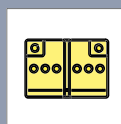

Batería

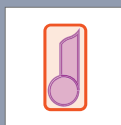

Tensor del cinturón de seguridad

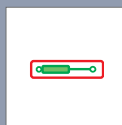

Dispositivo llenado de gas



Depósito de combustible

(Fecha De Publicacion: : 01/2011)



# FORD SERVICE

Tarjetas de rescate

## FORD Mondeo

5 puertas

02/2007 – 09/2014

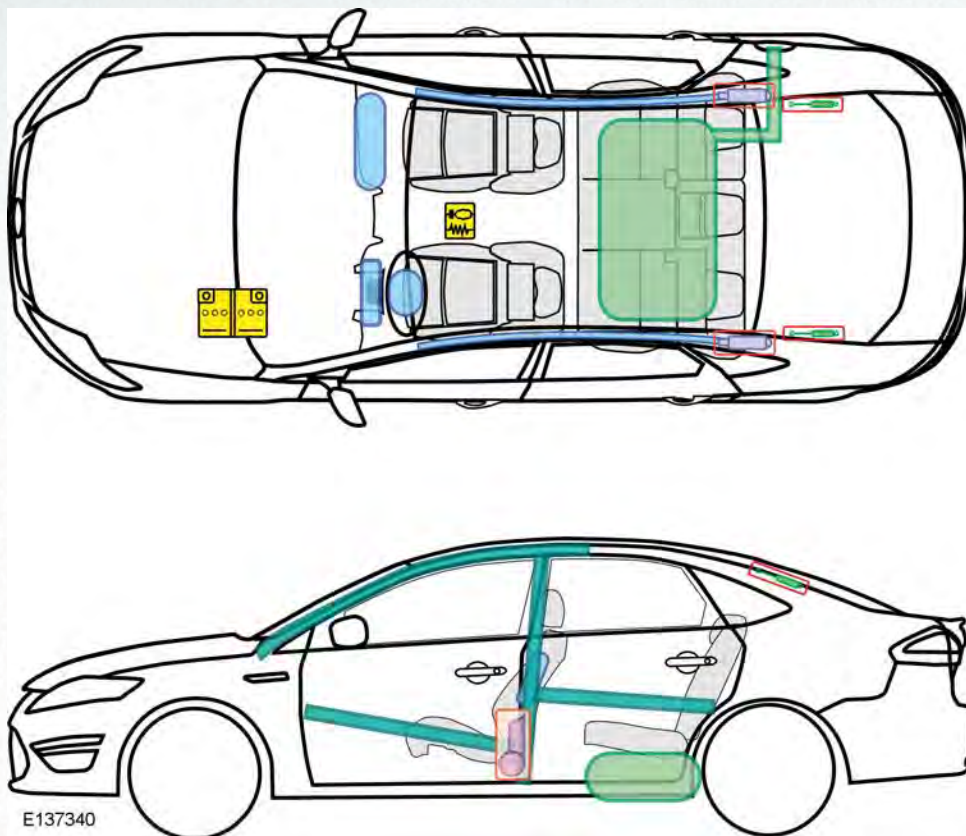

E137340

### Epígrafe

M

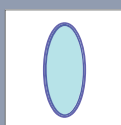

Airbag

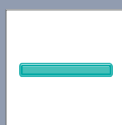

Refuerzos estructurales



Unidad de control



Sistema de protección de los peatones

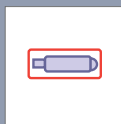

Generador de gas

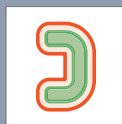

Protección antivuelco activa

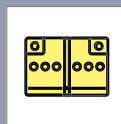

Batería

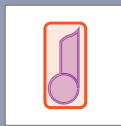

Tensor del cinturón de seguridad

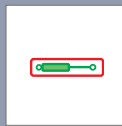

Dispositivo llenado de gas



Depósito de combustible

(Fecha De Publicacion: : 01/2011)



# FORD SERVICE

Tarjetas de rescate

## FORD Mondeo

5 puertas

09/2014 – >





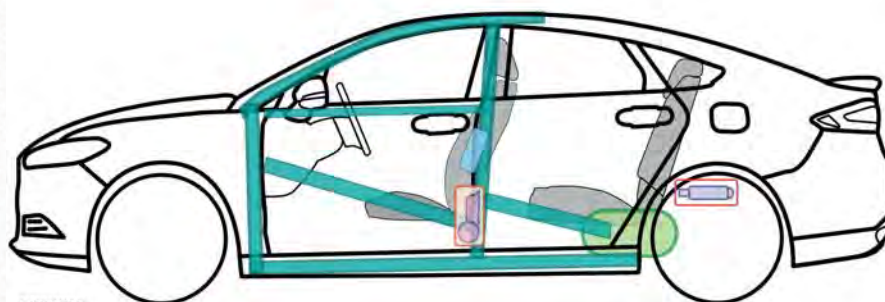
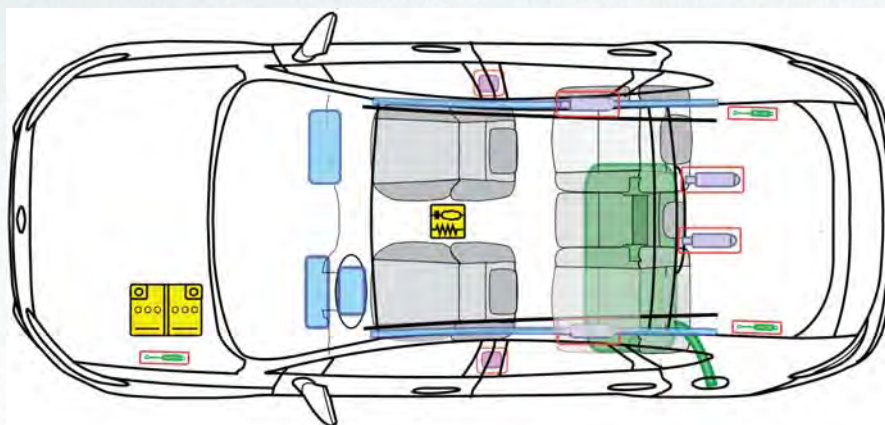



E199377

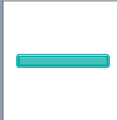

E203215

### Epígrafe

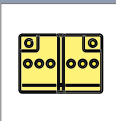
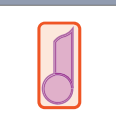
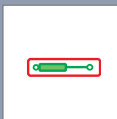
M

	Airbag		Refuerzos estructurales		Unidad de control		Sistema de protección de los peatones
	Generador de gas		Protección antivuelco activa		Batería		
	Tensor del cinturón de seguridad		Dispositivo llenado de gas		Depósito de combustible		

(Fecha De Publicacion: : 05/2015)



# FORD SERVICE

Tarjetas de rescate

## FORD Mondeo - LPG

5 puertas

02/2007 – 09/2014



E137333

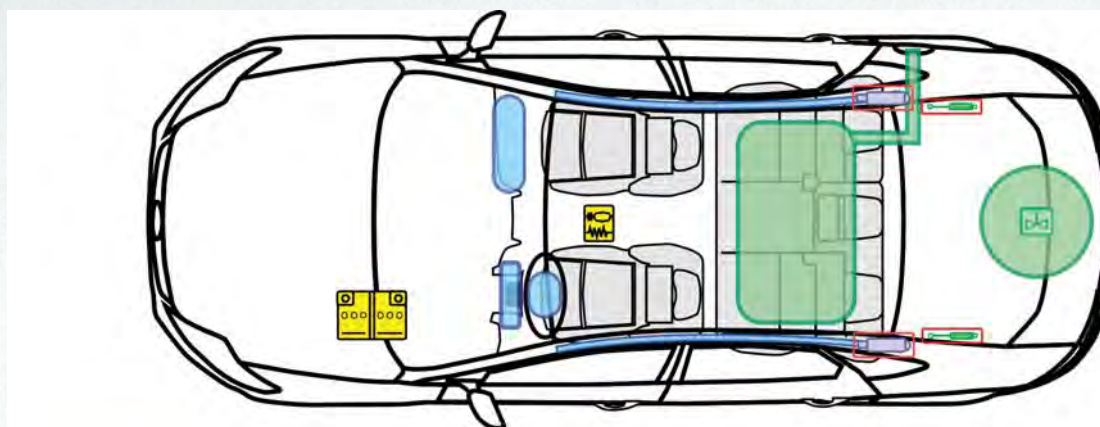

**LPG**

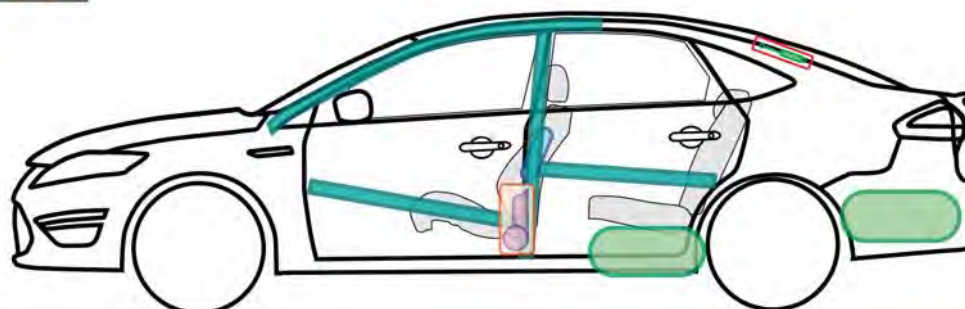

E137337

Epígrafe

**M**

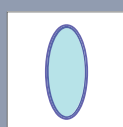

Airbag



Refuerzos estructurales



Unidad de control



Sistema de protección de los peatones



Generador de gas



Protección antivuelco activa

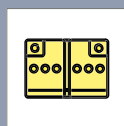

Batería



Depósito de gas

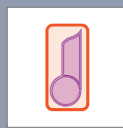

Tensor del cinturón de seguridad

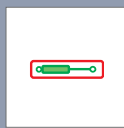

Dispositivo llenado de gas

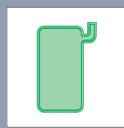

Depósito de combustible

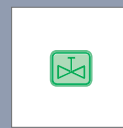

Válvula de seguridad

(Fecha De Publicacion: : 02/2015)



# FORD SERVICE

Tarjetas de rescate

## FORD **Mondeo**

Familiar

10/2000 – 02/2007

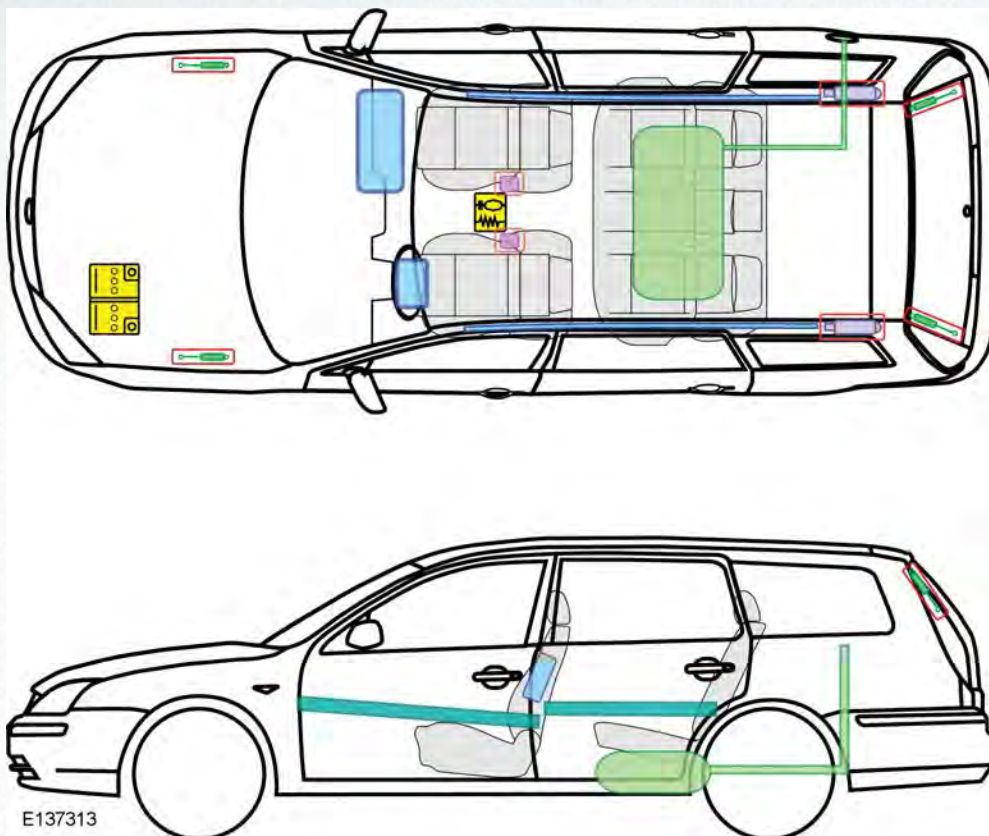

E137313

### Epígrafe

**M**

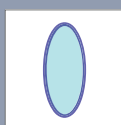

Airbag

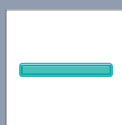

Refuerzos estructurales



Unidad de control



Sistema de protección de los peatones



Generador de gas



Protección antivuelco activa

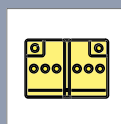

Batería

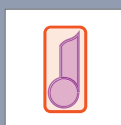

Tensor del cinturón de seguridad

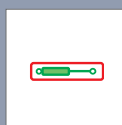

Dispositivo llenado de gas



Depósito de combustible

(Fecha De Publicacion: : 01/2011)





# FORD SERVICE

Tarjetas de rescate

## FORD **Mondeo**

Familiar

02/2007 – 09/2014



E137327

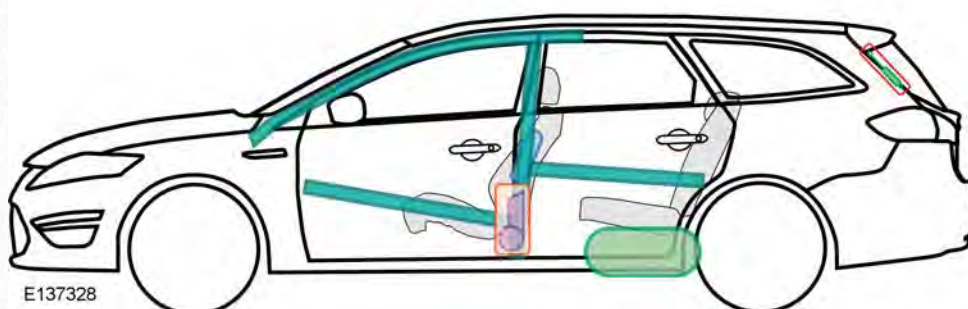
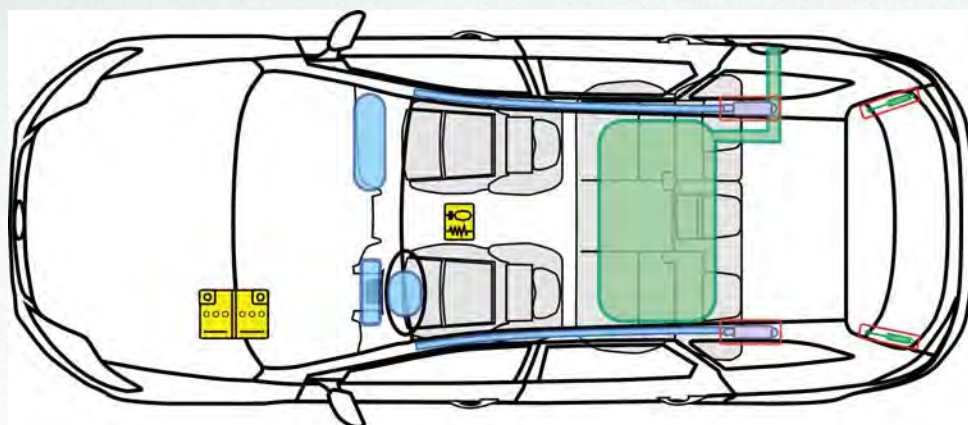

E137328

### Epígrafe

**M**

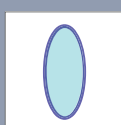

Airbag



Refuerzos estructurales



Unidad de control



Sistema de protección de los peatones



Generador de gas



Protección antivuelco activa

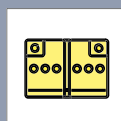

Batería

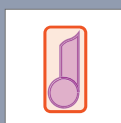

Tensor del cinturón de seguridad

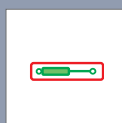

Dispositivo llenado de gas



Depósito de combustible

(Fecha De Publicacion: : 01/2011)



# FORD SERVICE

Tarjetas de rescate

## FORD Mondeo

Familiar

09/2014 – >



E203689

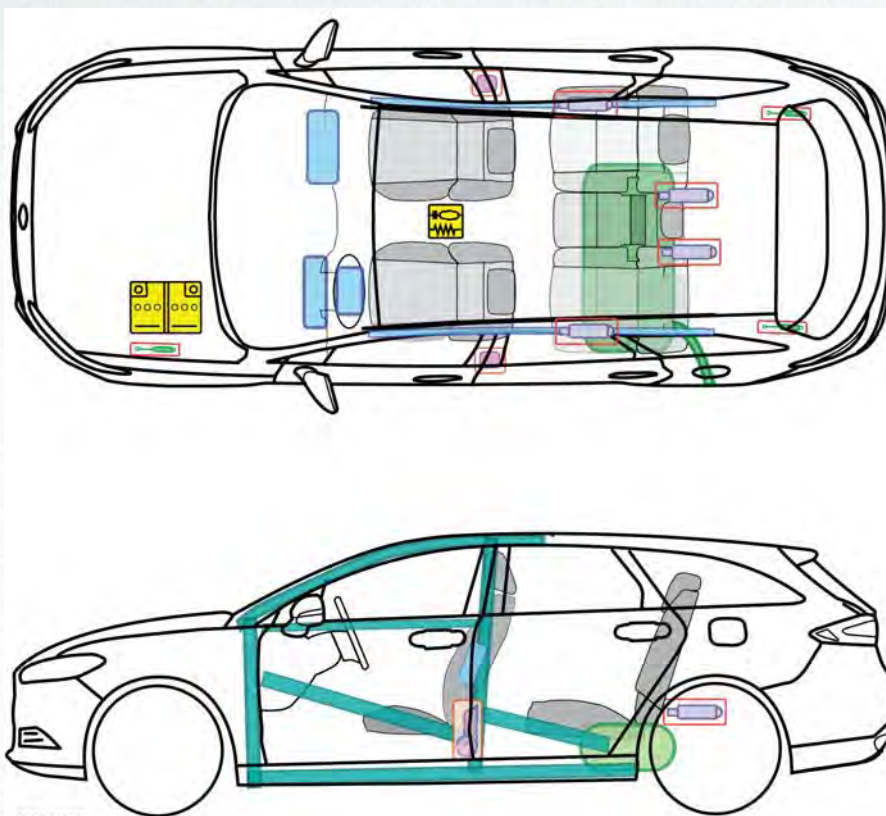

E203688

### Epígrafe

M

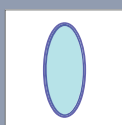

Airbag

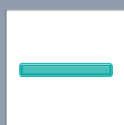

Refuerzos estructurales



Unidad de control



Sistema de protección de los peatones



Generador de gas



Protección antivuelco activa

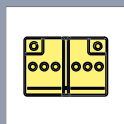

Batería

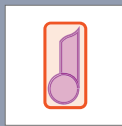

Tensor del cinturón de seguridad

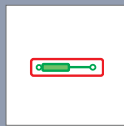

Dispositivo llenado de gas



Depósito de combustible

(Fecha De Publicacion: : 01/2015)



# FORD SERVICE

Tarjetas de rescate

## FORD Mondeo - LPG

Familiar

02/2007 – 09/2014



E137327

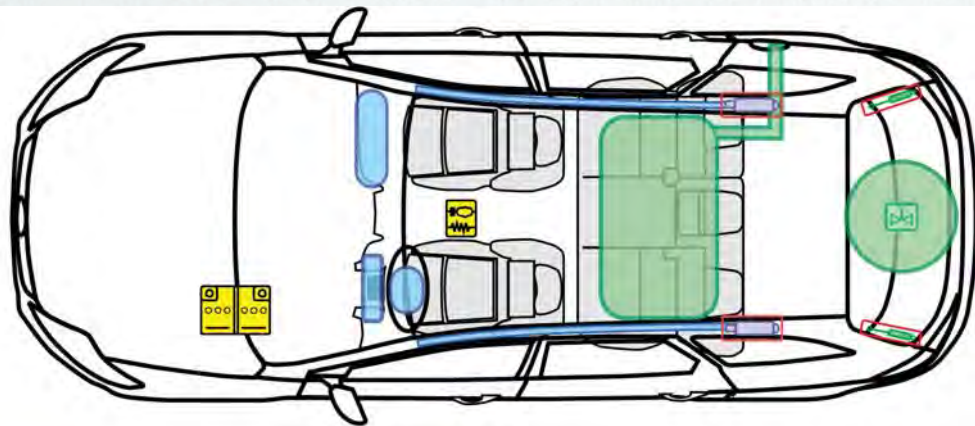

**LPG**

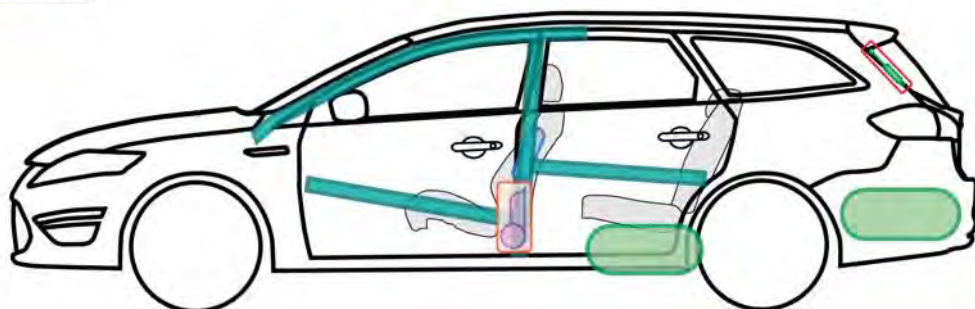

E137334

Epígrafe

**M**

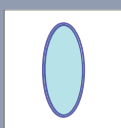

Airbag

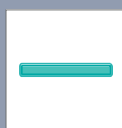

Refuerzos estructurales



Unidad de control



Sistema de protección de los peatones

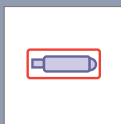

Generador de gas



Protección antivuelco activa

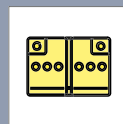

Batería



Depósito de gas

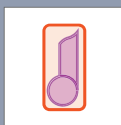

Tensor del cinturón de seguridad

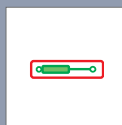

Dispositivo llenado de gas



Depósito de combustible

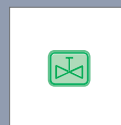

Válvula de seguridad

(Fecha De Publicacion: : 02/2015)



# FORD SERVICE

Tarjetas de rescate

## FORD Mondeo "Hybrid" - HEV

4 puertas

10/2014 - >

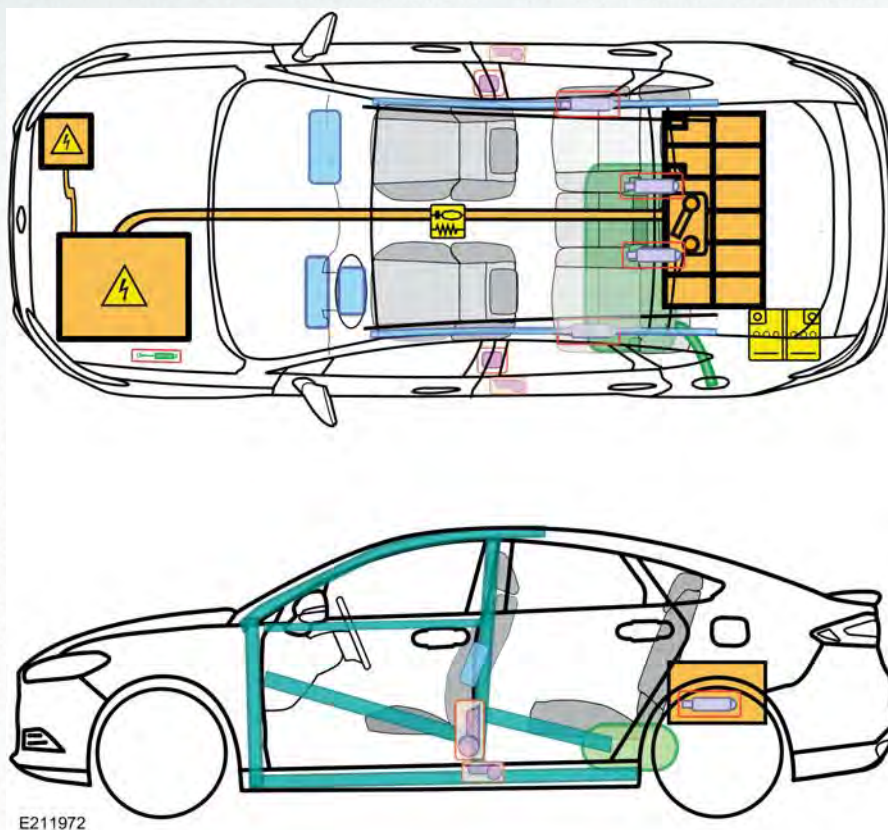

E211972

### Epígrafe

M

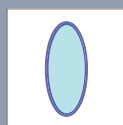

Airbag

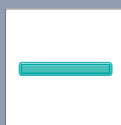

Refuerzos estructurales



Unidad de control

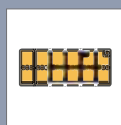

Batería de Alto Voltaje



Sistema de protección de los peatones



Generador de gas



Protección antivuelco activa

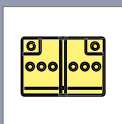

Batería

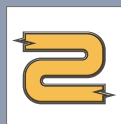

Cable de Alto Voltaje

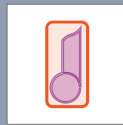

Tensor del cinturón de seguridad

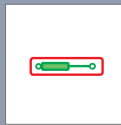

Dispositivo llenado de gas

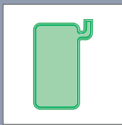

Depósito de combustible



Punto de desconexión del Alto Voltaje

(Fecha De Publicacion: : 02/2017)



## Desactivación del sistema de alta tensión

### Introducción

**¡TENGA EN CUENTA SIEMPRE QUE EL SISTEMA DE ALTA TENSIÓN DEL VEHÍCULO ESTÁ ENCENDIDO!  
ANTES DE ACCEDER AL VEHÍCULO, ASEGÚRESE DE QUE TODAS LAS ALIMENTACIONES ELÉCTRICAS  
EXTERNAS ESTÁN DESCONECTADAS (EJ.: CARGADOR ELÉCTRICO, HERRAMIENTAS ELÉCTRICAS).  
Si no se respetan estas advertencias, se pueden producir lesiones graves o incluso provocar la muerte.**

### IDENTIFICACIÓN DEL VEHÍCULO ELÉCTRICO

#### Identificación por el número de identificación del vehículo (VIN)

El décimo dígito del número de bastidor (VIN) identifica la línea híbrida del vehículo.

Casillas VIN 1, 2, 3, 4, 5, 6, 7, 8, 9 y 10	VEHÍCULO
WF0DXXWPC	Mondeo Hybrid
<b>VIN de muestra</b>	
WF0DXXWPCEB12345	

#### Identificación por las características del vehículo



1. Etiqueta HYBRID a ambos lados del vehículo, en las puertas delanteras, y en el portón trasero

## Identificación por las características del compartimento motor

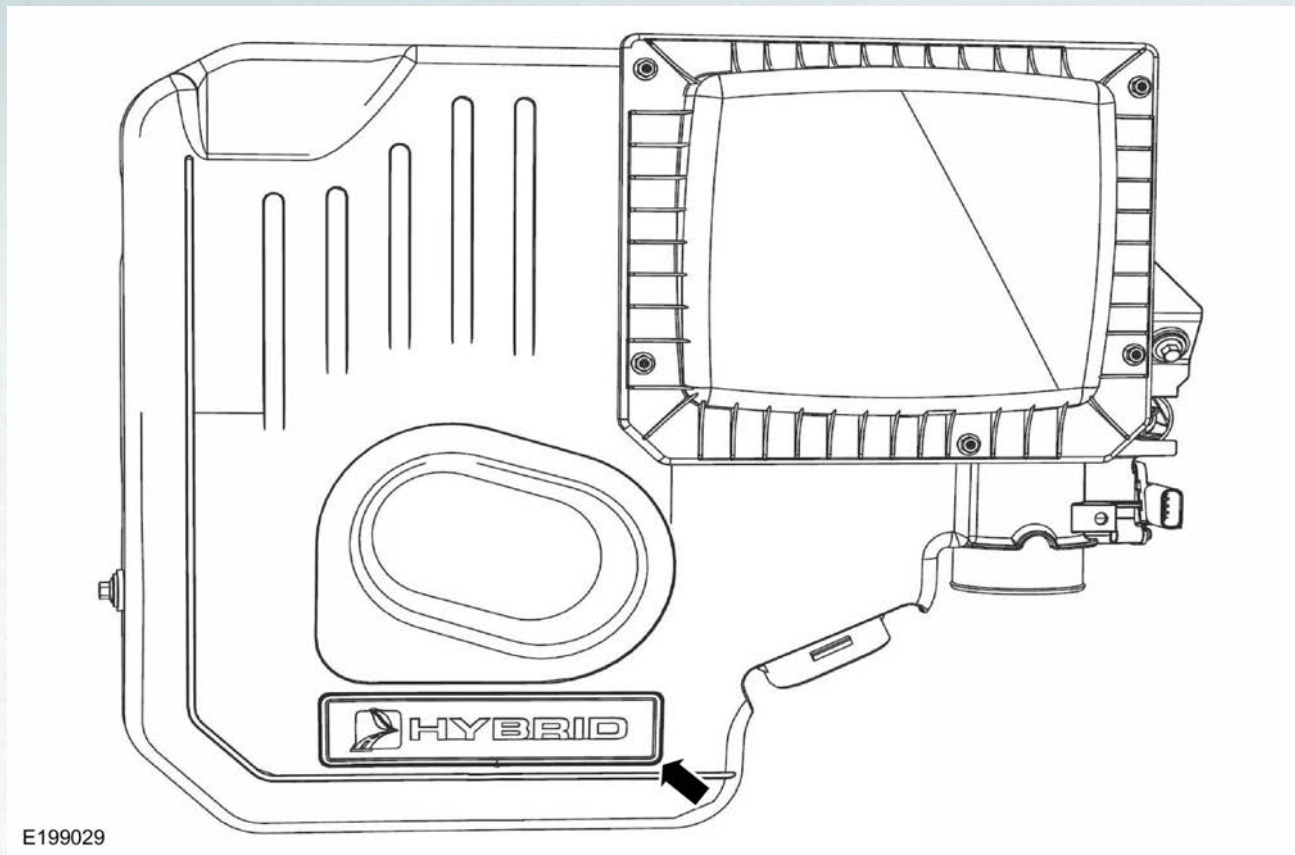

1. El vehículo Mondeo híbrido dispone de una cubierta de motor característica con el icono "HYBRID" en relieve.

## FUNCIONES DE DESCONEXIÓN ELÉCTRICA DE ALTA TENSIÓN

### AVISOS:

- ▲ Si desmonta la desconexión del servicio de alta tensión, se desconectará la alta tensión del vehículo. El paquete de la batería permanecerá activo y peligroso. No desconecte la carcasa de la batería de alta tensión. No manipule de ninguna manera el interior de las baterías o de la carcasa. Si es posible, aisle los componentes de alta tensión del vehículo y evite el contacto con ellos.
- ▲ Los daños en los vehículos eléctricos provocados por una colisión pueden poner en peligro los sistemas de seguridad de alta tensión y suponer un posible riesgo de descarga eléctrica de alta tensión. Extreme las precauciones y lleve siempre el equipamiento de seguridad del equipo de protección personal adecuado. Quítese todos los accesorios metálicos, incluidos reloj y anillos. Si no se respetan estas advertencias, se pueden producir lesiones graves o incluso provocar la muerte.

**Encendido desactivado** — Cuando el encendido está desactivado (y el vehículo no está cargando) la batería de alta tensión está desactivada.

**Desconexión del servicio de alta tensión** — Cuando las desconexiones de servicio de alta tensión se desmontan, el sistema de alta tensión queda desactivado.

### Desactivación

#### Método 1

**NOTA:** Es importante desactivar el encendido antes de desmontar la conexión de la batería de 12 V. Con el encendido activado, el sistema HV podría permanecer activo.

**Si no es posible acceder a la batería, pase al método 2.**

**1. Compruebe si el sistema de alta tensión está recibiendo alimentación.**

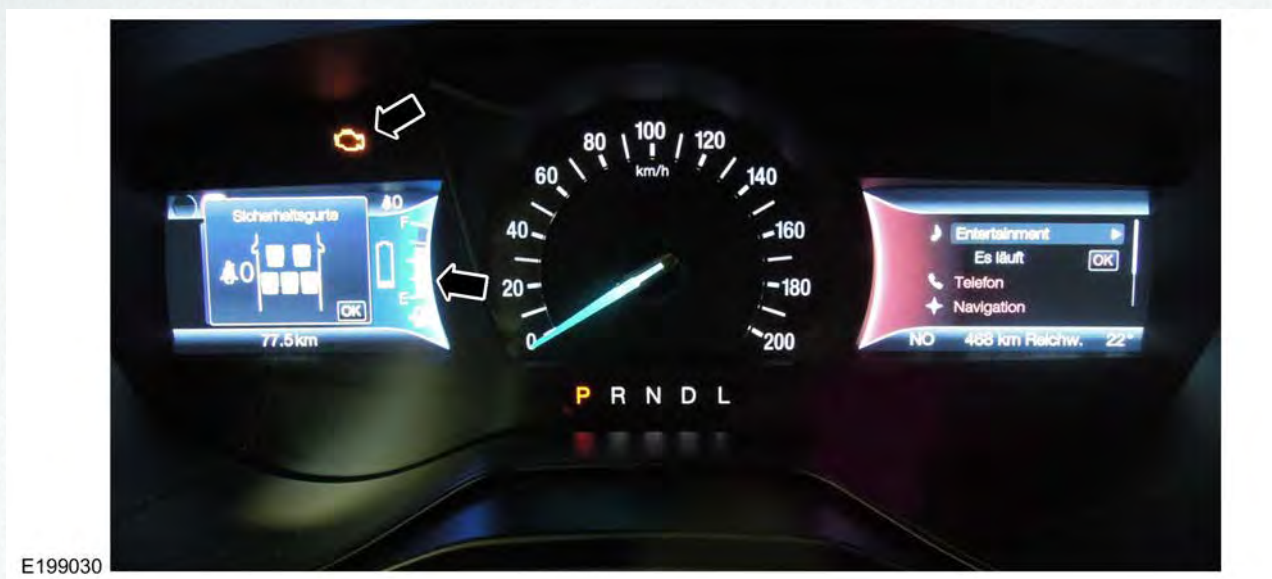

# FORD SERVICE

Tarjetas de rescate

**2. Si el sistema de alta tensión está activo, pulse una vez el botón de arranque/parada del motor.**



E199171



# FORD SERVICE

Tarjetas de rescate

## 3. Desmonte la cubierta para acceder a la batería de 12 V.

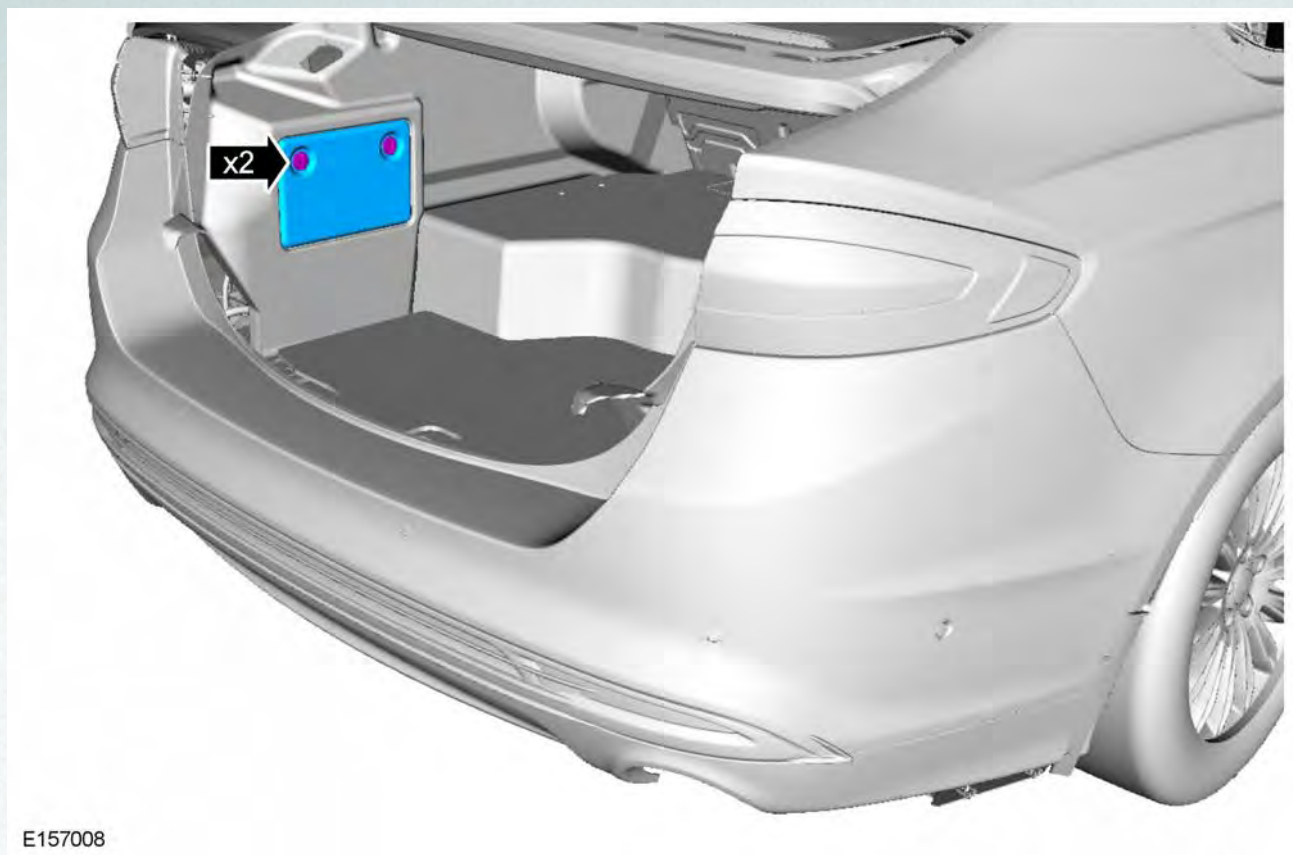

E157008

## 4. Desconecte el cable de la batería de 12 V.

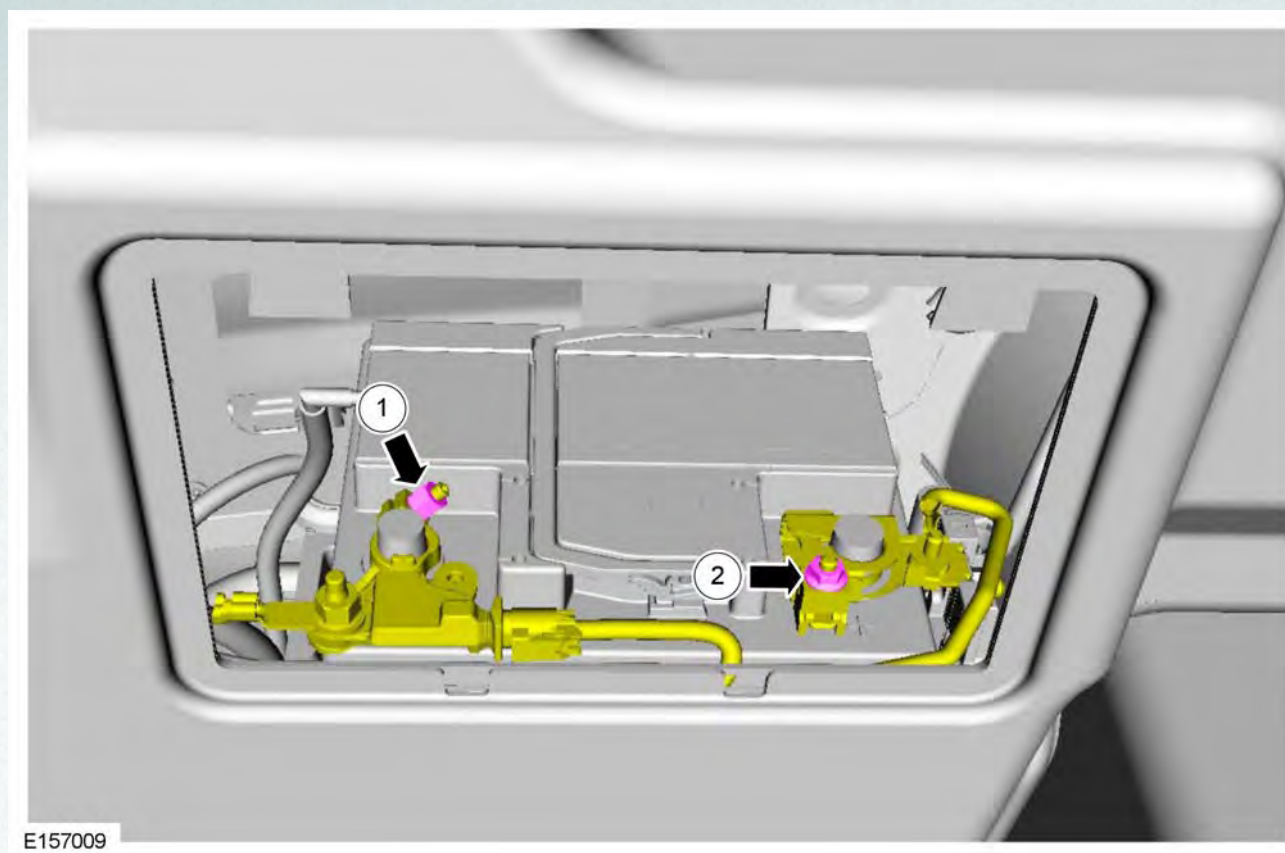

E157009

## Método 2

**NOTA:** Para acceder a la desconexión del servicio de alta tensión, debe bajar el respaldo del asiento trasero hasta el 60% de su recorrido.

# FORD SERVICE

Tarjetas de rescate

1. Localice la palanca de desbloqueo del respaldo del asiento, en la parte superior del respaldo.

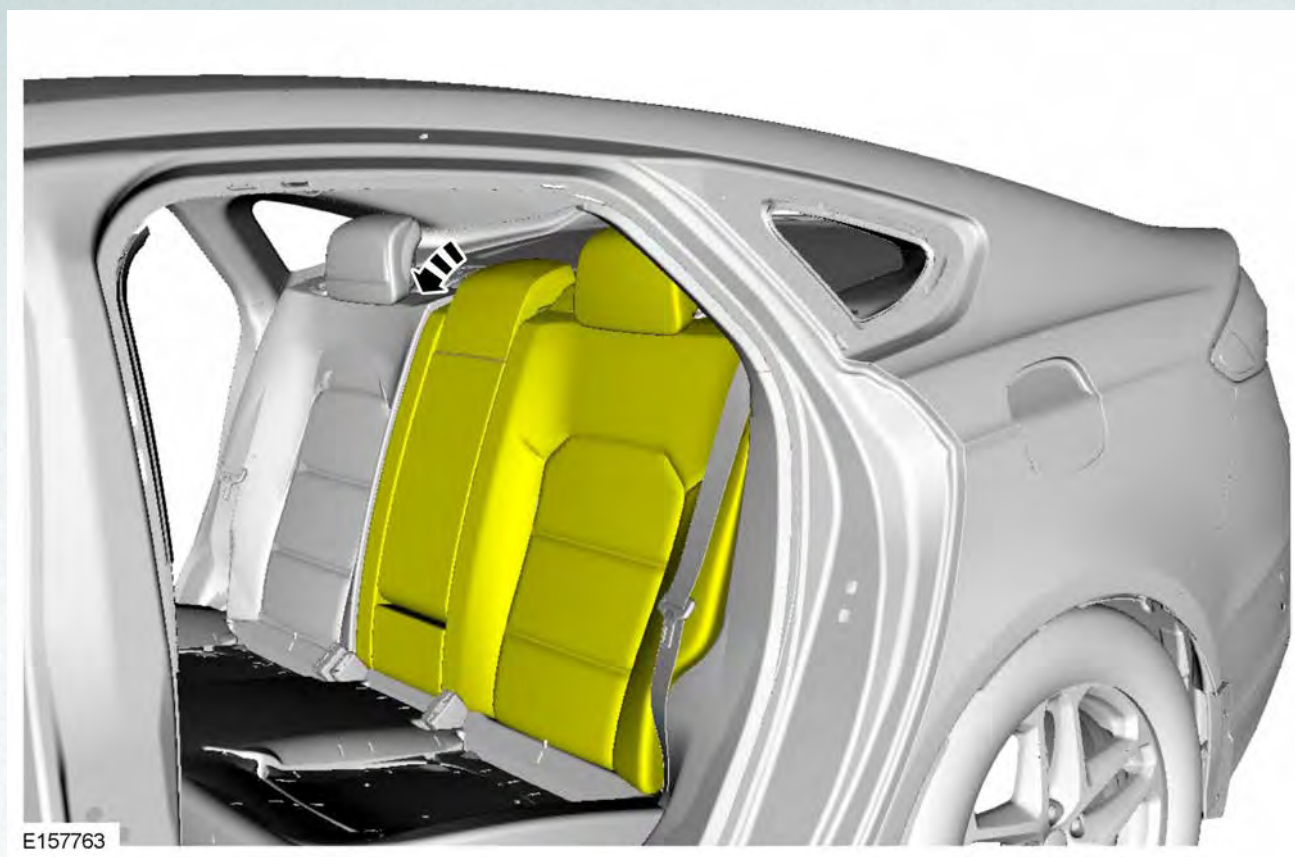

## 2. Retire la cubierta para acceder a la desconexión superior del servicio de la batería.

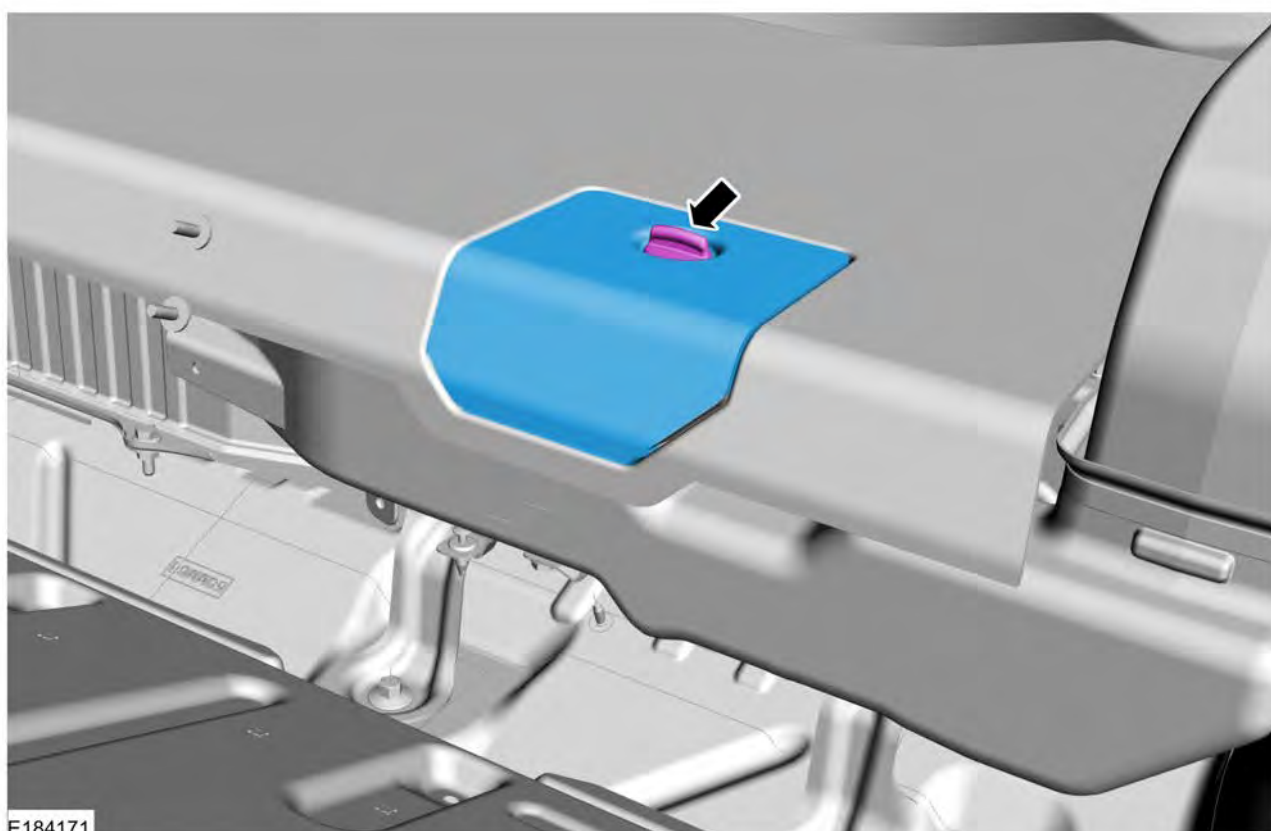

E184171

### 3. De estar instalados.

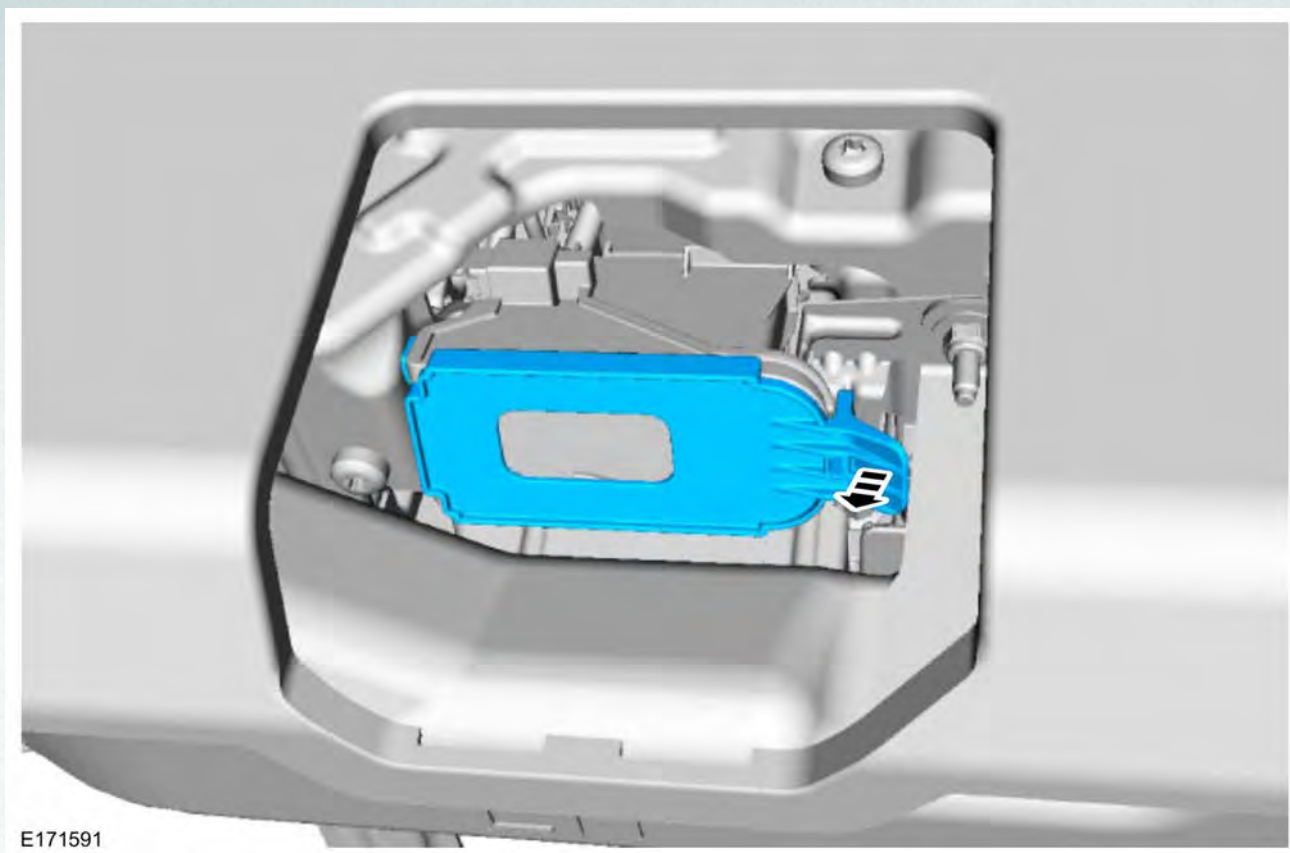

E171591

## 4. Desmonte la desconexión del servicio de alta tensión.

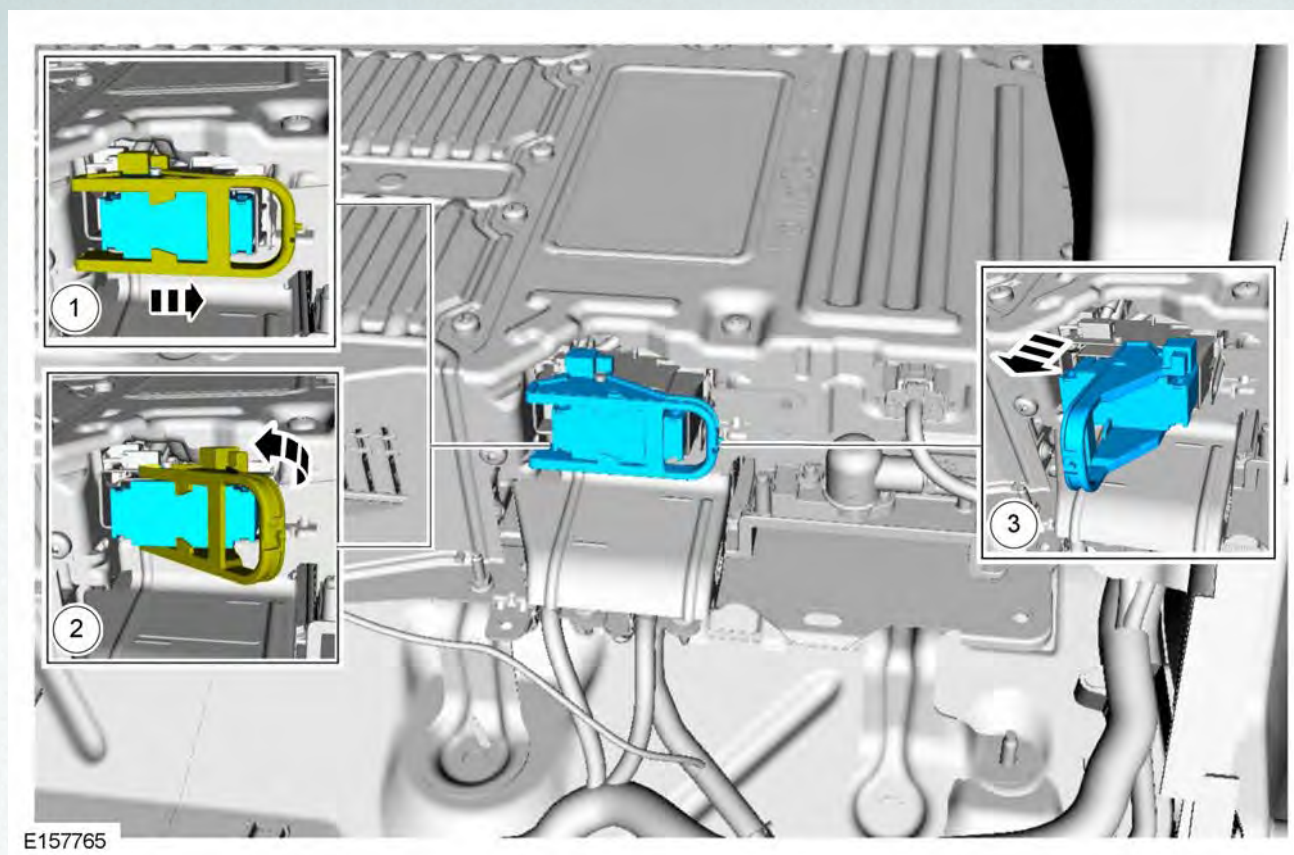

(Fecha De Publicacion: : 02/2017)

# FORD SERVICE

Tarjetas de rescate

## FORD Mondeo "Hybrid" - HEV

Familiar

01/2019 – >

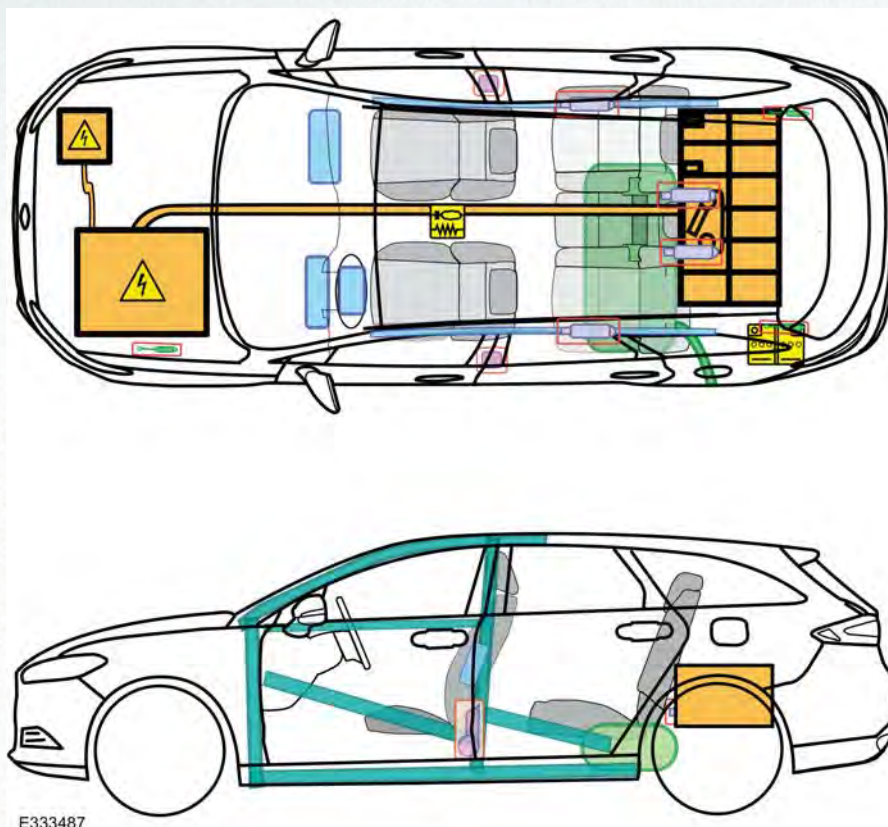
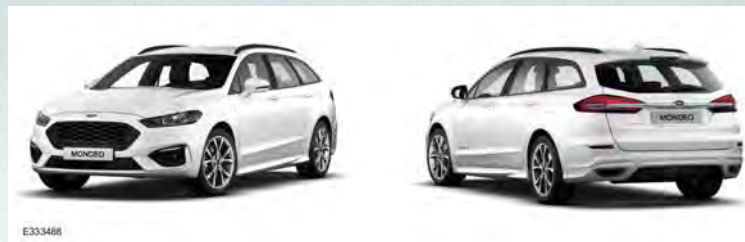

E333487

### Epígrafe

M

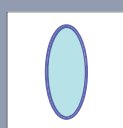

Airbag

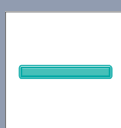

Refuerzos estructurales



Unidad de control

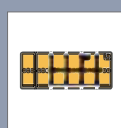

Batería de Alto Voltaje



Sistema de protección de los peatones



Generador de gas



Protección antivuelco activa

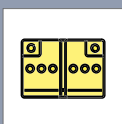

Batería

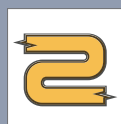

Cable de Alto Voltaje

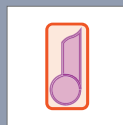

Tensor del cinturón de seguridad

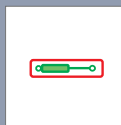

Dispositivo llenado de gas



Depósito de combustible



Punto de desconexión del Alto Voltaje

(Fecha De Publicacion: : 06/2020)



## Desactivación del sistema de alta tensión

### Introducción

**¡TENGA EN CUENTA SIEMPRE QUE EL SISTEMA DE ALTA TENSIÓN DEL VEHÍCULO ESTÁ ENCENDIDO!  
ANTES DE ACCEDER AL VEHÍCULO, ASEGÚRESE DE QUE TODAS LAS ALIMENTACIONES ELÉCTRICAS  
EXTERNAS ESTÁN DESCONECTADAS (EJ.: CARGADOR ELÉCTRICO, HERRAMIENTAS ELÉCTRICAS).  
Si no se respetan estas advertencias, se pueden producir lesiones graves o incluso provocar la muerte.**

### IDENTIFICACIÓN DEL VEHÍCULO ELÉCTRICO

#### Identificación por el número de identificación del vehículo (VIN)

El décimo dígito del número de bastidor (VIN) identifica la línea híbrida del vehículo.

Casillas VIN 1, 2, 3, 4, 5, 6, 7, 8, 9 y 10	VEHÍCULO
WF0DXXWPC	Mondeo Hybrid
<b>VIN de muestra</b>	
WF0DXXWPCEB12345	

#### Identificación por las características del vehículo



E333485

1. Etiqueta HYBRID en ambas puertas delanteras.



## Identificación por las características del compartimento motor

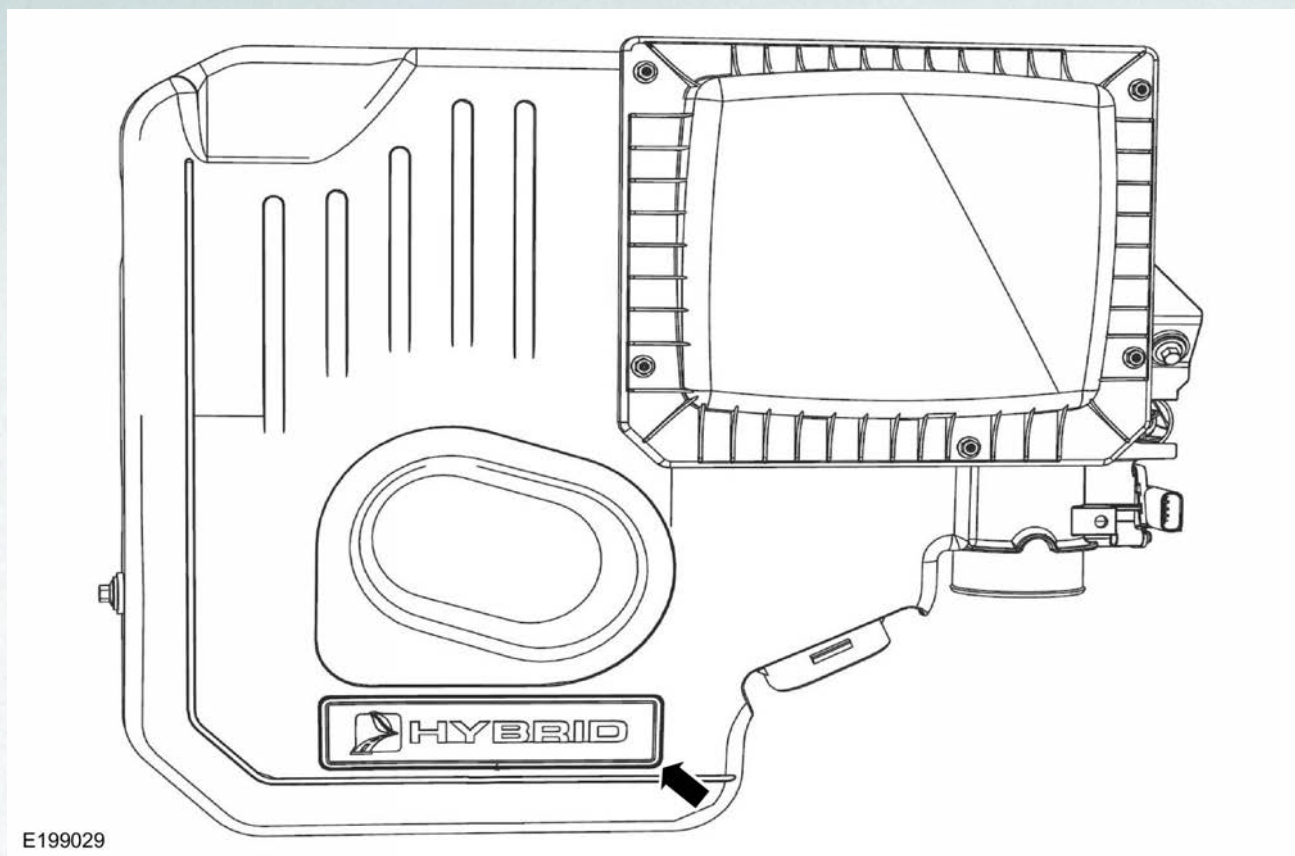

1. El vehículo Mondeo híbrido dispone de una cubierta de motor característica con el icono "HYBRID" en relieve.

## FUNCIONES DE DESCONEXIÓN ELÉCTRICA DE ALTA TENSIÓN

### AVISOS:

- ▲ Si desmonta la desconexión del servicio de alta tensión, se desconectará la alta tensión del vehículo. El paquete de la batería permanecerá activo y peligroso. No desconecte la carcasa de la batería de alta tensión. No manipule de ninguna manera el interior de las baterías o de la carcasa. Si es posible, aisle los componentes de alta tensión del vehículo y evite el contacto con ellos.
- ▲ Los daños en los vehículos eléctricos provocados por una colisión pueden poner en peligro los sistemas de seguridad de alta tensión y suponer un posible riesgo de descarga eléctrica de alta tensión. Extreme las precauciones y lleve siempre el equipamiento de seguridad del equipo de protección personal adecuado. Quítese todos los accesorios metálicos, incluidos reloj y anillos. Si no se respetan estas advertencias, se pueden producir lesiones graves o incluso provocar la muerte.

**Encendido desactivado** — Cuando el encendido está desactivado (y el vehículo no está cargando) la batería de alta tensión está desactivada.

**Desconexión del servicio de alta tensión** — Cuando las desconexiones de servicio de alta tensión se desmontan, el sistema de alta tensión queda desactivado.

### Desactivación

#### Método 1

**NOTA:** Es importante desactivar el encendido antes de desmontar la conexión de la batería de 12 V. Con el encendido activado, el sistema HV podría permanecer activo.

**Si no es posible acceder a la batería, pase al método 2.**

**1. Compruebe si el sistema de alta tensión está recibiendo alimentación.**



E199030

**2. Si el sistema de alta tensión está activo, pulse una vez el botón de arranque/parada del motor.**



E199171

**3. Desmonte la cubierta para acceder a la batería de 12 V.**

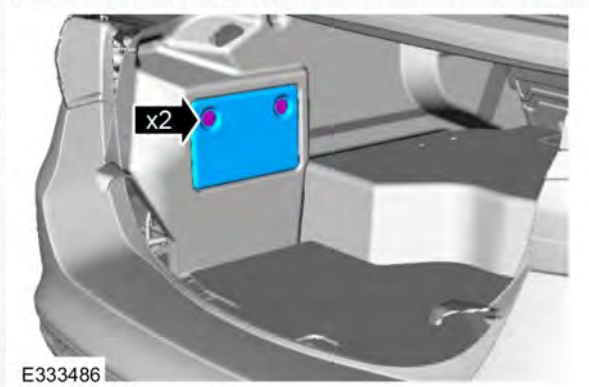

E333486

## 4. Desconecte el cable de la batería de 12 V.

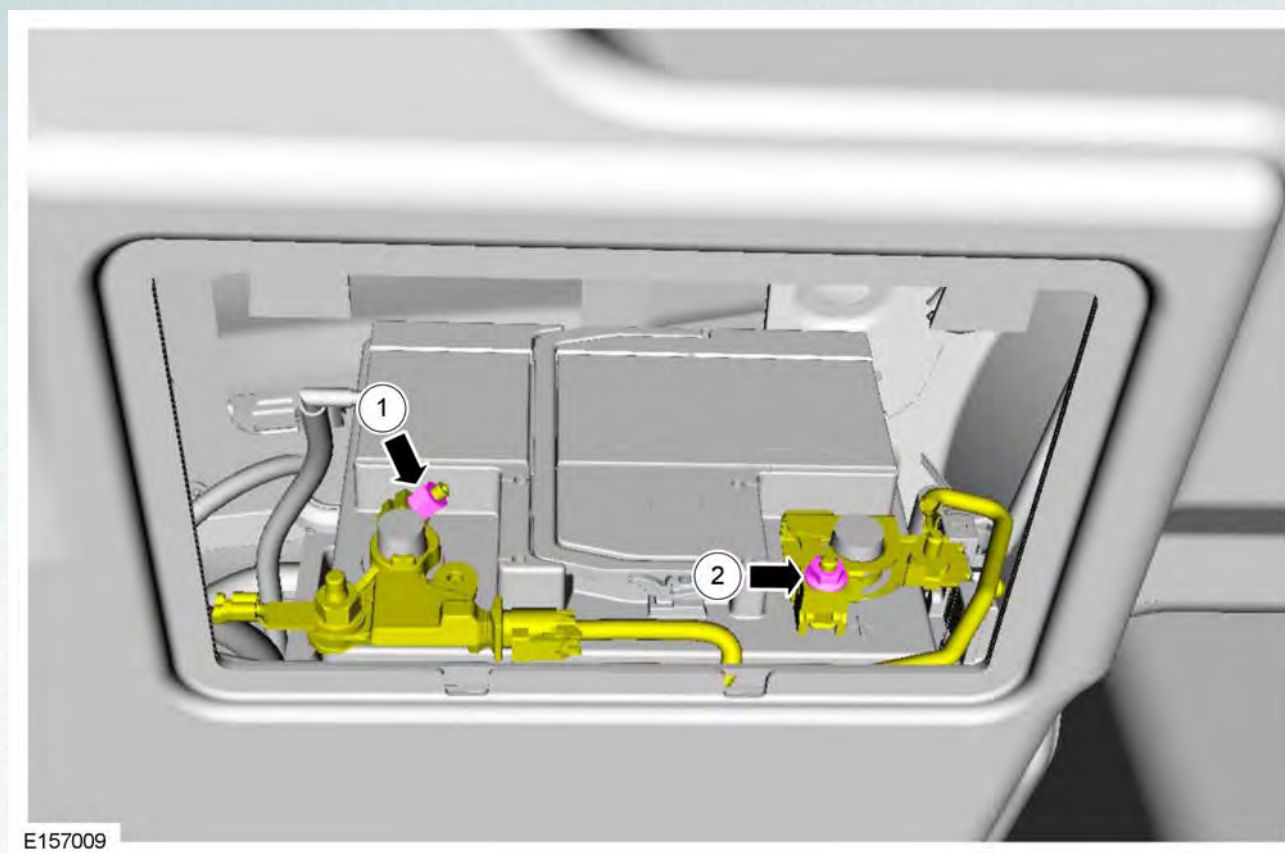

E157009

## Método 2

**NOTA:** Para acceder a la desconexión del servicio de alta tensión, debe bajar el respaldo del asiento trasero hasta el 60% de su recorrido.

# FORD SERVICE

Tarjetas de rescate

1. Localice la palanca de desbloqueo del respaldo del asiento, en la parte superior del respaldo.

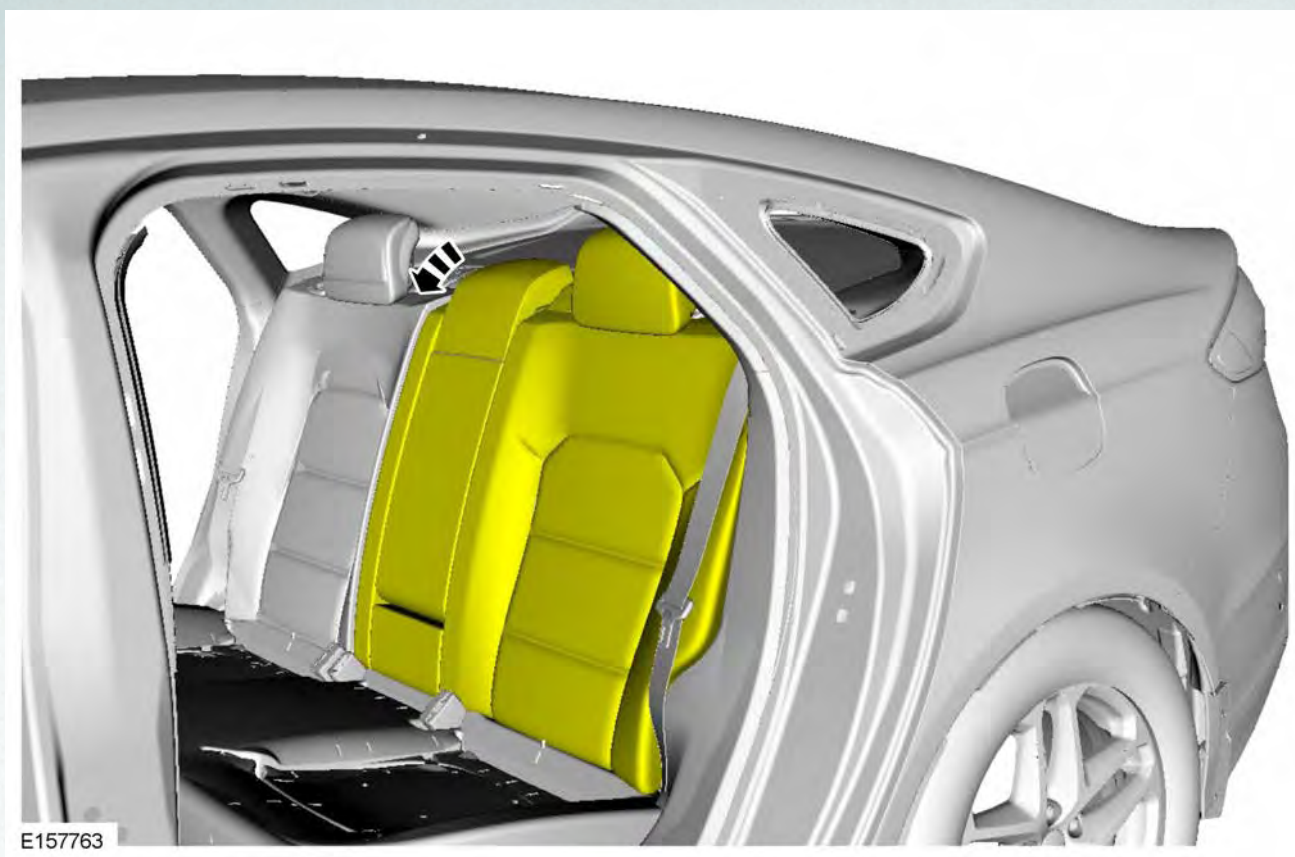

## 2. Retire la cubierta para acceder a la desconexión superior del servicio de la batería.

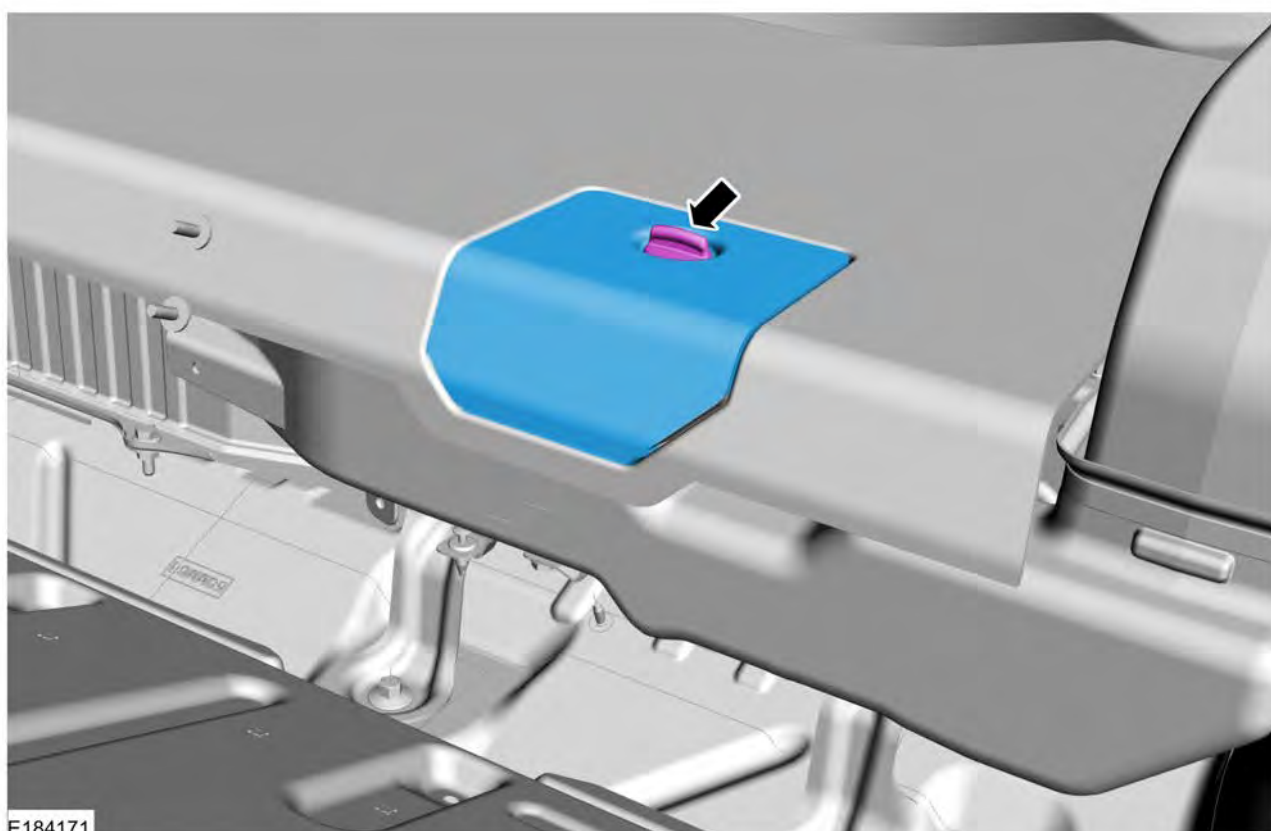

### 3. De estar instalados.

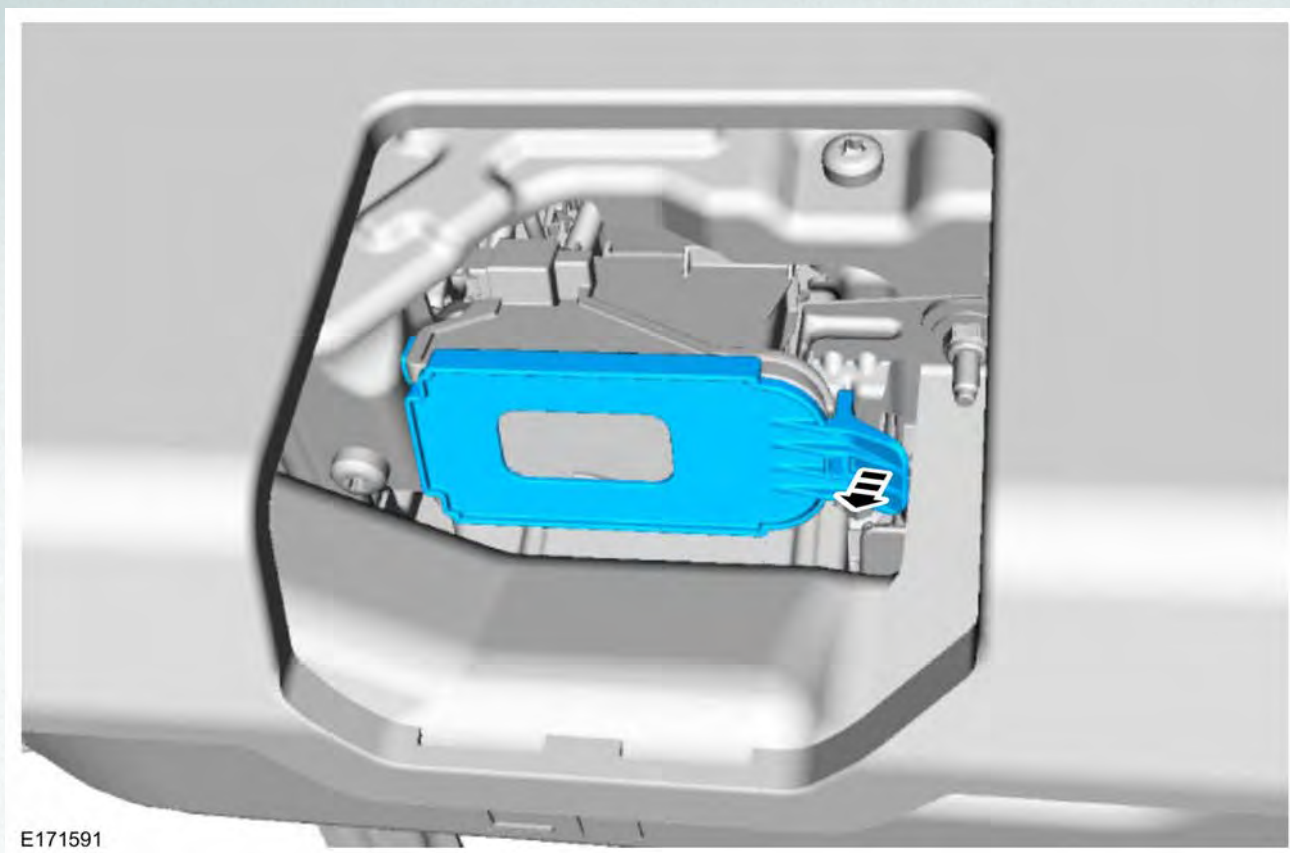

E171591

## 4. Desmonte la desconexión del servicio de alta tensión.

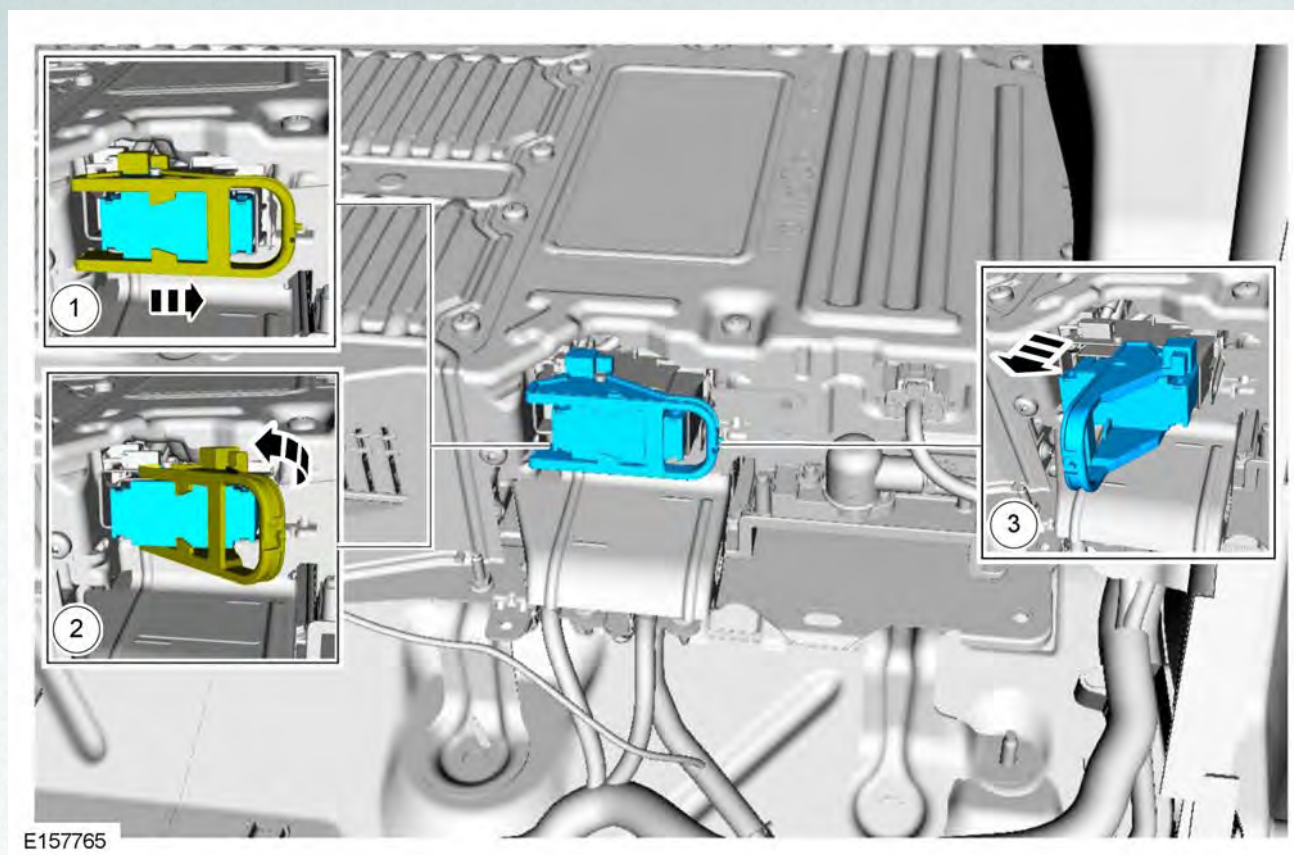

(Fecha De Publicacion: : 06/2020)



# FORD SERVICE

Tarjetas de rescate

## FORD Mustang

Coupé

03/2015 – >

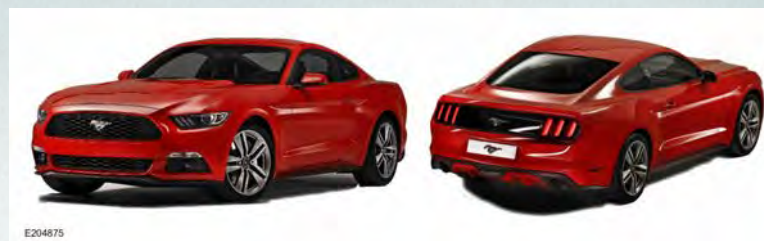

E204675

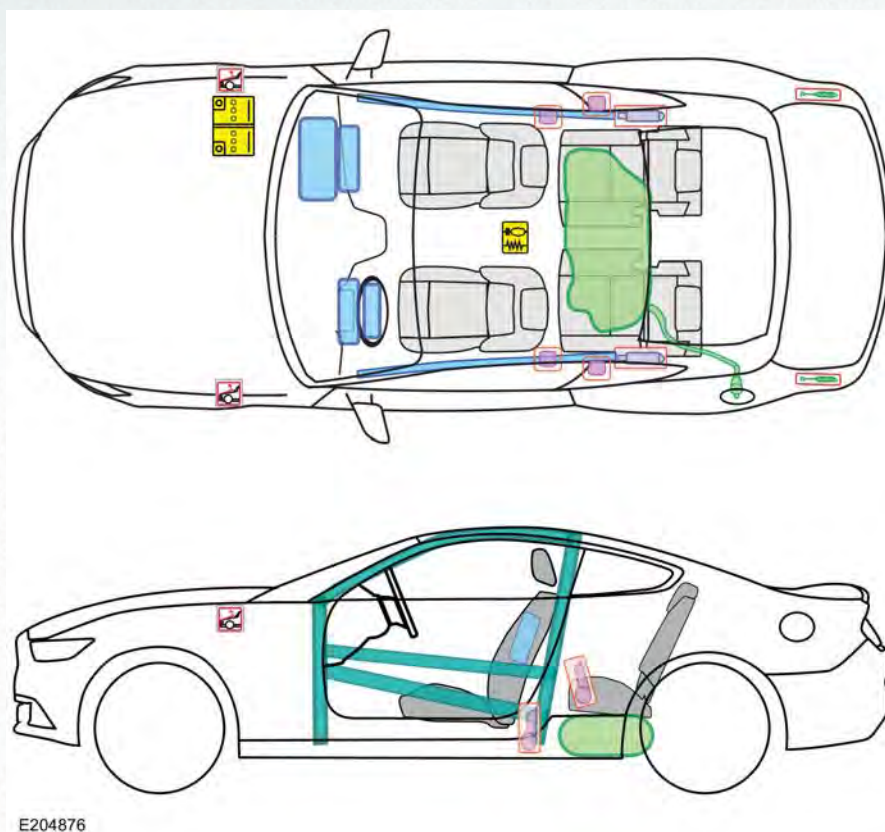

E204876

### Epígrafe

M

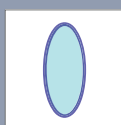

Airbag

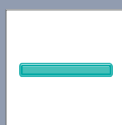

Refuerzos estructurales



Unidad de control



Sistema de protección de los peatones

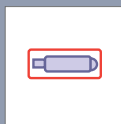

Generador de gas



Protección antivuelco activa

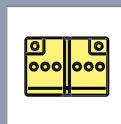

Batería

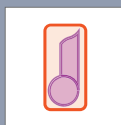

Tensor del cinturón de seguridad

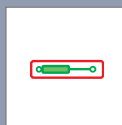

Dispositivo llenado de gas



Depósito de combustible

(Fecha De Publicacion: : 03/2017)



# FORD SERVICE

Tarjetas de rescate

## FORD Mustang

Descapotable

03/2015 – >

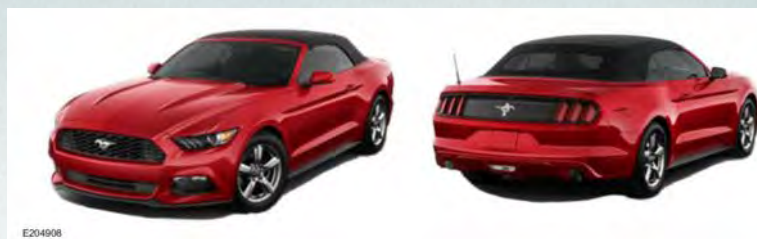

E204908

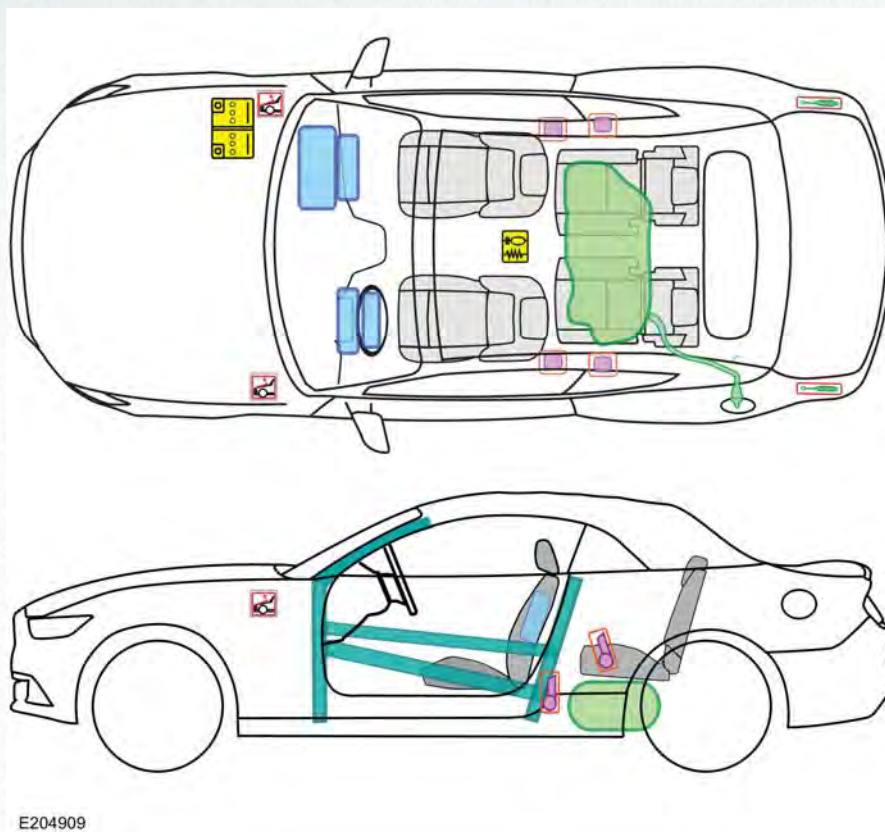

E204909

### Epígrafe

M

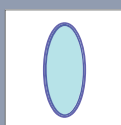

Airbag

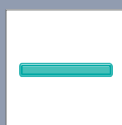

Refuerzos estructurales



Unidad de control



Sistema de protección de los peatones



Generador de gas



Protección antivuelco activa

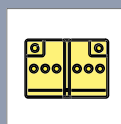

Batería

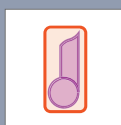

Tensor del cinturón de seguridad

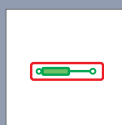

Dispositivo llenado de gas



Depósito de combustible

(Fecha De Publicacion: : 03/2017)



# FORD SERVICE

Tarjetas de rescate

## FORD Puma

10/2019 – >

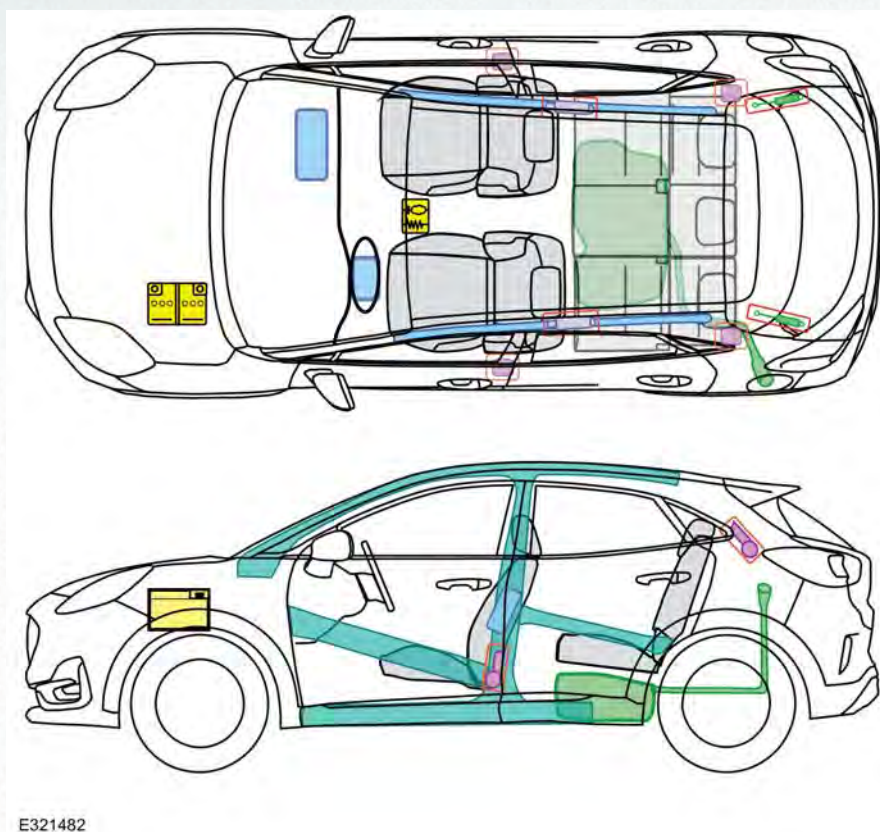

### Epígrafe

P

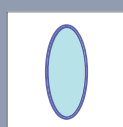

Airbag

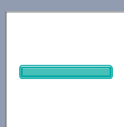

Refuerzos estructurales



Unidad de control



Sistema de protección de los peatones



Generador de gas

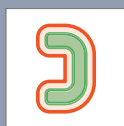

Protección antivuelco activa

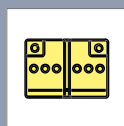

Batería

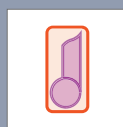

Tensor del cinturón de seguridad



Dispositivo llenado de gas



Depósito de combustible

(Fecha De Publicacion: : 11/2019)



# FORD SERVICE

Tarjetas de rescate

## FORD Puma mHEV

1,0l EcoBoost (92kW/125CV) (B7), 1,0l EcoBoost (114kW/155CV) (BZ)

10/2019 – 04/2020

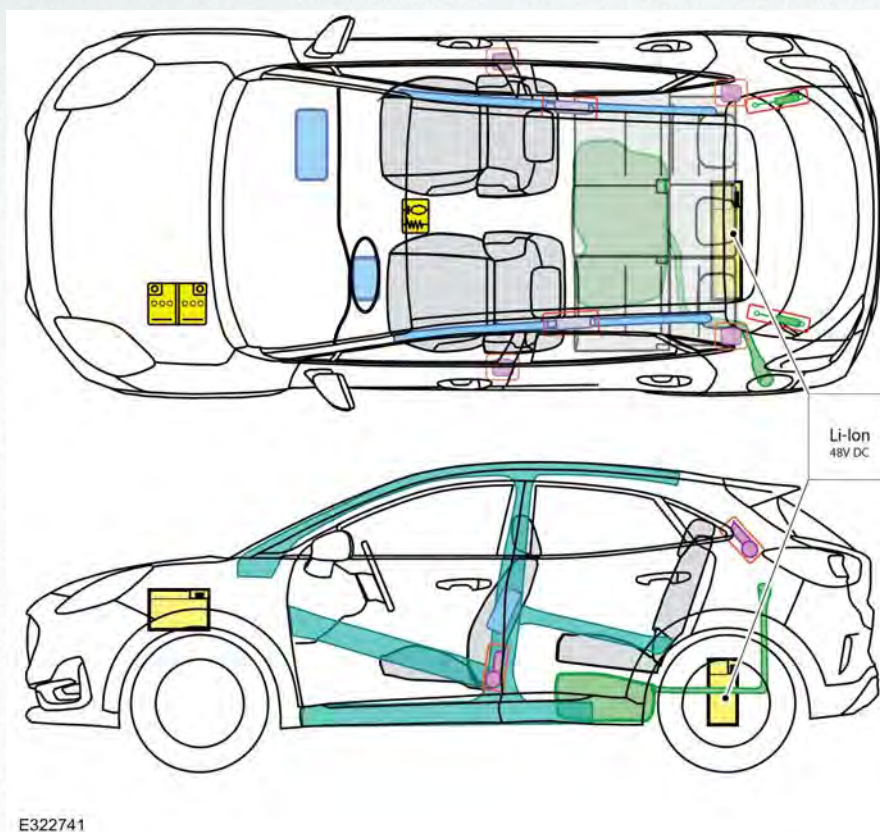

### Epígrafe

P

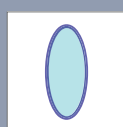

Airbag

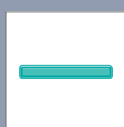

Refuerzos estructurales



Unidad de control



Sistema de protección de los peatones



Generador de gas

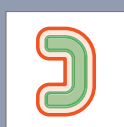

Protección antivuelco activa

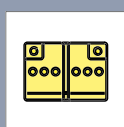

Batería

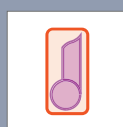

Tensor del cinturón de seguridad

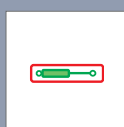

Dispositivo llenado de gas



Depósito de combustible

(Fecha De Publicacion: : 11/2019)



# FORD SERVICE

Tarjetas de rescate

## FORD Puma mHEV

1,0l EcoBoost (92kW/125CV) (B7), 1,0l EcoBoost (114kW/155CV) (BZ)

04/2020 – >

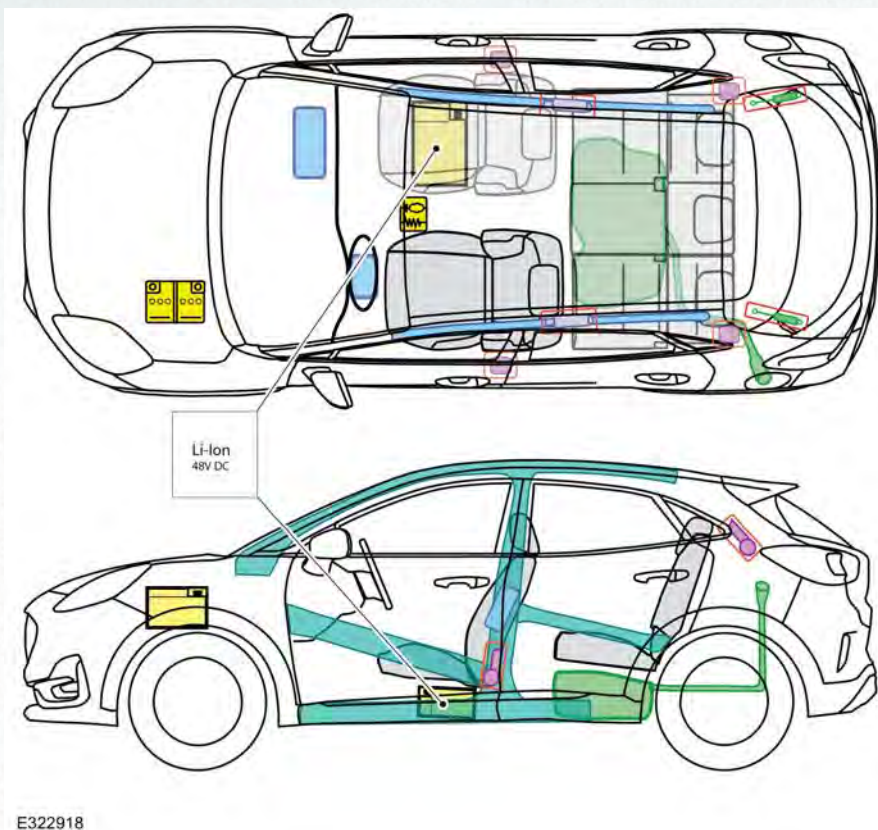

E322918

Epígrafe				P			
	Airbag		Refuerzos estructurales		Unidad de control		Sistema de protección de los peatones
	Generador de gas		Protección antivuelco activa		Batería		
	Tensor del cinturón de seguridad		Dispositivo llenado de gas		Depósito de combustible		

(Fecha De Publicacion: : 05/2021)



# FORD SERVICE

Tarjetas de rescate

## FORD Ranger

06/2006 – 07/2011

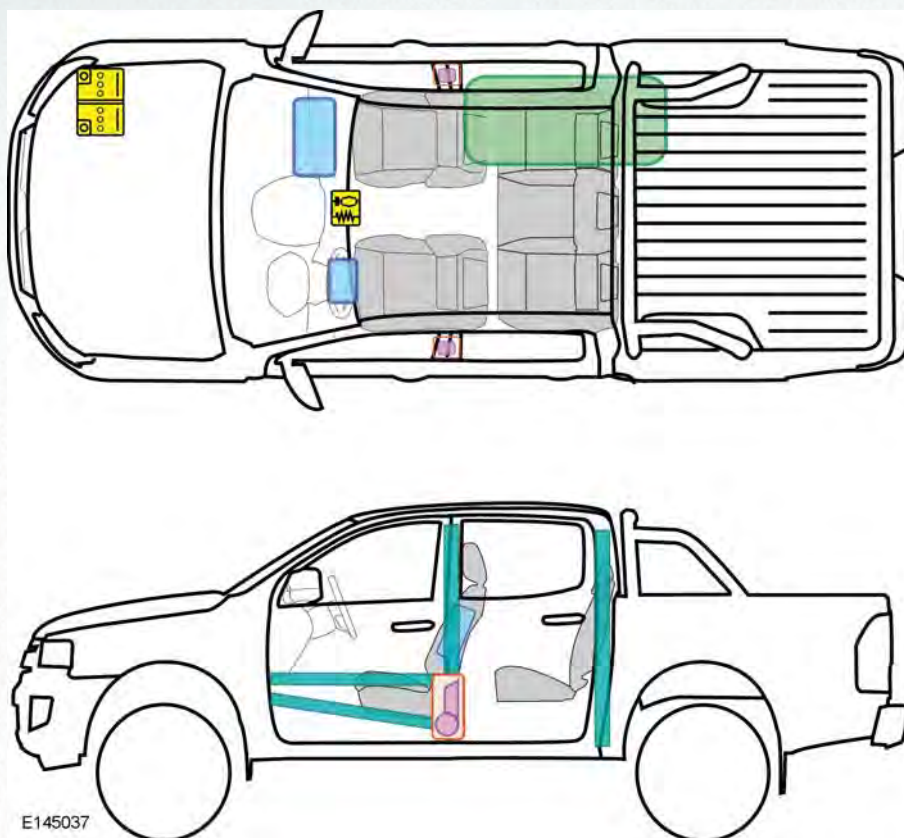

### Epígrafe

**R**

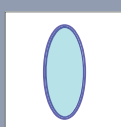

Airbag



Refuerzos estructurales



Unidad de control



Sistema de protección de los peatones



Generador de gas



Protección antivuelco activa

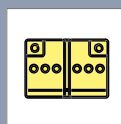

Batería

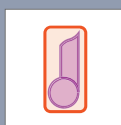

Tensor del cinturón de seguridad

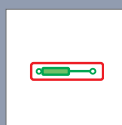

Dispositivo llenado de gas



Depósito de combustible

(Fecha De Publicacion: : 01/2012)



# FORD SERVICE

Tarjetas de rescate

## FORD Ranger

07/2011 – >

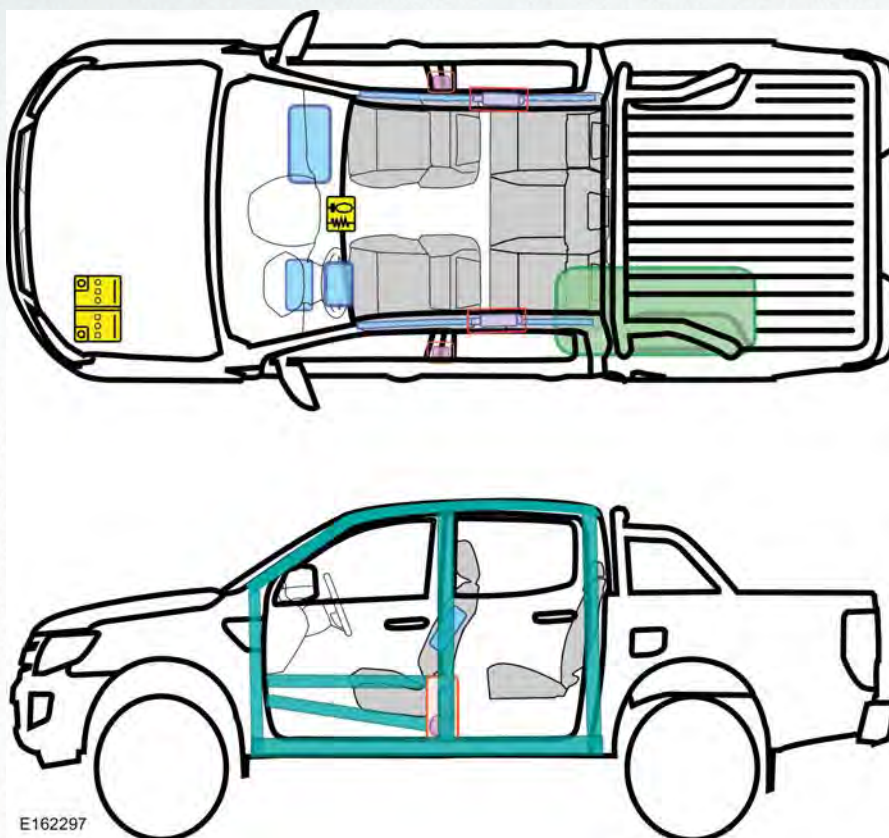

E162297

### Epígrafe

**R**

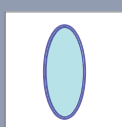

Airbag

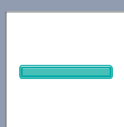

Refuerzos estructurales



Unidad de control



Sistema de protección de los peatones



Generador de gas



Protección antivuelco activa

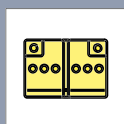

Batería

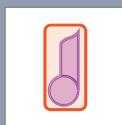

Tensor del cinturón de seguridad

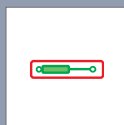

Dispositivo llenado de gas



Depósito de combustible

(Fecha De Publicacion: : 01/2016)



# FORD SERVICE

Tarjetas de rescate

## FORD S-MAX

02/2006 – 05/2015

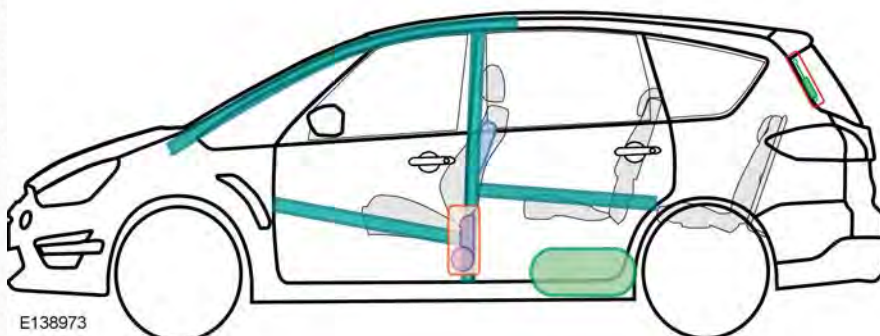
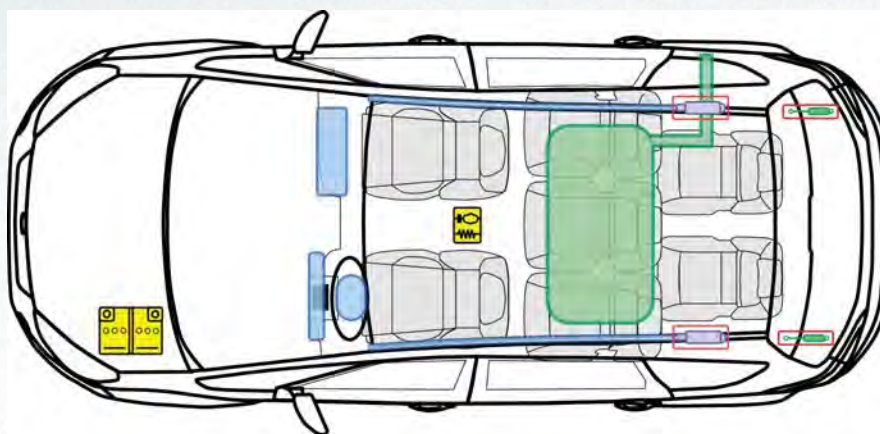

E138973

### Epígrafe

**S**

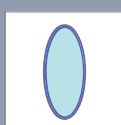

Airbag

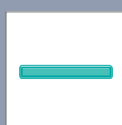

Refuerzos estructurales



Unidad de control



Sistema de protección de los peatones



Generador de gas



Protección antivuelco activa

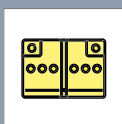

Batería

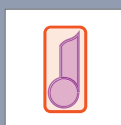

Tensor del cinturón de seguridad

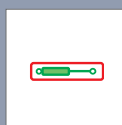

Dispositivo llenado de gas



Depósito de combustible

(Fecha De Publicacion: : 06/2015)





# FORD SERVICE

Tarjetas de rescate

## FORD S-MAX

5 puertas SAV

05/2015 – >

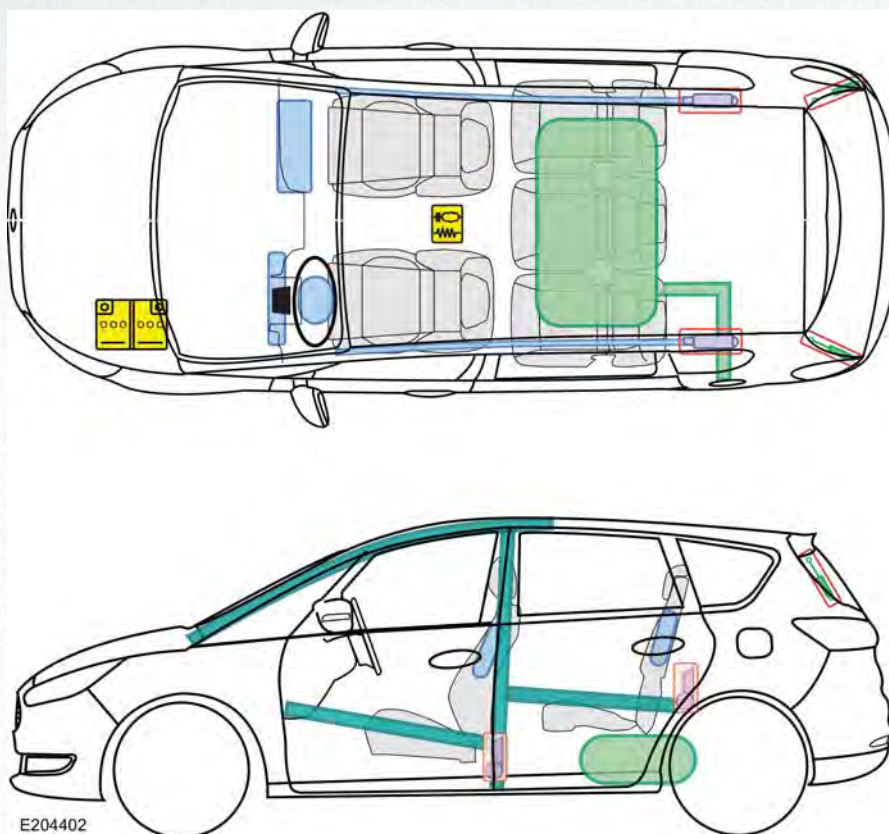

E204402

### Epígrafe

S

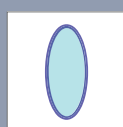

Airbag

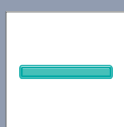

Refuerzos estructurales



Unidad de control



Sistema de protección de los peatones



Generador de gas

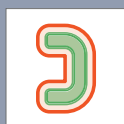

Protección antivuelco activa

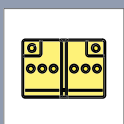

Batería

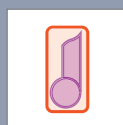

Tensor del cinturón de seguridad

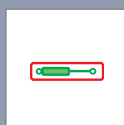

Dispositivo llenado de gas



Depósito de combustible

(Fecha De Publicacion: : 06/2015)



# FORD SERVICE

Tarjetas de rescate

## FORD Streetka





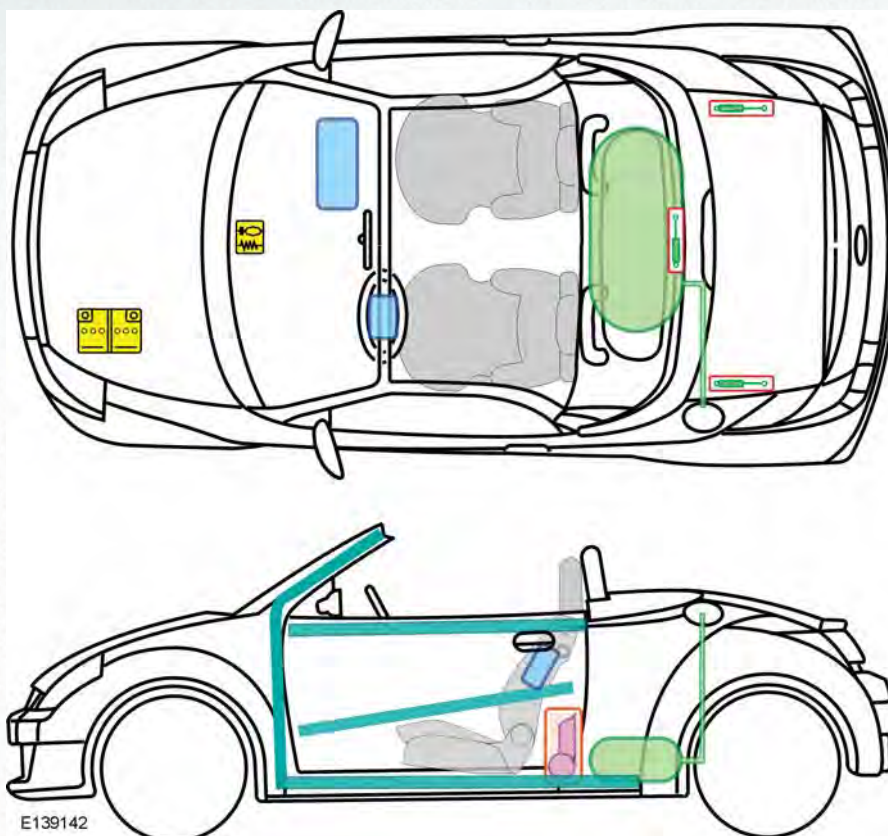



Descapotable

01/2003 – 07/2005

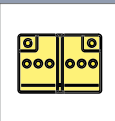
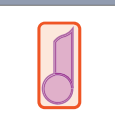

### Epígrafe

S

	Airbag		Refuerzos estructurales		Unidad de control		Sistema de protección de los peatones
	Generador de gas		Protección antivuelco activa		Batería		
	Tensor del cinturón de seguridad		Dispositivo llenado de gas		Depósito de combustible		

(Fecha De Publicacion: : 03/2011)



# FORD SERVICE

Tarjetas de rescate

## FORD **Tourneo Connect**

09/2013 – >

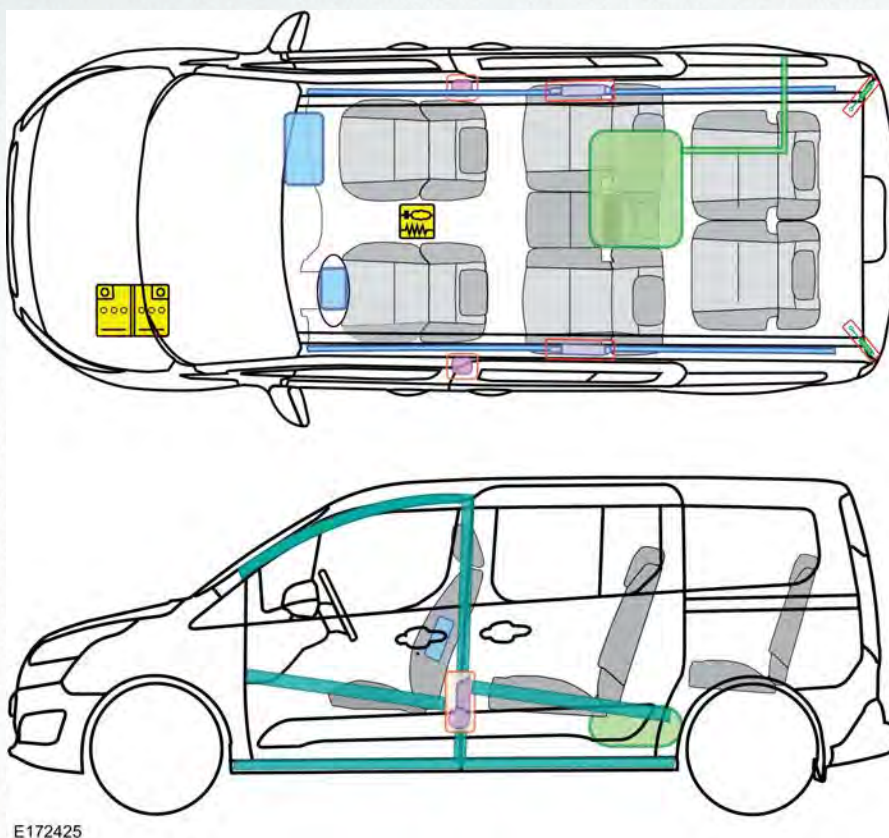

E172425

### Epígrafe

T

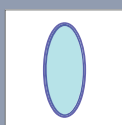

Airbag



Refuerzos estructurales



Unidad de control



Sistema de protección de los peatones

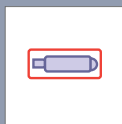

Generador de gas



Protección antivuelco activa

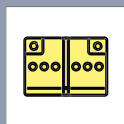

Batería

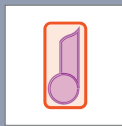

Tensor del cinturón de seguridad

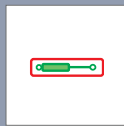

Dispositivo llenado de gas



Depósito de combustible

(Fecha De Publicacion: : 09/2013)



# FORD SERVICE

Tarjetas de rescate

## FORD **Tourneo Connect**

06/2002 – 07/2013

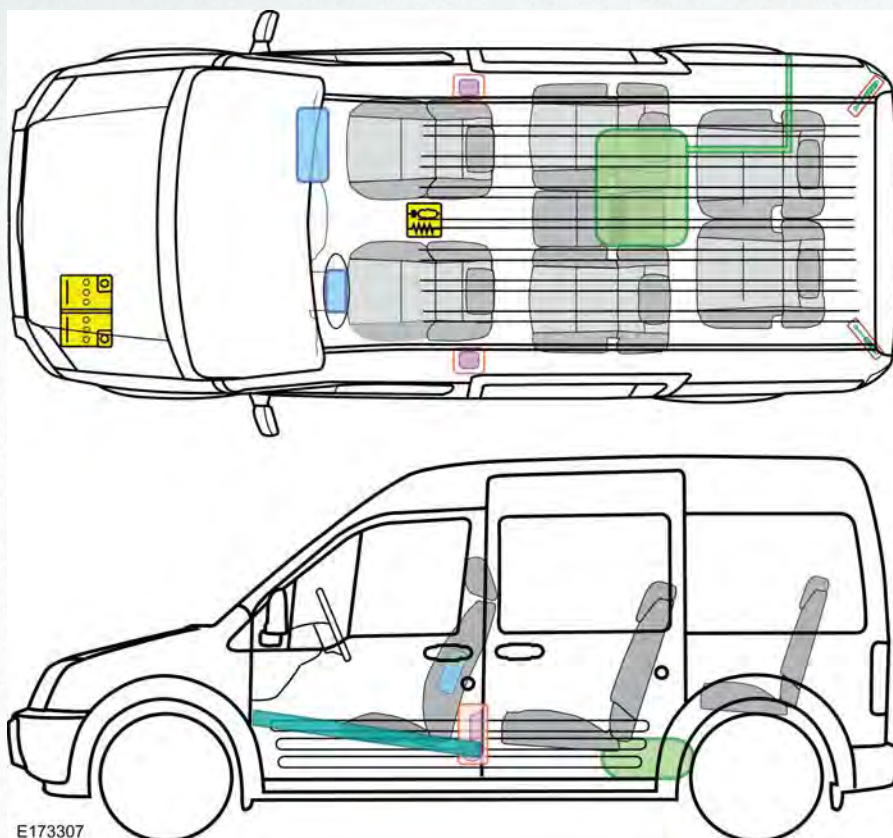

### Epígrafe

T

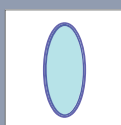

Airbag

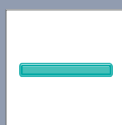

Refuerzos estructurales



Unidad de control



Sistema de protección de los peatones



Generador de gas



Protección antivuelco activa

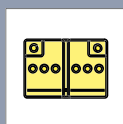

Batería

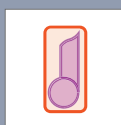

Tensor del cinturón de seguridad

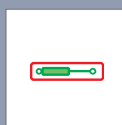

Dispositivo llenado de gas



Depósito de combustible

(Fecha De Publicacion: : 09/2013)



# FORD SERVICE

Tarjetas de rescate

## FORD **Tourneo Courier**

03/2014 – >

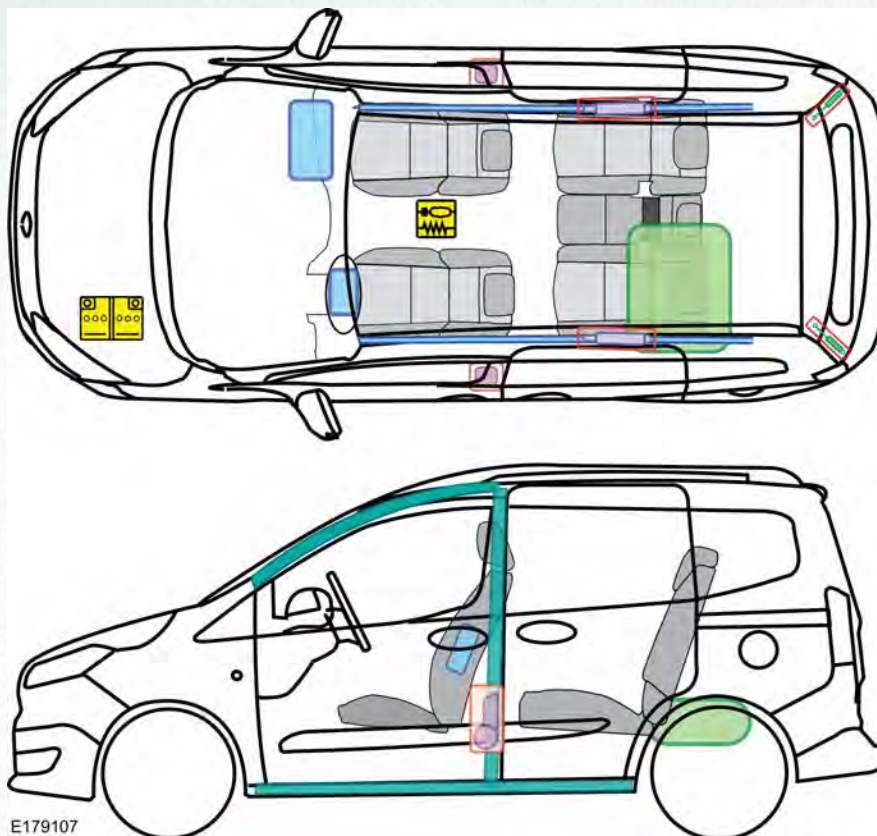

E179107

### Epígrafe

T

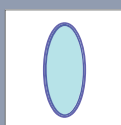

Airbag

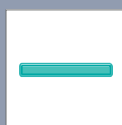

Refuerzos estructurales



Unidad de control



Sistema de protección de los peatones

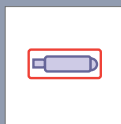

Generador de gas



Protección antivuelco activa

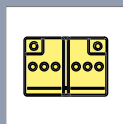

Batería

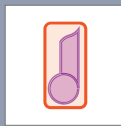

Tensor del cinturón de seguridad

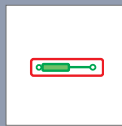

Dispositivo llenado de gas

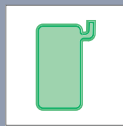

Depósito de combustible

(Fecha De Publicacion: : 01/2014)



# FORD SERVICE

Tarjetas de rescate

## FORD **Tourneo Custom**

07/2012 – >

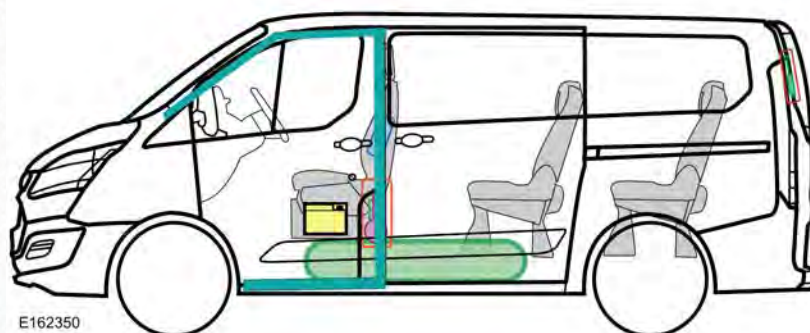
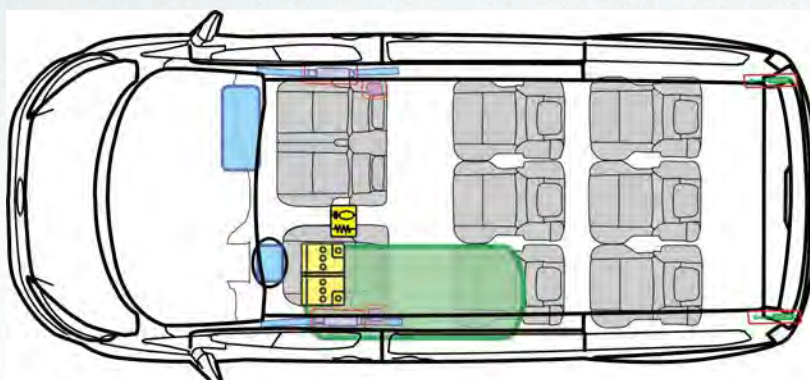

### Epígrafe

T

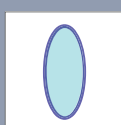

Airbag

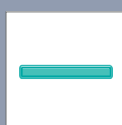

Refuerzos estructurales



Unidad de control



Sistema de protección de los peatones



Generador de gas



Protección antivuelco activa

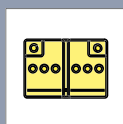

Batería

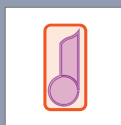

Tensor del cinturón de seguridad

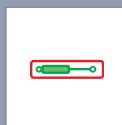

Dispositivo llenado de gas

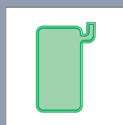

Depósito de combustible

(Fecha De Publicacion: : 02/2014)



### FORD **Tourneo Custom mHEV**

04/2019 – >

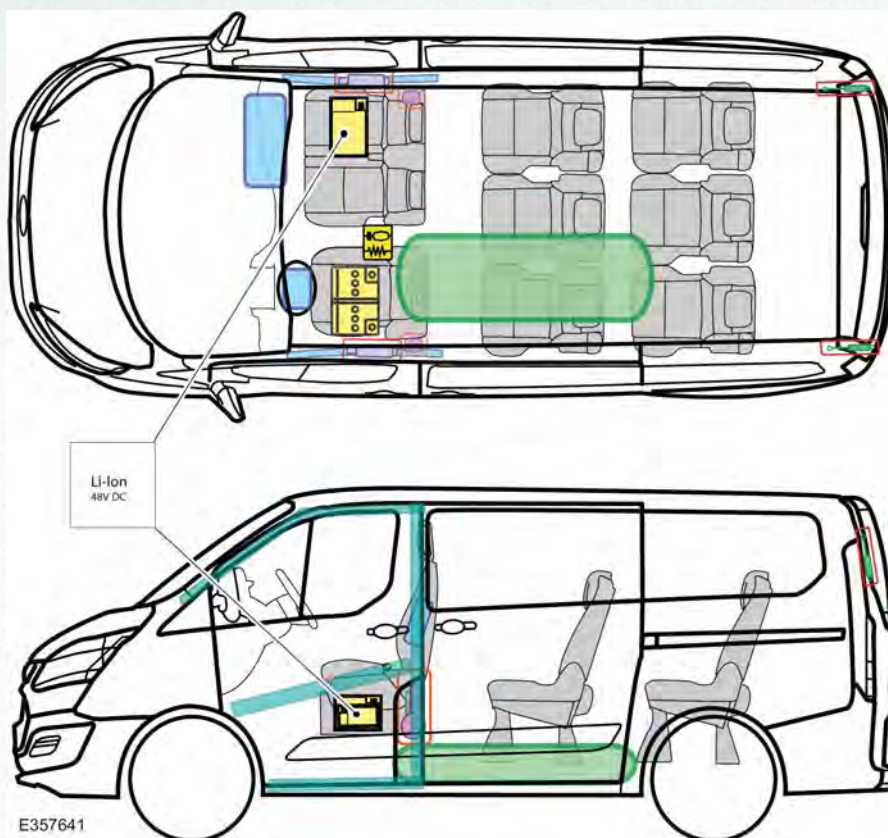

#### Epígrafe

T

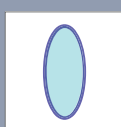

Airbag

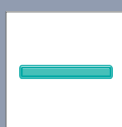

Refuerzos estructurales



Unidad de control



Sistema de protección de los peatones



Generador de gas



Protección antivuelco activa

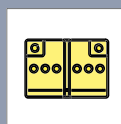

Batería

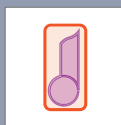

Tensor del cinturón de seguridad

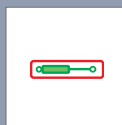

Dispositivo llenado de gas



Depósito de combustible

(Fecha De Publicacion: : 04/2021)

# FORD SERVICE

Tarjetas de rescate

## FORD Transit 2014.5

Autobús M2

08/2013 – >

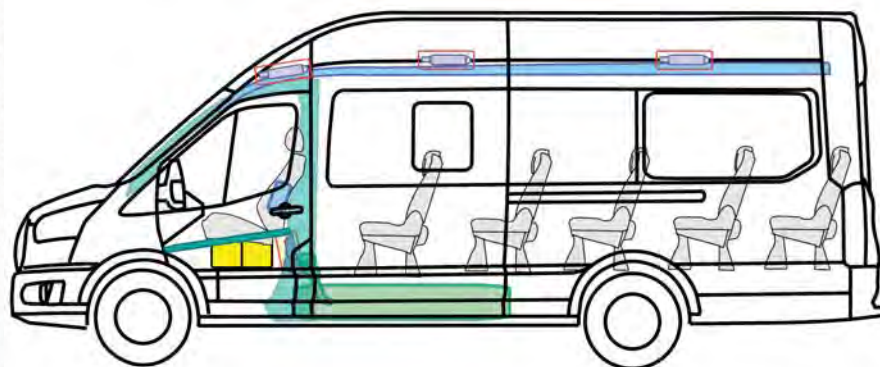
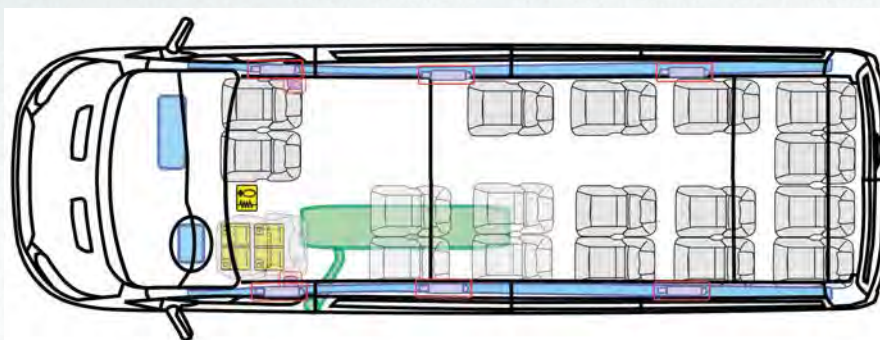

E291598

### Epígrafe

T

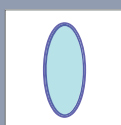

Airbag

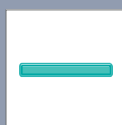

Refuerzos estructurales



Unidad de control



Sistema de protección de los peatones



Generador de gas



Protección antivuelco activa

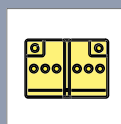

Batería

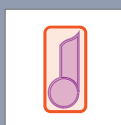

Tensor del cinturón de seguridad

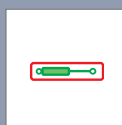

Dispositivo llenado de gas



Depósito de combustible

(Fecha De Publicacion: : 01/2019)





# FORD SERVICE

Tarjetas de rescate

## FORD Transit 2014.5

Chasis cabina

08/2013 – >

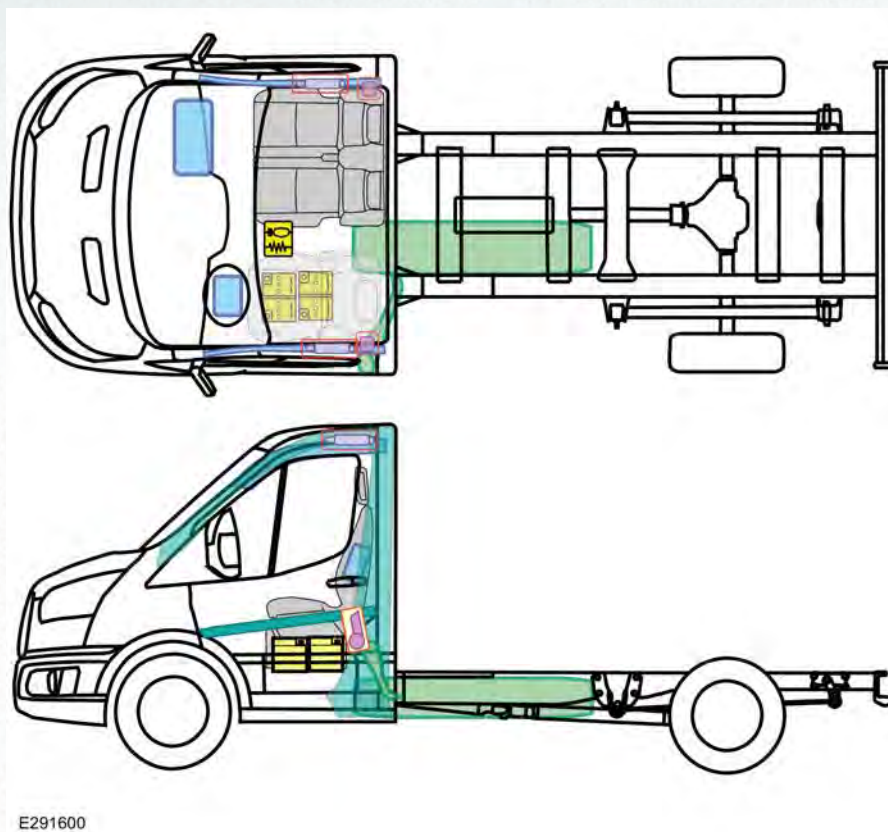

E291600

### Epígrafe

T

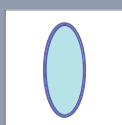

Airbag

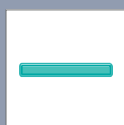

Refuerzos estructurales



Unidad de control



Sistema de protección de los peatones

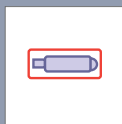

Generador de gas



Protección antivuelco activa

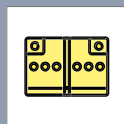

Batería

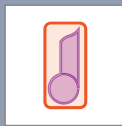

Tensor del cinturón de seguridad

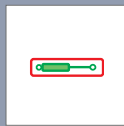

Dispositivo llenado de gas



Depósito de combustible

(Fecha De Publicacion: : 01/2019)



# FORD SERVICE

Tarjetas de rescate

## FORD Transit 2014.5

Chasis cabina doble

08/2013 – >

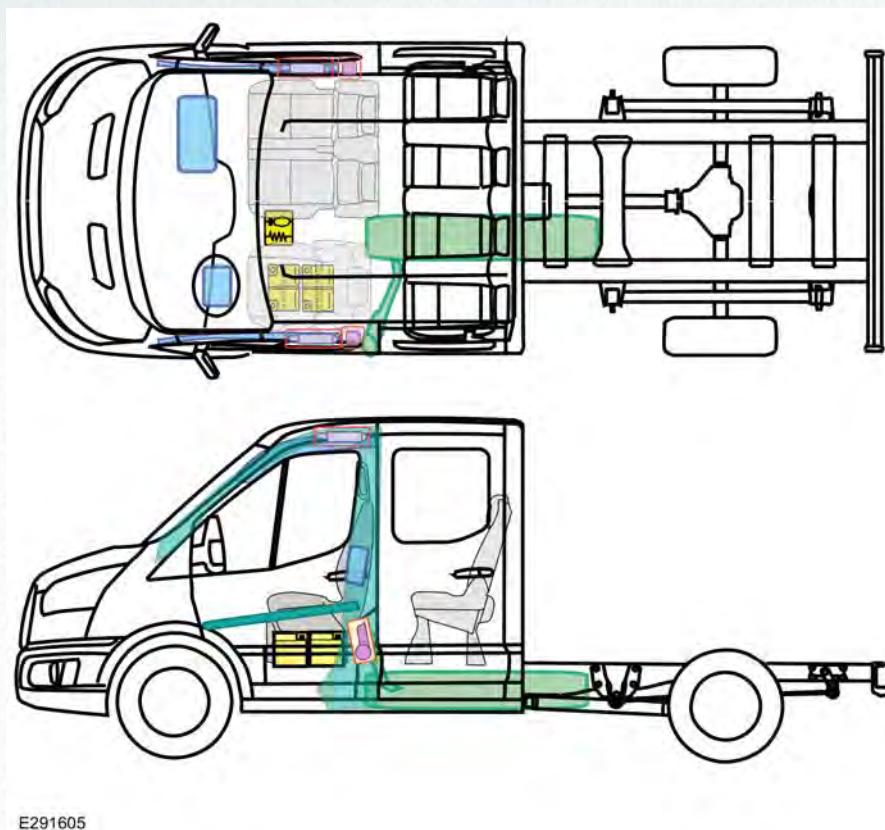

### Epígrafe

T

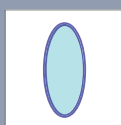

Airbag

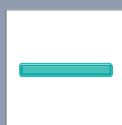

Refuerzos estructurales



Unidad de control



Sistema de protección de los peatones



Generador de gas



Protección antivuelco activa

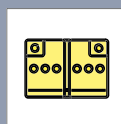

Batería

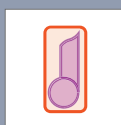

Tensor del cinturón de seguridad

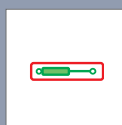

Dispositivo llenado de gas



Depósito de combustible

(Fecha De Publicacion: : 01/2019)



# FORD SERVICE

Tarjetas de rescate

## FORD Transit 2014.5

Furgoneta

08/2013 – >



E291601

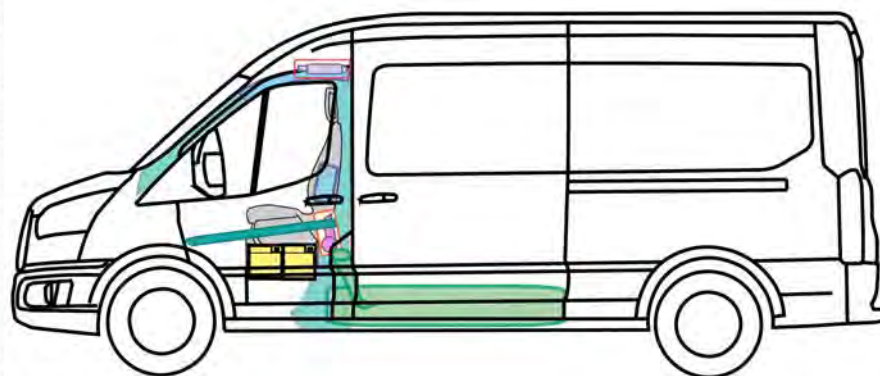
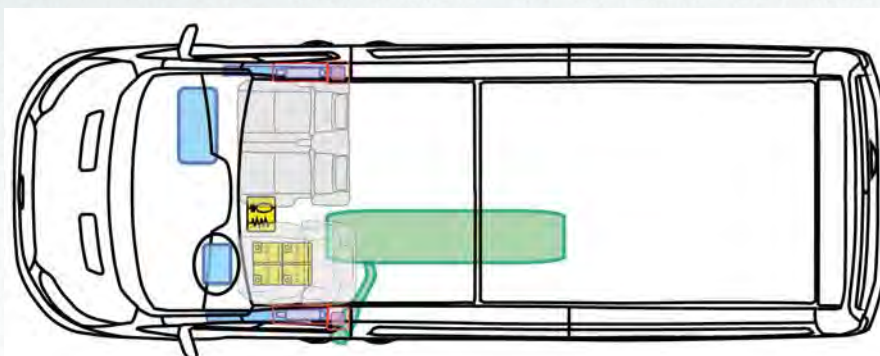

E291602

### Epígrafe

T

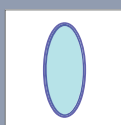

Airbag

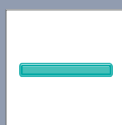

Refuerzos estructurales



Unidad de control



Sistema de protección de los peatones

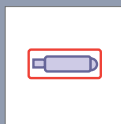

Generador de gas



Protección antivuelco activa

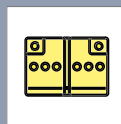

Batería

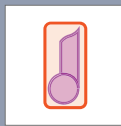

Tensor del cinturón de seguridad

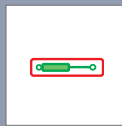

Dispositivo llenado de gas



Depósito de combustible

(Fecha De Publicacion: : 01/2019)



# FORD SERVICE

Tarjetas de rescate

## FORD Transit 2014.5

Kombi N1

08/2013 – >

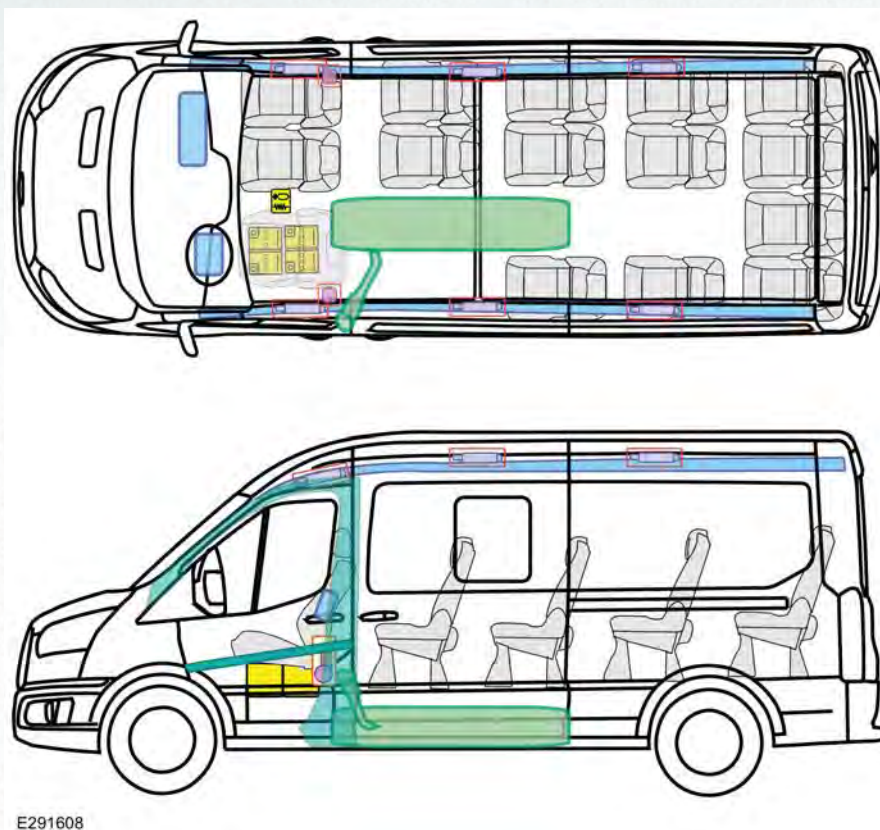

E291608

### Epígrafe

T

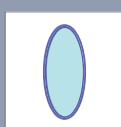

Airbag

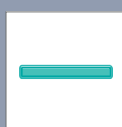

Refuerzos estructurales



Unidad de control



Sistema de protección de los peatones



Generador de gas



Protección antivuelco activa

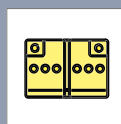

Batería

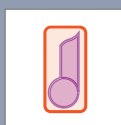

Tensor del cinturón de seguridad

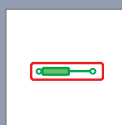

Dispositivo llenado de gas



Depósito de combustible

(Fecha De Publicacion: : 01/2019)



# FORD SERVICE

Tarjetas de rescate

## FORD Transit Connect

Furgoneta de batalla larga

02/2013 – >

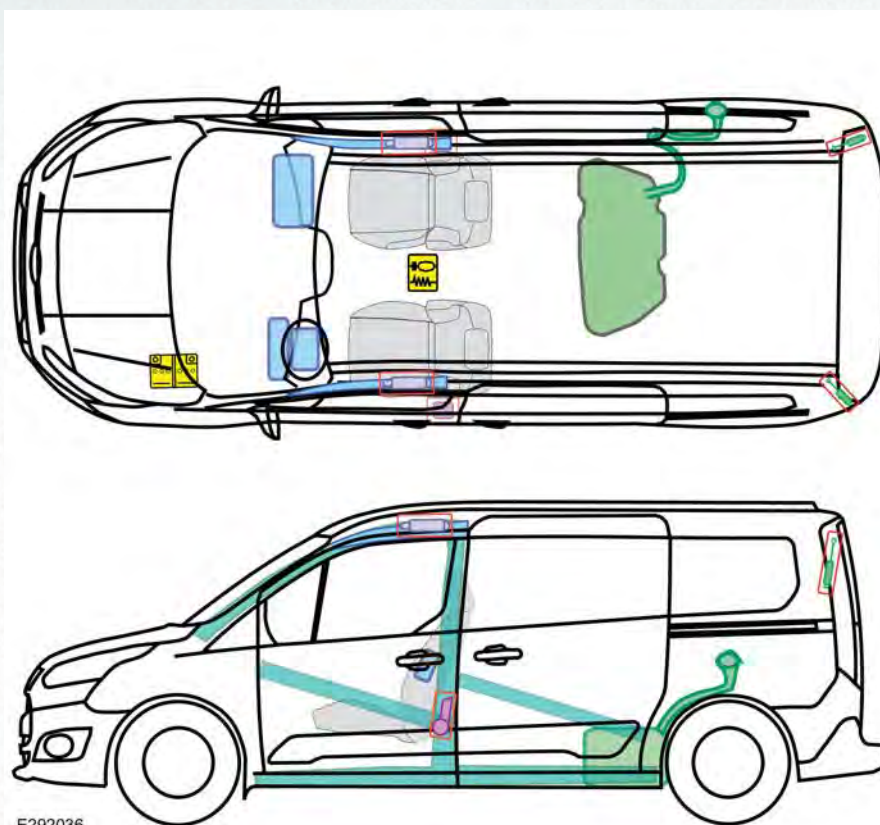

E292036

### Epígrafe

T

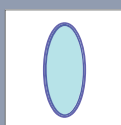

Airbag

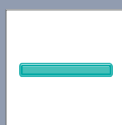

Refuerzos estructurales



Unidad de control



Sistema de protección de los peatones



Generador de gas



Protección antivuelco activa

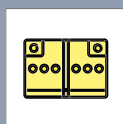

Batería

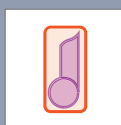

Tensor del cinturón de seguridad

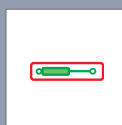

Dispositivo llenado de gas



Depósito de combustible

(Fecha De Publicacion: : 10/2018)



# FORD SERVICE

Tarjetas de rescate

## FORD Transit Courier



E303271

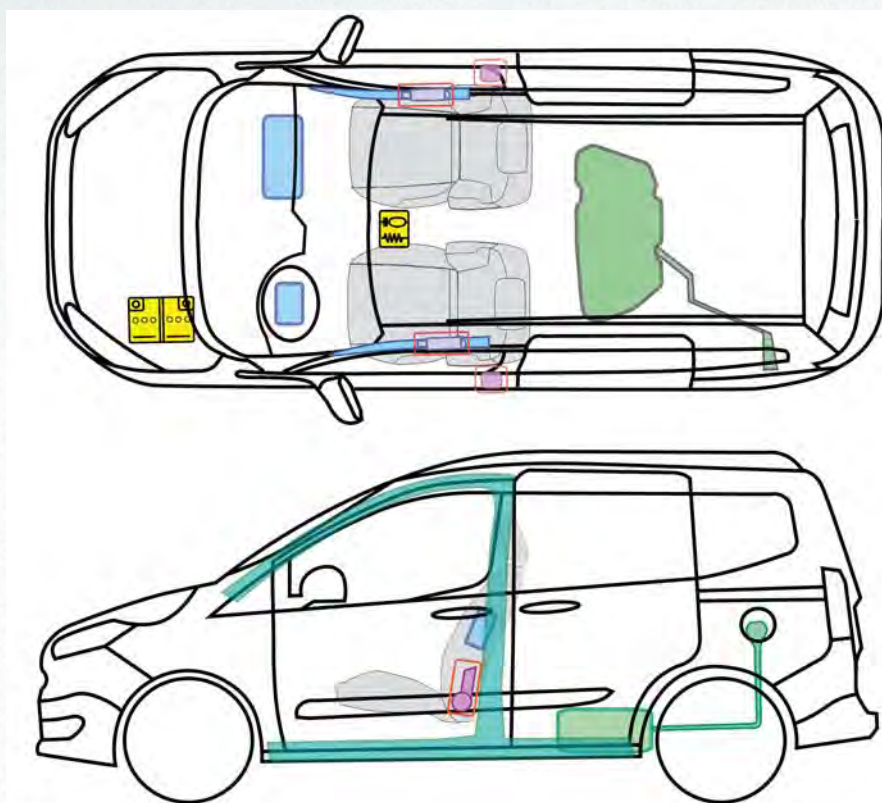

E303272

### Epígrafe

T

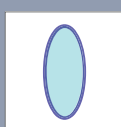

Airbag

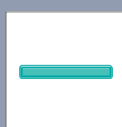

Refuerzos estructurales



Unidad de control



Sistema de protección de los peatones



Generador de gas



Protección antivuelco activa

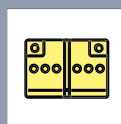

Batería

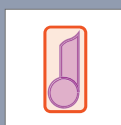

Tensor del cinturón de seguridad

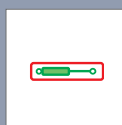

Dispositivo llenado de gas



Depósito de combustible

(Fecha De Publicacion: : 03/2019)



## FORD Transit Custom

07/2012 – >

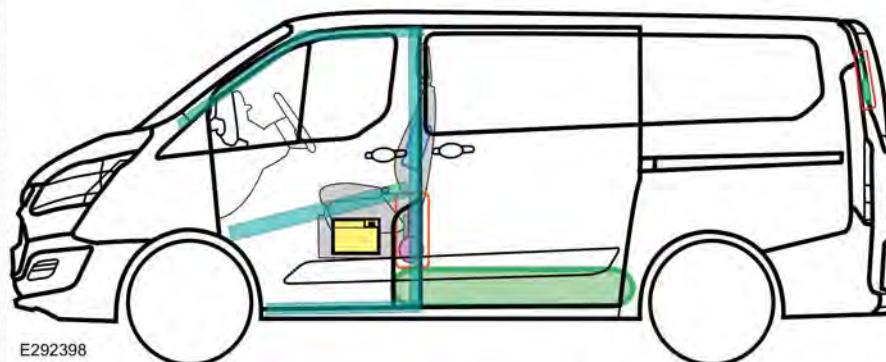
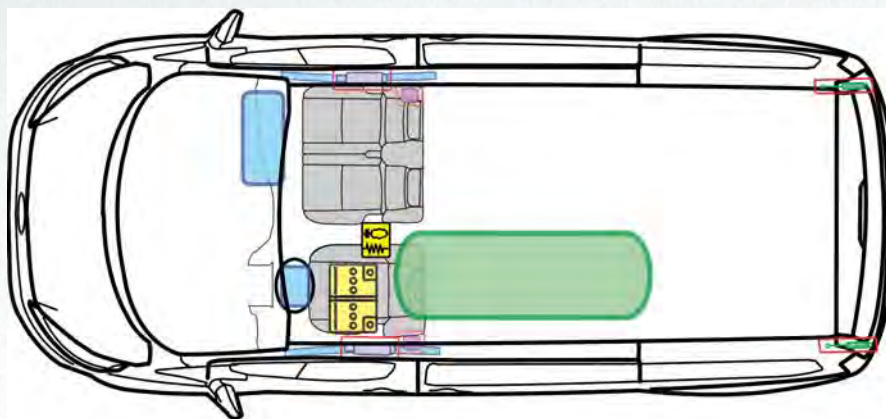

E292398

### Epígrafe

T

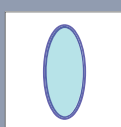

Airbag

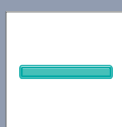

Refuerzos estructurales



Unidad de control



Sistema de protección de los peatones



Generador de gas



Protección antivuelco activa

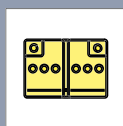

Batería

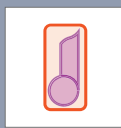

Tensor del cinturón de seguridad

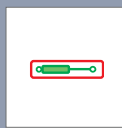

Dispositivo llenado de gas



Depósito de combustible

(Fecha De Publicacion: : 10/2018)



# FORD SERVICE

Tarjetas de rescate

## FORD Transit Custom mHEV

04/2019 – >

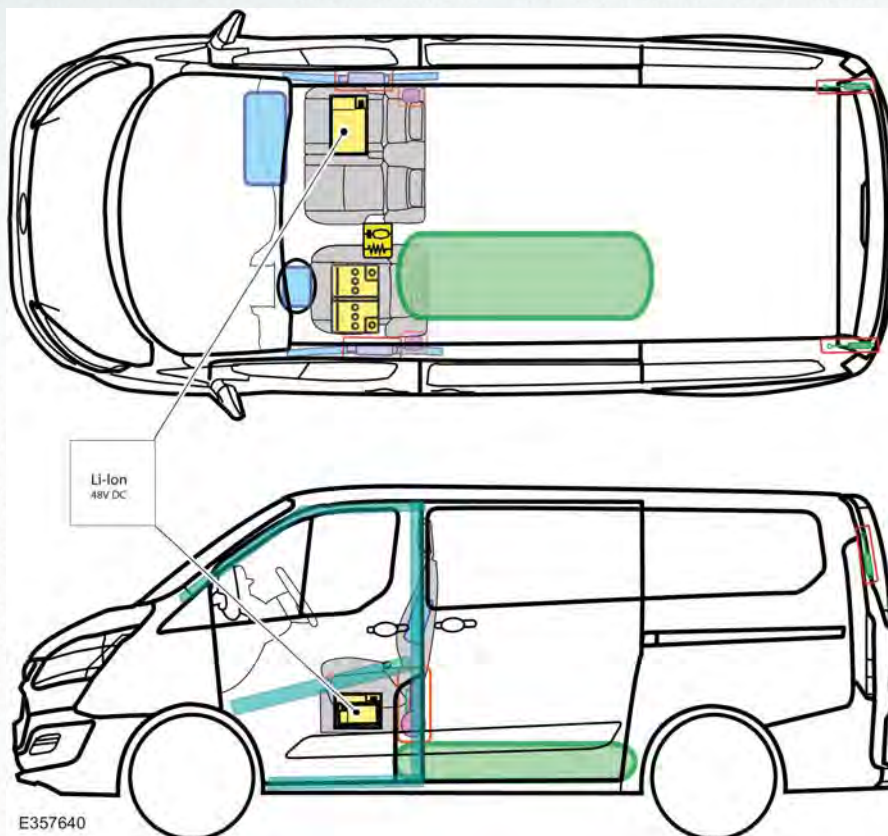

### Epígrafe

T

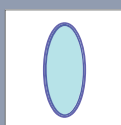

Airbag

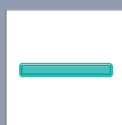

Refuerzos estructurales



Unidad de control



Sistema de protección de los peatones



Generador de gas



Protección antivuelco activa

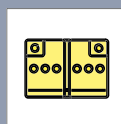

Batería

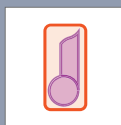

Tensor del cinturón de seguridad

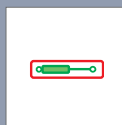

Dispositivo llenado de gas



Depósito de combustible

(Fecha De Publicacion: : 04/2021)





# FORD SERVICE

Tarjetas de rescate

## FORD Transit Custom PHEV - HEV 1,0l EcoBoost (90kW/120CV)

09/2019 – >

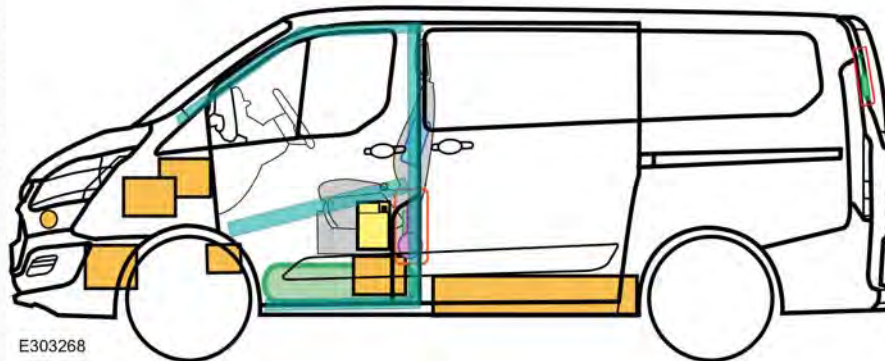
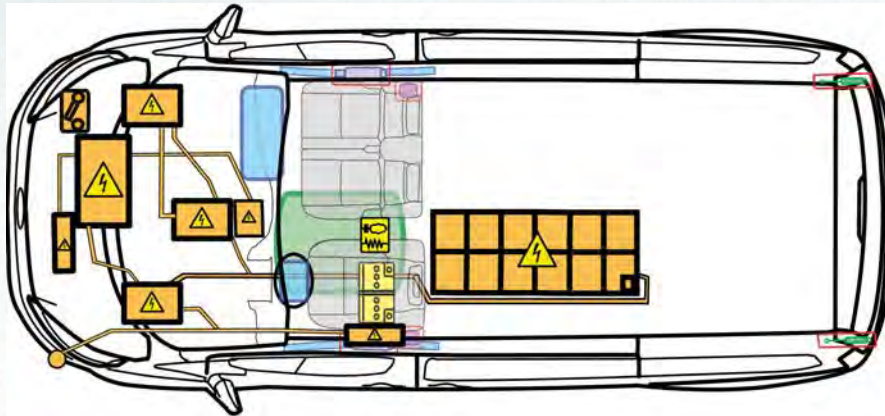

E303268

### Epígrafe

T

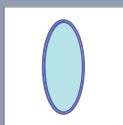

Airbag

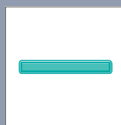

Refuerzos estructurales



Unidad de control

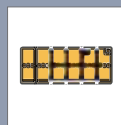

Batería de Alto Voltaje



Sistema de protección de los peatones

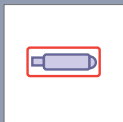

Generador de gas



Protección antivuelco activa

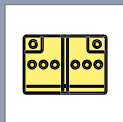

Batería

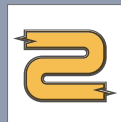

Cable de Alto Voltaje

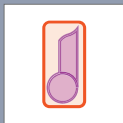

Tensor del cinturón de seguridad

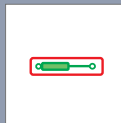

Dispositivo llenado de gas



Depósito de combustible



Punto de desconexión del Alto Voltaje

(Fecha De Publicacion: : 12/2019)



## Desactivación del sistema de alta tensión

### Introducción

**¡TENGA EN CUENTA SIEMPRE QUE EL SISTEMA DE ALTA TENSION DEL VEHICULO ESTÁ ENCENDIDO!  
ANTES DE ACCEDER AL VEHICULO, ASEGÚRESE DE QUE TODAS LAS ALIMENTACIONES ELÉCTRICAS  
EXTERNAS ESTÁN DESCONECTADAS (EJ.: CARGADOR ELÉCTRICO, HERRAMIENTAS ELÉCTRICAS).  
Si no se respetan estas advertencias, se pueden producir lesiones graves o incluso provocar la muerte.**

### IDENTIFICACIÓN DEL VEHÍCULO ELÉCTRICO

#### Identificación por el número de identificación del vehículo (VIN)

El décimo dígito del número de bastidor (VIN) identifica la línea híbrida del vehículo.

# FORD SERVICE

Tarjetas de rescate

Casillas VIN 1, 2, 3, 4, 5, 6, 7, 8, 9 y 10	VEHÍCULO
WFOMXXTTG	Transit Custom PHEV
<b>VIN de muestra</b>	
WFOMXXTTGKJ12345	

## Identificación por las características del vehículo



E306742

1. Puerto de carga de alta tensión

## FUNCIONES DE DESCONEXIÓN ELÉCTRICA DE ALTA TENSIÓN

### AVISOS:

-  Si desmonta la desconexión del servicio, se desconectará la alta tensión del vehículo. El paquete de la batería de alta tensión permanecerá activo y peligroso. No desconecte la carcasa de la batería de alta tensión. No manipule de ninguna manera el interior de las baterías de alta tensión o de la carcasa. Si es posible, aísole los componentes de alta tensión del vehículo y evite el contacto con ellos.

**⚠ Los daños en los vehículos eléctricos provocados por una colisión pueden poner en peligro los sistemas de seguridad de alta tensión y suponer un posible riesgo de descarga eléctrica de alta tensión. Extreme las precauciones y lleve siempre el equipamiento de seguridad del equipo de protección personal adecuado. Quítese todos los accesorios metálicos, incluidos reloj y anillos. Si no se respetan estas advertencias, se pueden producir lesiones graves o incluso provocar la muerte.**

**Encendido en posición de desactivado:** cuando el encendido está en posición de desactivado (y el vehículo no está cargando) el sistema de alta tensión está desactivado.

**Desconexión del servicio:** cuando las desconexiones de servicio se desmontan, el sistema de alta tensión queda desactivado.

## Desactivación del sistema de alta tensión

### Método 1

Si no es posible acceder a la batería de 12 V, pase al método 2.

1. Compruebe si el sistema de alta tensión está recibiendo alimentación.



# FORD SERVICE

Tarjetas de rescate

**2. Si el sistema de alta tensión está activo, apague el encendido.**



**3.**

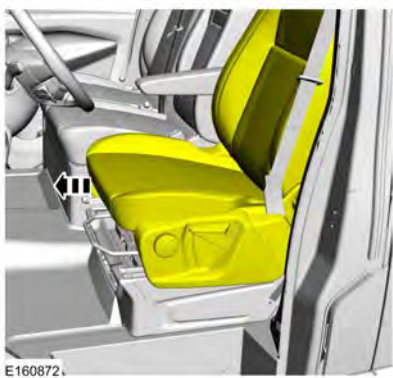

4.

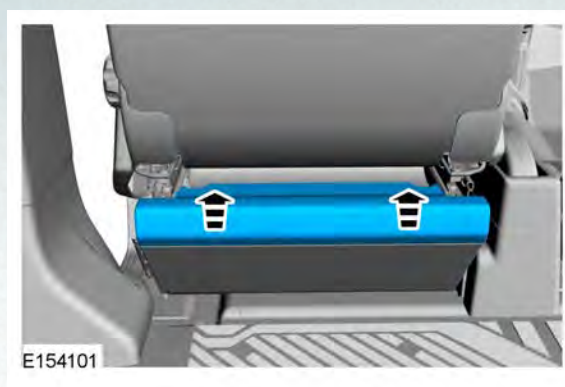

5.

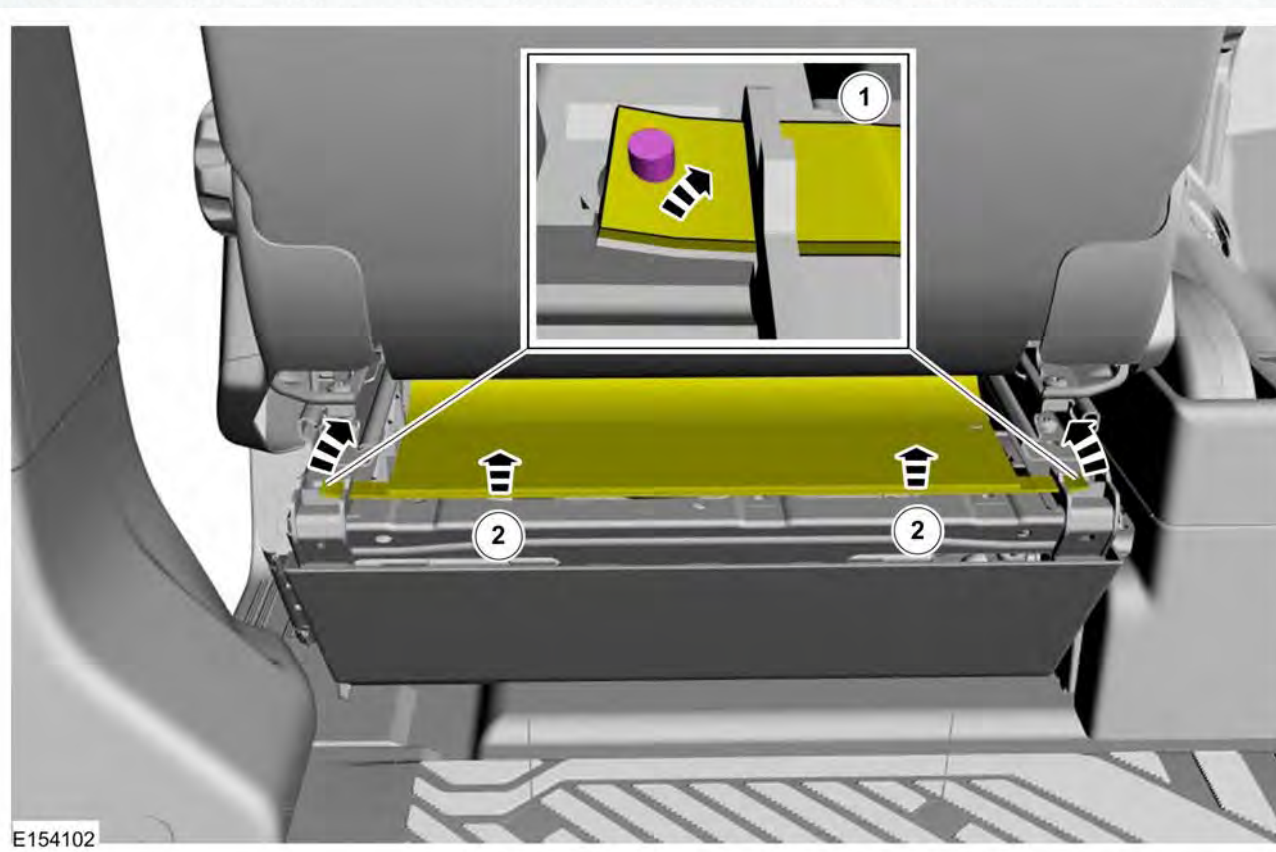

6.

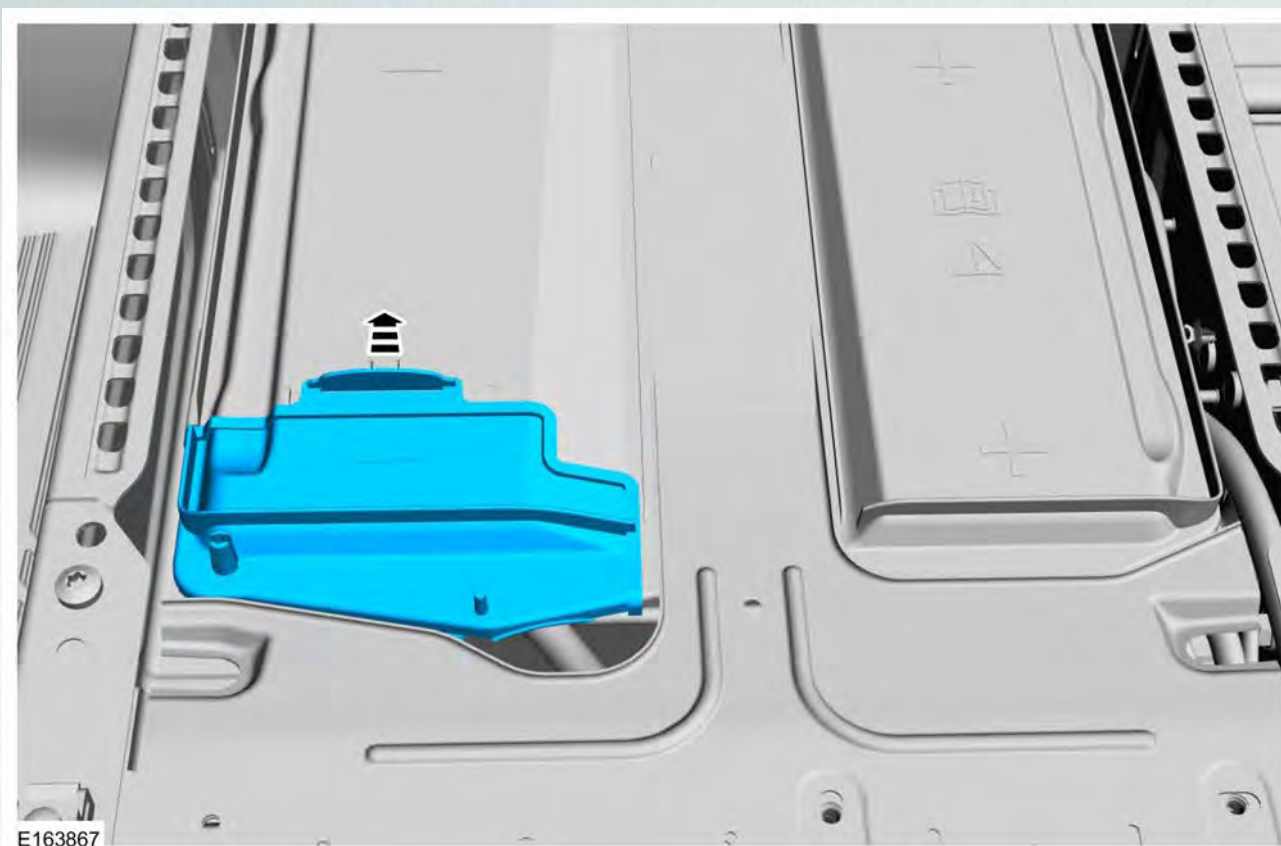

## 7. Desconecte el cable de la batería de 12 V.

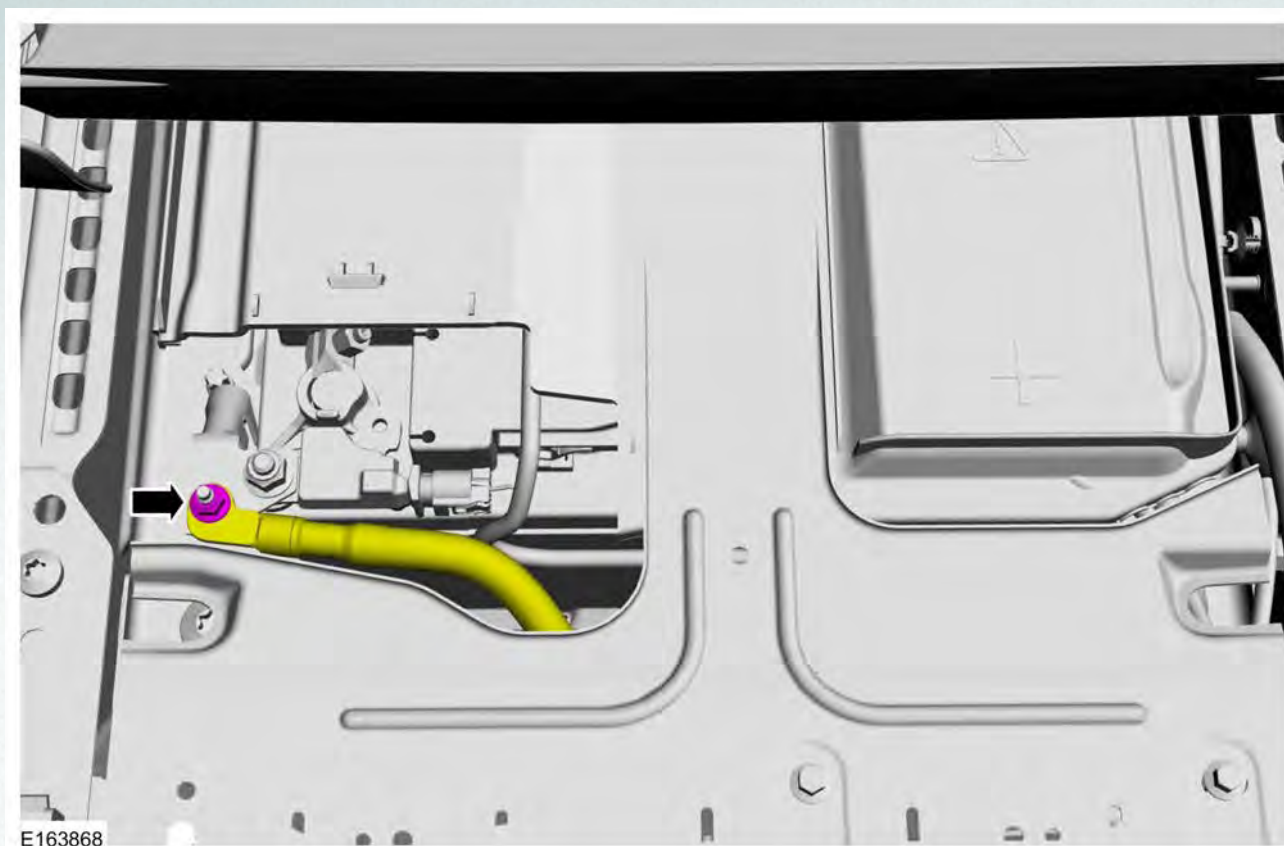



## Método 2

### 1. Abra el capó.



E307063

## 2. Ubicación de la desconexión de servicio.



E307064

**3. Para desbloquear la desconexión de servicio, abra la bloqueo rojo y desbloquee el conector pulsando el pestillo. Tire de la parte superior hacia arriba hasta que se vea la palabra "OFF". No es posible desmontar la pieza deslizante de la cabecera.**

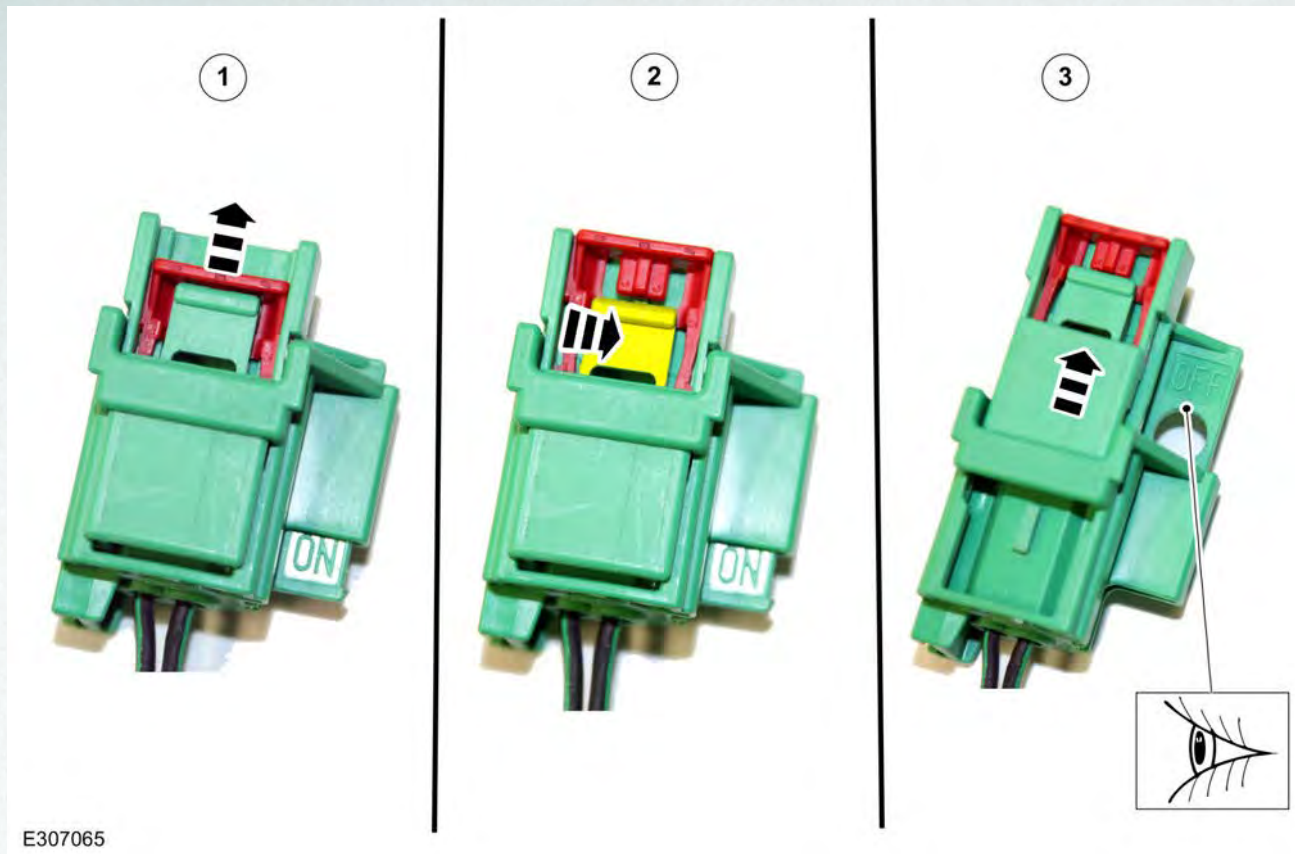

(Fecha De Publicacion: : 12/2019)

# FORD SERVICE

Tarjetas de rescate

## FORD Transit Tourneo

08/2007 - >



E139150

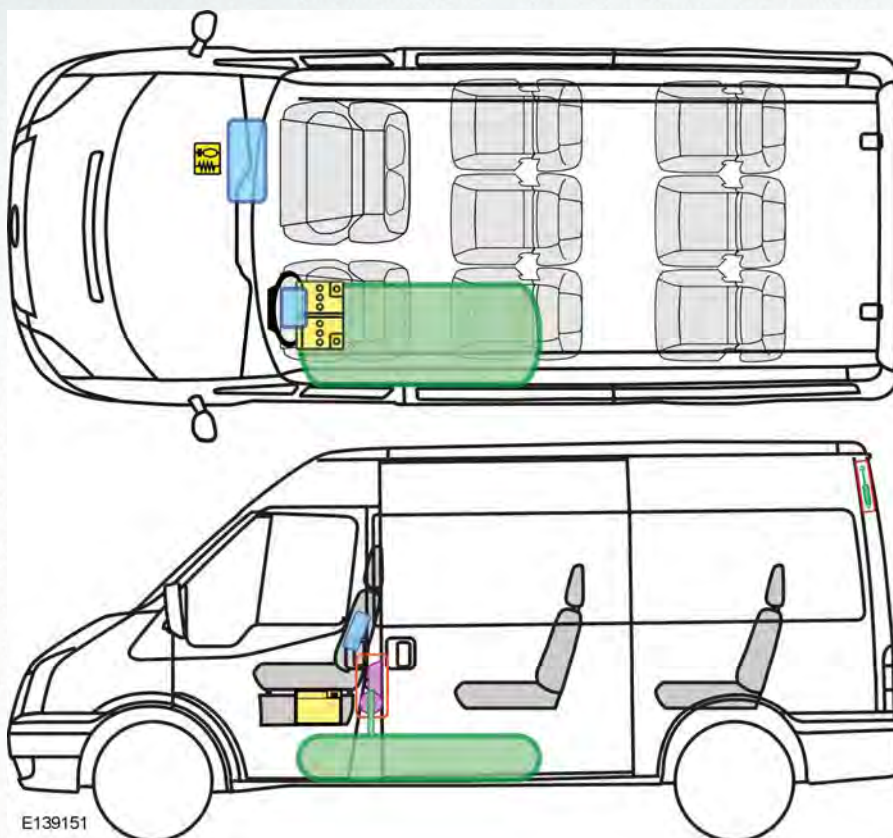

E139151

### Epígrafe

T

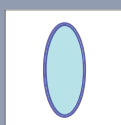

Airbag

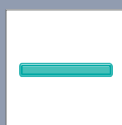

Refuerzos estructurales



Unidad de control



Sistema de protección de los peatones

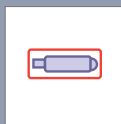

Generador de gas



Protección antivuelco activa

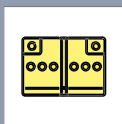

Batería

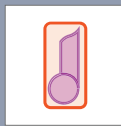

Tensor del cinturón de seguridad

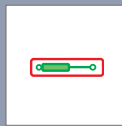

Dispositivo llenado de gas

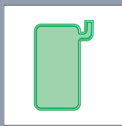

Depósito de combustible

(Fecha De Publicacion: : 03/2011)

